

# **DEEP DOWN DETECTIVES**



**Unit 12 Visual Aids**

**with**

**Simple Story Scenes, ESV**

**Volume 2**

**God's People Live for Him**



Curriculum for preschool and elementary age children,  
training tools, music and other resources  
are available for download or to order at:  
[www.praisefactory.org](http://www.praisefactory.org)

© 2023 Praise Factory Media all rights reserved. May be reproduced by licensed user for classroom purposes only.

This and many other resources are available online at [www.praisefactory.org](http://www.praisefactory.org)

Scripture quotations marked (NIV) are taken from the Holy Bible, New International Version®, NIV®, Copyright © 1973, 1978, 1984 by Biblica, Inc.™ Used by permission of Zondervan. All rights reserved worldwide.[www.zondervan.com](http://www.zondervan.com)

Scripture quotations marked (ESV) are from The Holy Bible, English Standard Version® (ESV®), copyright © 2001 by Crossway, a publishing ministry of Good News Publishers. Used by permission. All rights reserved.

Scripture quotations marked HCSB are taken from the Holman Christian Standard Bible®, Copyright © 1999, 2000, 2002, 2003, 2009 by Holman Bible Publishers. Used by permission. Holman Christian Standard Bible®, Holman CSB®, and HCSB® are federally registered trademarks of Holman Bible Publishers.

# Table of Contents

<b>About the Deep Down Detectives Visual Aids</b>	<b>5</b>
<b>Unit 12: God’s People Live for Him</b>	
<b>How Should God’s People Live? They Should Live Like Jesus!</b>	
<b>Bible Truth 5: By Learning God’s Word and Obeying It</b>	<b>7</b>
Bible Truth Overview	9
Story	11
Big Question and Answer Sign	17
Unit 12 All Bible Truths Sign	19
Bible Truth 5 Concept Sign	21
Bible Verse Sign	23
Detective Dan’s Listening Assignment #1	25
Detective Dan’s Listening Assignment #2	27
Detective Dan’s Listening Assignment #3	29
Simple Story Scenes	37
<b>Bible Truth 6: By Saying “No” to Disobeying God</b>	<b>93</b>
Bible Truth Overview	95
Story	97
Big Question and Answer Sign	103
Unit 12 All Bible Truths Sign	105
Bible Truth 6 Concept Sign	107
Bible Verse Sign	109
Detective Dan’s Listening Assignment #1	111
Detective Dan’s Listening Assignment #2	113
Detective Dan’s Listening Assignment #3	115
Simple Story Scenes	123
<b>Bible Truth 7: By Telling the Good News of Jesus</b>	<b>171</b>
Bible Truth Overview	173
Story	175
Big Question and Answer Sign	181
Unit 12 All Bible Truths Sign	183
Bible Truth 7 Concept Sign	185
Bible Verse Sign	187
Detective Dan’s Listening Assignment #1	189
Detective Dan’s Listening Assignment #2	191
Detective Dan’s Listening Assignment #3	193
Simple Story Scenes	201

## Table of Contents, continued

<b>Bible Truth 8: By Making Much of God</b>	<b>249</b>
Bible Truth Overview	251
Story	253
Big Question and Answer Sign	259
Unit 12 All Bible Truths Sign	261
Bible Truth 4 Concept Sign	263
Bible Verse Sign	265
Detective Dan's Listening Assignment #1	267
Detective Dan's Listening Assignment #2	269
Detective Dan's Listening Assignment #3	271
Simple Story Scenes	279
<b>Other Visual Aids</b>	<b>331</b>
Making a Big Question Box/Briefcase	332
Making a Flannelgraph Storyboard	333
Making Durable Storyboard Pictures	333
Making Durable Story Scene Pictures	333
Making the Deep Down Detectives Bible Folder	334
Deep Down Detectives Bible Folder Picture Front Cover	335
Deep Down Detectives Bible Folder Picture Back Cover	337

## Deep Down Detectives Curriculum Resources

There are five companion resources for each of the sixteen units of Deep Down Detectives. Use whichever resources are useful to your setting. Deep Down Detectives resources are available as free, digital downloads at [praisefactory.org](http://praisefactory.org), or for purchase as hard copies through [amazon.com](http://amazon.com).

Make sure to check out the “Bits and Pieces” section of the Deep Down Detectives curriculum online. It has all of the resources separated out making it easy for you simply to pick, choose and print out whatever you want.

### **Deep Down Detectives Core Curriculum Book, ESV/NIV for each unit**

The Deep Down Detectives Core Curriculum book contains the curriculum introduction, the lesson plans, stories, music, activities and take home sheets for each of the units.

### **Deep Down Detectives Visual Aids with Simple Story Scenes, ESV/NIV for each unit**

This resource provides large, colorful signs of the key concepts used in the unit, PLUS, easy-to-use, colorful scenes that you hold up in sequence as you tell the story. The story text for each scene is printed on the bottom of each scene.

### **Deep Down Detectives Simple Story Scenes, ESV/NIV for each volume**

This resource includes only 2-page overview for Bible Truth, the story scenes, and take home sheets. This is a great, basic resource for use at home and in many classroom teaching situations.

### **Deep Down Detectives Small Format Visual Aids, ESV/NIV (Small Format Storyboard Pictures) for each volume**

This resource provides large, colorful signs of the key concepts used in the unit, PLUS, colorful storyboard (flannelgraph) pictures to cut out and use as you tell each story. These storyboard pictures are for use with storyboards at least 24" x 36" in size.

### **Deep Down Detectives Large Format Visual Aids, ESV/NIV (Large Format Storyboard Pictures) for each volume**

This resource provides large, colorful signs of the key concepts used in the unit. It also provides colorful storyboard (flannelgraph) pictures to cut out and use as you tell each story. These storyboard pictures are for use with storyboards 36" x 48" in size.

All of these materials may be photocopied for non-commercial church, classroom or school use by licensed users.

## Other Resources in the Praise Factory Family of Curriculum

Deep Down Detectives is the second in a family of three, inter-related curriculums:

- Hide 'n' Seek Kids (focus group: ages 2-4; adaptable range: ages 2-pre-K 5's)
- Deep Down Detectives (focus group: ages 4--6's; adaptable range: ages 3-2nd grade)
- PFI: (focus group: grades K-5th grade; adaptable range: pre-K 5's-6th grade)

Each curriculum teaches the same biblical themes, but are presented in greater depth as the children grow and develop. Together, the curriculums work like an expanding spiral of truth that returns to reinforce the same truths with each curriculum, yet leading the children to deeper understanding with each step up.

Learn more about these curriculums as well as other resources and ideas for reaching children with the gospel at: [www.praisefactory.org](http://www.praisefactory.org).

## About the Deep Down Detectives Visual Aids

### How Are They Used?



The Deep Down Detectives Visual Aids book is a companion resource to be used alongside the Deep Down Detectives Core Curriculum book for each unit. These colorful pictures are used in presenting the key concepts; telling the Bible stories; and, in playing the Bible Story Review games.

### What Do They Include?



**There are four different resources included in this book:**

- 1. Key Concept Visual Aids**-- colorful signs of the Big Question and Answer, the Bible Truth, the Bible verse, and the Listening Assignments to use with the 3 lessons for each Bible Truth.
- 2. The Story Scenes.** Notice that each scene is numbered and that there is a brief summary of the story that corresponds to the picture. You can actually just tell the story in a simple way by using only the text at the bottom of each Story Scene.
- 3. Directions** for making the Deep Down Detectives "Bible" Folder and the **back/front images** to paste in place when making it. (Larger back/front images are found online with the curriculum.)
- 4. Directions** for how to make a homemade flannelgraph storyboard and sturdy Story Scene pictures are found in the back of this book.

### Ready, Set, Rip It Out!

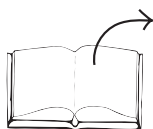

This book is meant to be ripped up and made into your visual aids. The key concept signs can be cut out and laminated or slipped into sheet protectors. The Story Scenes can be put in sheet protectors or laminated, too.

### Store It!



Deep Down Detectives is a curriculum that can be used over and over. Store your visual aids and storyboard pictures after using them and they will serve you for many years. We store ours in manilla envelopes and then put them (along with all the rest of the curriculum) in magazine files, labelled by Bible Truth. If you have multiple classes using the curriculum, store each set of resources in separate manilla envelopes. This will make prep much simpler, second time around.

### Replacement Story Scene Pictures



You can always purchase this book again or simply go online and print out any scenes that go missing.

### Other Options



You can also choose to tell the story in a more traditional flannelgraph way by using your own flannelgraph figures or by purchasing/free downloading the Storyboard Pictures (large and small format size available). This is more complex and requires more preparation, but some love it. And, it does allow for kids to interact more by helping to place pictures up on the board as you tell the story.

# **DEEP DOWN DETECTIVES**



**Visual Aids**

**Unit 12,**

**Bible Truth 5**

## About the Deep Down Detectives Visual Aids

### How Are They Used?



The Deep Down Detectives Visual Aids book is a companion resource to be used alongside the Deep Down Detectives Core Curriculum book for each unit. These colorful pictures are used in presenting the key concepts; telling the Bible stories; and, in playing the Bible Story Review games.

### What Do They Include?



**There are four different resources included in this book:**

- 1. Key Concept Visual Aids**-- colorful signs of the Big Question and Answer, the Bible Truth, the Bible verse, and the Listening Assignments to use with the 3 lessons for each Bible Truth.
- 2. The Story Scenes.** Notice that each scene is numbered and that there is a brief summary of the story that corresponds to the picture. You can actually just tell the story in a simple way by using only the text at the bottom of each Story Scene.
- 3. Directions** for making the Deep Down Detectives "Bible" Folder and the **back/front images** to paste in place when making it. (Larger back/front images are found online with the curriculum.)
- 4. Directions** for how to make a homemade flannelgraph storyboard and sturdy Story Scene pictures are found in the back of this book.

### Ready, Set, Rip It Out!

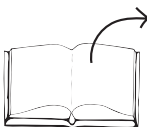

This book is meant to be ripped up and made into your visual aids. The key concept signs can be cut out and laminated or slipped into sheet protectors. The Story Scenes can be put in sheet protectors or laminated, too.

### Store It!



Deep Down Detectives is a curriculum that can be used over and over. Store your visual aids and storyboard pictures after using them and they will serve you for many years. We store ours in manilla envelopes and then put them (along with all the rest of the curriculum) in magazine files, labelled by Bible Truth. If you have multiple classes using the curriculum, store each set of resources in separate manilla envelopes. This will make prep much simpler, second time around.

### Replacement Story Scene Pictures



You can always purchase this book again or simply go online and print out any scenes that go missing.

### Other Options



You can also choose to tell the story in a more traditional flannelgraph way by using your own flannelgraph figures or by purchasing/free downloading the Storyboard Pictures (large and small format size available). This is more complex and requires more preparation, but some love it. And, it does allow for kids to interact more by helping to place pictures up on the board as you tell the story.



**Unit 12: God's People Live for Him**

**Unit Big Question (and Answer):** How Should God's People Live? They Should Live Like Jesus!

**Unit Bible Verse:** "Be imitators of God, as beloved children. And walk in love, as Christ loved us and gave himself up for us." --Ephesians 5:1-2, ESV

**Bible Truth 5 Concept: They Should Live Like Jesus... By Learning God's Word and Obeying It!**

Jesus knew God's Word and obeyed it His whole life. There was nothing about God's Word that Jesus did not know or obey. It was very important that Jesus knew God's Word so well and that He always obeyed it. This was the only way He could be the perfect Savior who could pay for the sins of God's people.

God's Word helped Jesus know how He should live. It gave Him strength to fight temptation and to keep on obeying God, His Father, no matter what. And, when life was hard or sad, it comforted Him with God's good plans and promises.

God's people need to know God's Word well, too. It tells them about God and His good plans. It tells them how He wants them to live. It gives them strength to fight temptation and keep on obeying God, no matter what. And, when life was hard or sad, it comforts them with God's good plans and promises.

How do God's people learn God's Word? By reading it, memorizing it, singing it, and by others teaching it to them. God promises that His Holy Spirit will work in the hearts of His people as they hear His Word. He will help them understand it and obey it. We can become God's people when we turn away from our sins and trust in Jesus as our Savior. He will help us to know and obey His Word, too.

**Bible Truth 5 Bible Verse: Psalm 119:11,15,16 ESV**

"I have stored up your word in my heart, that I might not sin against you. I will meditate on your precepts and fix my eyes on your ways. I will delight in your statutes; I will not forget your word."

**Learn a Little:** "I have stored up your word in my heart, that I might not sin against you."

**Meaning**

God's people delight in God's Word, the Bible. It is full of God's precepts and decrees (His good laws). It tells of His ways (what God is like). They meditate on God's Word (think about what it means); and, even hide it in their hearts (memorize it) so that they might not sin against God. They know that God's Word is not just true. It is also powerful to change them to be more like Jesus. They don't want to neglect it, because they want to know God and please Him more than anything else in life. God can help us delight in His Word, too.

**Bible Truth 5 ACTS Prayer**

- A** God, we praise You for being the Giver of Your Word, the Bible. Through it, we see how amazing You are.
- C** God, please forgive us for not loving Your Word as we should. Too many times we choose to not read Your Word but do other things instead. Too many times, even when we do read Your Word, we forget it and do not obey it. We need a Savior!
- T** Thank You, God, for telling us so much about Yourself and Your great plans through the Bible. Thank You for telling us about Jesus and how we can be saved when we read it. Thank You for showing us how to live and promising to help us through Your powerful Word.
- S** God, please work in our hearts. Help us turn away from our sins and trust in Jesus as our Savior. Help us to love Your Word, the Bible. Send Your Holy Spirit to help us understand it and obey it. Help us to live like You want us to live. In Jesus' name we pray, Amen.

**Bible Truth 5 Story**

**The Case of the Lost Treasure** *2 Kings 22; 23:1-20; 24; 2 Chronicles 34:8-33*

**Songs Used in Bible Truth 5**

Big Q & A 12 Song

Big Question 12 Song: How Should God's People Live?

Big Question 12 Bible Verse Song: Walk in Love *Ephesians 5:1-2, ESV*

*Extra Big Question 12 Bible Verse Song: Let Everyone Who Names the Name 2 Timothy 2:19,22, ESV*

Big Question 12 Hymn: Trust and Obey, v.1

Big Question 12 Praise Song: I Have Decided to Follow Jesus

Bible Truth 5 Bible Verse Song: I Have Stored Up Your Word *Psalm 119:11,15-16, ESV*

*Extra Bible Truth 5 Bible Verse Song: If Anyone Loves Me John 14:23, ESV*

*Extra Bible Truth 5 Bible Verse Song: Jesus Answered John 14:23-24, ESV*

*Extra Bible Truth 5 Bible Verse Song: For We Are God's Workmanship Ephesians 2:10; 6:7-8, NIV 1984*

*listen to or download songs for free at <https://praisefactory.org>: Deep Down Detectives Music page*

**The Case of the Lost Treasure***2 Kings 22; 23:1-20; 24; 2 Chronicles 34:8-33***Story-telling Tips**

Ahead of time:

1. Read the Bible verses and story. Pray!
2. Choose story action cues and prepare storyboard figures/story scenes, if using. (In Visual Aids book)
3. Practice telling story with the storyboard pictures, timing your presentation. Shorten, if necessary.

During your presentation:

1. Maintain as much eye contact as possible as you tell the story.
2. Put up storyboard figures/add story action cues/hold up storybook scenes as you tell the story. Allow the children to help you put them on the board, if desired.
3. Include the children in your story with a few questions about what they think will happen or words/concepts that might be new to them.
4. Watch the kids for signs that their attention span has been reached. Shorten, if necessary.

**INTRODUCTION/ LISTENING ASSIGNMENTS**

**"Our story is called: The Case of the Lost Treasure. Here is your listening assignment."** Read from Detective Dan's Listening Assignment signs, but questions are summarized below:

**Detective Dan's Lesson #1 Listening Assignment:**

I need to find out:

1. **What was the treasure? And why was it hidden?**
2. **Who found it and what did they do with it?**

**Detective Dan's Lesson #2 Listening Assignment:****Our Bible Verse is Psalm 119:11,15,16, ESV**

"I have stored up your word in my heart, that I might not sin against you. I will meditate on your precepts and fix my eyes on your ways. I will delight in your statutes; I will not forget your word."

I need to find out:

1. **Who was supposed to hide God's Word in their hearts by writing down their very own copy of it?**
2. **What happened when they did this? What happened when they did not?**

**Detective Dan's Lesson #3 Listening Assignment:**

I found six clues, but only 4 of them are in the story.

They are: a bee, a scroll, a fake god, a cake, King Amon, and a big, covenant promise.

*Hold each of them up for the children to see as you identify them.*

I need to figure out:

1. **Which four belong in the story and which two don't?**
2. **Who asked God to forgive them for hiding away God's word? Did God forgive them?**

**Read the assignment questions, THEN SAY,**

"Ok, Deep Down Detectives! Put on your best listening ears and see if you can hear the answers to Detective Dan's questions. When I finish telling the story, we will see if we can answer all the questions."

*Read the Bible Truth story, answer questions, present the gospel and lead in prayer.*

*Answers to questions; the gospel; and, ACTS prayer are included with the story text.*

**The Case of the Lost Treasure** *2 Kings 22; 23:1-20; 24; 2 Chronicles 34:8-33*

*Story with lines separating paragraphs (text in bold, optional interaction cues in italics)*

Moses was a very old man. For many years, the LORD had used him to lead the people of Israel. Moses led them out of slavery in Egypt, then up to great Mt. Sinai to meet with the LORD. There, they made big, covenant promises. The LORD promised to always be their God, who would care for them. And the people promised to always be His people, who would love Him and keep His good laws. For forty, long years, Moses led the people through the dry, desert-y wilderness. Finally, came the wonderful day they were waiting for: the day when Moses brought them to the edge of the Promised Land. It was time to enter the good land the LORD promised to give them as their home.

Moses had been a good leader. He had written down God's Word. He had taught the people to obey the LORD and His good laws. But now, Moses' work was done. It was time for him to die and to go heaven to live with the LORD forever. So, he gathered the people together to teach them one last time.

"Love the LORD with all your heart, all your mind, and all your strength. Keep on learning God's laws. Know them and obey them!" Moses urged the people of Israel. "If you do, God will keep you as His special people. He will protect you. He will use everything you go through to do good in your lives and to show everyone how great He is," Moses promised them.

"And make sure your kings know God's laws, too," Moses warned them. "Each king should write down their own copy of God's Word. Every, single word! This will help them know and obey God. This will help them be good kings for you," Moses told the people.

Moses knew there was nothing like God's Word. It is powerful and good. It is always true. It tells us how to live. It helps us know and love God. And God promises to bless those who obey it. God's Word is a treasure. A precious treasure! Moses wanted to make sure the people understood this.

The people of Israel listened to Moses and said, "We will do everything you say. We will learn God's laws and obey them. We will tell our kings to write them down and obey them, too," they promised.

But DID the people of Israel keep their promise? DID they learn God's Word and obey it? DID they have their kings write it down and obey it, too?

*What do you think?*

Well, sometimes they did; but many times, they didn't. They acted as if it didn't matter if they or their kings learned and obeyed God's Word.

But it DID matter, as the people of Israel found out over and over. For whenever they learned and obeyed God's Word, they grew closer to the LORD. They worshipped Him and lived for Him. And the LORD blessed them with good things, their whole lives.

The LORD also used His Word to make their kings good kings. When they copied it down as the LORD told them to, He taught them His good ways and helped them live them out. They took good care of the people, and the LORD protected their land from all their enemies. Life was so good when the people and their kings learned and obeyed God's Word! The LORD blessed them in so many ways!

*Story with lines separating paragraphs (text in bold, optional interaction cues in italics)*

**But how very different life was when the people and their kings STOPPED learning God's Word and obeying it. The people did not grow closer to Him. They stopped obeying God's good laws, too. They hurt each other and broke their promises to the LORD.**

**The kings stopped copying down God's Word and reading it. Without the LORD and His Word, they stopped being good kings. No longer did they take good care of the people. No longer did their enemies stay away. What sad times came upon them, just as the LORD said would happen!**

**Some of these kings even brought in the fake gods of their enemies and worshipped them instead. They ordered the people to worship these fake gods and give their worship gifts to them. They let the Temple fall apart. They didn't care about the LORD.**

---

**And what happened to God's Word when the kings and the people turned away from the LORD and His good ways?**

*Can you guess?*

**They got rid of it! They threw it away like useless trash, instead of treating it like the treasure it was. Oh, what terrible things the people and their kings had done! And oh, what terrible punishment they deserved for breaking their promises to God!**

**This is how things were when Josiah became king. Josiah's father, Amon, had been one of the bad kings. He worshipped fake gods, and gave his worship gifts to them, instead of the LORD. He ordered the people to worship these fake gods, too. He forgot about God's Word and let it be lost. What a terrible king he was!**

---

**But Josiah was very different from his father. While he was still just a little boy, he began to seek after the LORD. He turned away from those fake gods and turned to the LORD. And when he became king, he led the people in turning back to the LORD, too. "Get rid of these fake gods," Josiah commanded his workers. "Worship the LORD," Josiah told the people. "Give your worship gifts to Him, the one true God," Josiah said.**

**To the Temple, went the king's workers. Out went all the fake gods. "Smash, crash, crumble," the workers broke them into pieces and ground them into powder. No one would worship them again!**

---

**Then, "Bang, whack, thump," up went new wood and new stone as they fixed up the broken places in the Temple. The beautiful, golden things used to worship the LORD were brought out again. They were cleaned up and made ready. The tables, the plates, the candlesticks, the altar, the wash basin... everything! The workers worked and worked. What a lot there was to clean up and fix!**

---

**And as they worked, they found a book, forgotten and hidden away.**

*Can you guess what book they found?*

**It was God's Word, the Bible!**

*Story with lines separating paragraphs (text in bold, optional interaction cues in italics)*

**Hilkiah, the Temple leader, brought God's Word to Shaphan, King Josiah's helper. "I have found God's Word in the Temple. Take it."**

**Shaphan took it and read it. Then, HE took it to King Josiah and read it to HIM. King Josiah listened to every word. For the first time, Josiah heard how LORD created the world. He heard how the LORD had rescued the people from Pharaoh in Egypt and given them His good laws at Mt. Sinai. He heard about the big, covenant promises He made with the people of Israel to always be their God. What wonderful stories these were! This book had been hidden away and forgotten. It had been treated like trash. But Josiah could see that this book was a treasure, more precious than gold. How happy he was to hear God's Word!**

**As King Josiah kept listening, his happiness turned to worry. Yes, the LORD had made big, covenant promises with the people of Israel to be their God; but, THEY had made promises with the LORD, too. They had promised to worship Him and obey His good laws, but they had NOT done that. Nor had they learned God's Word or obeyed it as they had promised. The kings had NOT written God's Word and learned it either. No! They had all forgotten the LORD and broken His good laws. Now, they all deserved the LORD's punishment. Uh, oh!**

**King Josiah was so upset that he stood up and tore his clothes. (That's what they used to do long ago when they were very, very upset—but we shouldn't do it!) "Oh, no! What should we do?" said King Josiah. "We deserve God's terrible punishment for breaking our promises to Him!" he exclaimed.**

**The LORD gave Josiah His answer through the prophetess Huldah. "Yes, you deserve My punishment for breaking your promise to keep My laws, but I am a God of mercy," the LORD said. "Since you want to learn my Word and obey it, I will not punish the people as they deserve. And when I do finally punish them, I will use that punishment to bring them back to love and obey Me," He promised.**

**King Josiah was so happy! He would learn God's Word and obey it. He would teach the people of Israel to obey it, too. He was so glad that the LORD would keep them as His people!**

**So at last, when the Temple was all repaired, King Josiah gathered all the people together in front of it. Then he, himself, read out loud to them. Can you guess what he read?**

*Can you guess?*

**He read God's Word to them. Every single word of it!**

**As the people heard God's Word, God worked in their hearts. He helped them be sorry for their sins. He helped them turn back to Him and His good laws.**

**Then all together, King Josiah and the people prayed to the LORD, "We promise to worship You. We promise to learn Your Word and obey it." And so they did, all the days that Josiah was their king.**

**Cracking the Case:** (story wrap-up for Listening Assignments)

It's time to see how we did with our Listening Assignment.

**Detective Dan's Lesson 1 Listening Assignment:****1. What was the treasure? And why was it hidden?**

It was a book: the Bible, God's Word. It was hidden because King Amon and the people didn't care about it. They put it in a room and forgot about it until it was lost.

**2. Who found it and what did they do with it?** King Josiah's workers found it. They gave it to the king to read. He asked God for forgiveness and helped the people obey it again.

**For You and Me:**

God's Word is filled with good things for God's people, who lived long ago. But it is filled with good things for us, too. God's Word can teach us. From it, we can learn about God and how He wants us to live. He can use it to help us turn away from our sins and put our trust in Jesus as our Savior. It can be a great treasure that God uses to bless us every day of our lives.

**Detective Dan's Lesson 2 Listening Assignment:****Our Bible Verse is Psalm 119:11,15,16 ESV:**

"I have stored up your word in my heart, that I might not sin against you. I will meditate on your precepts and fix my eyes on your ways. I will delight in your statutes; I will not forget your word."

**1. Who was supposed to hide God's Word in their hearts by writing down their very own copy of it?**

**Why?** The kings so they would know God's Word and lead the people in loving and obeying God.

**2. What happened when they did this? What happened when they did not?** God helped them to love Him. He helped them obey it. He blessed the people. But, when they didn't, they turned away from loving God and obeying His Word. The people suffered.

**For You and Me:**

God didn't just want people long ago to know His Word and obey it from their hearts. He wants us to, also. God loves to work in our hearts as we learn His Word. He loves to use it to help us turn away from our sins and trust in Jesus as our Savior. He loves to use it to help us know Him and to live for Him. Ask Him to use His Word to work in your heart! He loves to answer this prayer.

**Detective Dan's Lesson 3 Listening Assignment:**

Our six clues were: a bee, a scroll, a fake god, a cake, King Amon, and a big, covenant promise.

**1. Which four belong in our story?** The scroll, the fake god, King Amon, and the big covenant promise belong.

**2. Who asked God to forgive them for hiding away God's word? Did God forgive them?** King Josiah and the people asked for God's forgiveness. God was merciful and forgave them. He promised to only discipline them to help bring them back to live like His people again.

**For You and Me:**

Like the people of Israel, we, too, forget God's Word. We choose to disobey it. We choose to do things our own way. But, we, too, can come to God and ask for His forgiveness. We can ask Him to use His Word to work in our hearts and help us trust in Jesus as our Savior. We can ask Him to help us to love His Word and obey it. God loves to answer these prayers! Ask Him to help you!

The Bible can teach us these things, too. We, too, can become God's people when we turn away from disobeying God and trust Jesus as our Savior. We can learn from it how to love God and live to please Him more and more with the help of His powerful Holy Spirit.

**The Gospel** (story wrap-up if NOT using Listening Assignments)**Our Bible Truth is:****How Should God's People Live?****They Should Live Like Jesus...****By Learning God's Word and Obeying It!**

How should God's people live each day? They should live like Jesus... by learning God's Word and obeying it! God's people love the Bible! The Bible is how they learned they were sinners who deserved God's punishment. The Bible is how they learned about God's great mercy in sending Jesus to be our Savior. And through the Bible, they know God will teach them more and more about how to love Him and how to live to please Him.

The Bible can teach us these things, too. We, too, can become God's people when we turn away from disobeying God and trust Jesus as our Savior. We can learn from it how to love God and live to please Him more and more with the help of His powerful Holy Spirit.

*Close in prayer.*

**Closing ACTS Prayer**

- A** God, we praise You for being the Giver of Your Word, the Bible. You are amazing!
- C** God, please forgive us for not loving Your Word as we should. Too many times we choose to not read Your Word but do other things instead. Too many times, even when we do read Your Word, we forget it and do not obey it. We need a Savior!
- T** Thank You, God, for telling us so much about Yourself and Your great plans through the Bible. Thank You for telling us about Jesus and how we can be saved when we read it. Thank You for showing us how to live and promising to help us through Your powerful Word.
- S** God, please work in our hearts. Help us turn away from our sins and trust in Jesus as our Savior. Help us to love Your Word, the Bible. Send Your Holy Spirit to help us understand it and obey it. Help us to live like You want us to live. In Jesus' name we pray, Amen.

***Go to Lesson Plan, p.9 for the script to the rest of the lesson.***



# How should God's people live?

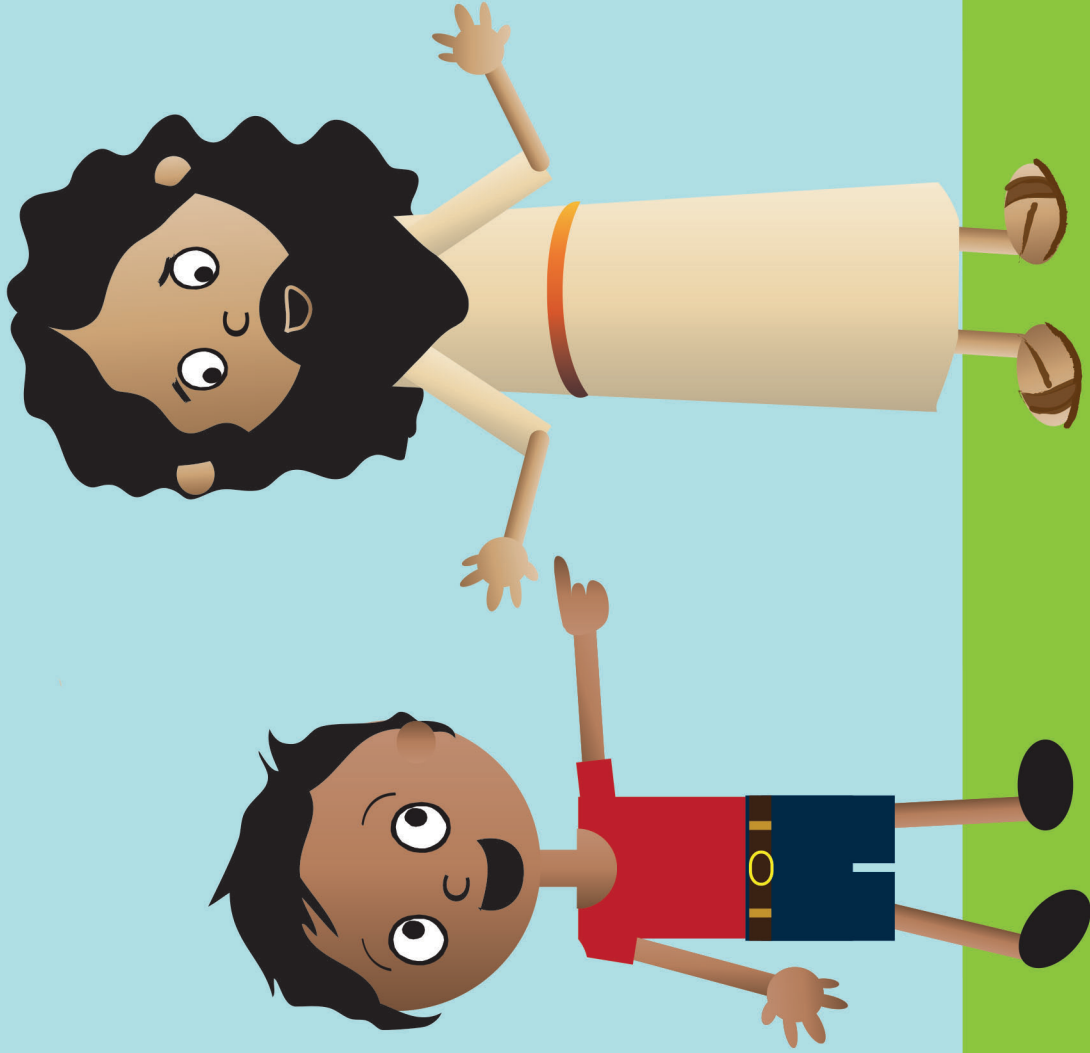

ANSWER:

# They should live like Jesus!

VISUAL  
AID  
**#1**  
take out  
BIG  
QUESTION  
of BQB

## The Big Question

*Hold up the Big Question sign for all the children to see, and say:*

The Big Question we are investigating today is Big Question

Number 12:

**How Should God's People Live?**

and the Answer is:

**They Should Live Like Jesus!**

### **Meaning:**

We become God's people when we turn away from our sins and trust in Jesus as our Savior. When we do, God forgives our sins, and we begin a whole new way of life. God's people no longer live life just to please themselves. They want to honor God with their whole lives, like Jesus did. They seek to love God most of all and love all people, too.

Let's sing our Big Question Song: "

## Big Q & A 12 Song

*DDD ESV Songs 12, track 12*

*(adapted version of "Pop, Goes the Weasel")*

How should God's people live each day?

They should live like Jesus!

How should God's people live each day?

How should God's people live each day?

How should God's people live each day?

They should live like Jesus!

# BIG QUESTION 12: Eight truths about how God's people live

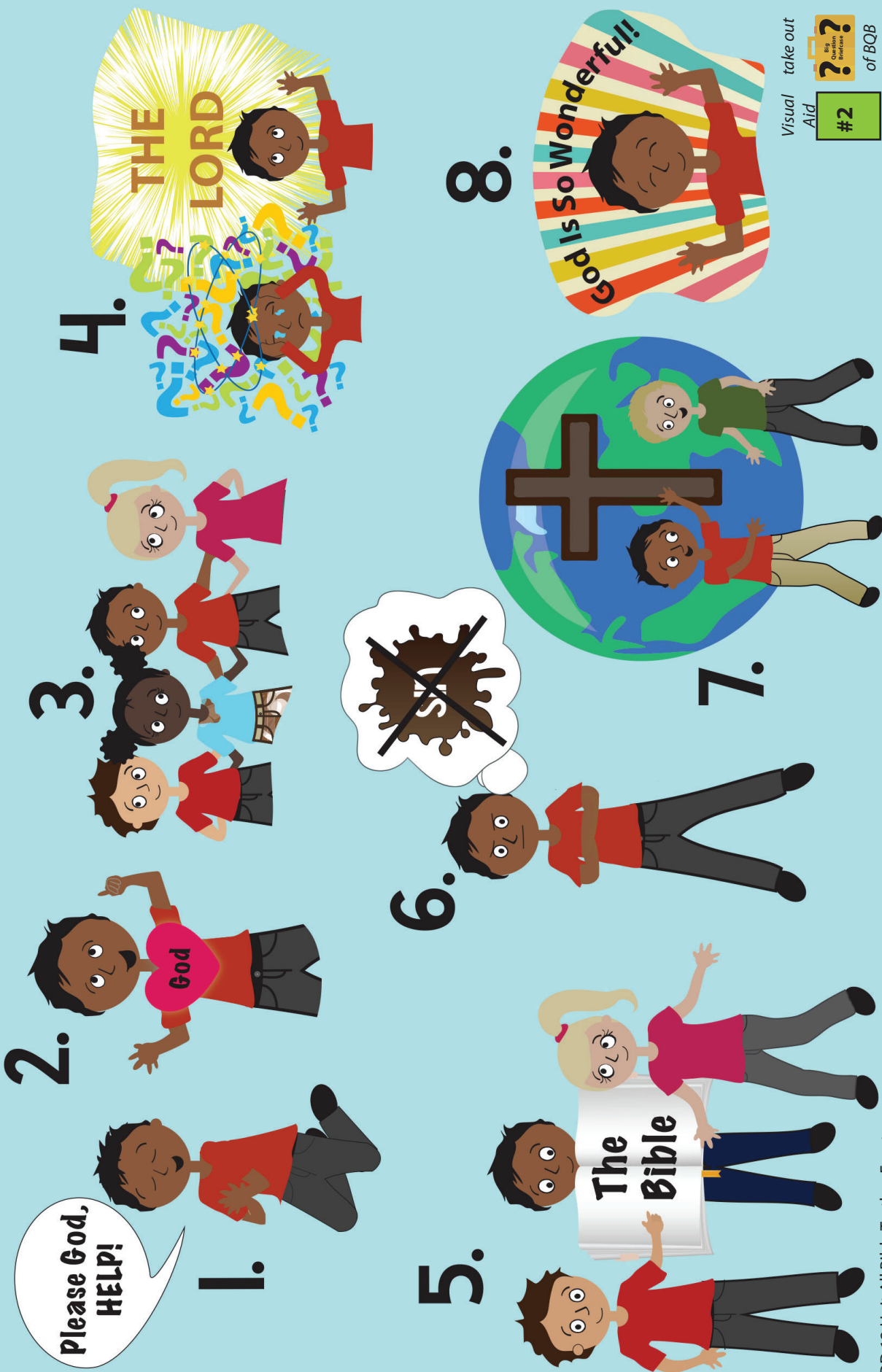

Visual take out  
Aid #2  
The Question Briefcase  
of BQB

## **This Unit's Bible Truths**

"They Should Live Like Jesus" is a good beginning, but there's so more to learn. So it's time for us to dig down even deeper for more answers to our Big Question about God. We're going to be learning EIGHT Bible truths that all tell us more about how God wants His people to live.

Who would like to hand me the picture with our eight Bible truths on it? It's in the Big Question Box/Briefcase."

*Choose a child to get it and hand it to you, then hold it up and show them the pictures of the eight truths they will be learning.*

*After everyone has had a good look say...*

"Ok, we've learned four truths about how to live for God. They are: "By Asking God for His Help," "By Loving God Most of All," "By Loving Other People as God Has Loved Them, and, "By Trusting God and Being Happy with What He Wants." (point to pictures as you identify each Bible Truth). Now let's look at our Bible Truth Clue sign and see if we can figure out which of these eight truths we will be learning about today. Who would like to get it out of the Big Question Briefcase for me?"

*Choose a child to open the briefcase, take out the Bible Truth Clue sign and hand it to you.*

CAN YOU GUESS BIBLE TRUTH 5?

**How Should God's People Live?  
They Should Live  
Like Jesus...**

**By Learning God's Word  
and ???!!**

**HINT:** This word means doing  
what someone tells you to do.  
It starts with an "O" and  
it rhymes with "okaying."

**ANSWER:  
By Learning God's Word  
and OBEYING!!**



# Revealing the Bible Truth We Are Learning

*Hold up the front side for the children to see. Cover up the answer, written along the bottom, and say:*

**“How Should God’s People Live?  
They Should Live Like Jesus!  
By Learning God’s Word and ???? It!”**

We’re missing one word. Here’s the hint to what the missing word is. It says: “This word means doing what someone tells you to do. It starts with an “O” and it rhymes with “okaying.”

Can you guess? It’s “OBEYING.”

So, the Bible Truth we are learning today is:

*(uncover answer from bottom of sign, show it to them and say:)*

**“How Should God’s People Live?  
They Should Live Like Jesus!  
By Learning God’s Word and OBEYING It!”**

And here is what this Bible Truth means:

*(read the meaning off of the back of the sign, say:)*

Jesus knew God’s Word and obeyed it His whole life. There was nothing about God’s Word that Jesus did not know or obey. It was very important that Jesus knew God’s Word so well and that He always obeyed it. This was the only way He could be the perfect Savior who could pay for the sins of God’s people.

God’s Word helped Jesus know how He should live. It gave Him strength to fight temptation and to keep on obeying God, His Father, no matter what. And, when life was hard or sad, it comforted Him with God’s good plans and promises.

God’s people need to know God’s Word well, too. It tells them about God and His good plans. It tells them how He wants them to live. It gives them strength to fight temptation and keep on obeying God, no matter what. And, when life was hard or sad, it comforts them with God’s good plans and promises.

How do God’s people learn God’s Word? By reading it, memorizing it, singing it, and by others teaching it to them. God promises that His Holy Spirit will work in the hearts of His people as they hear His Word. He will help them understand it and obey it. We can become God’s people when we turn away from our sins and trust in Jesus as our Savior. He will help us to know and obey His Word, too.

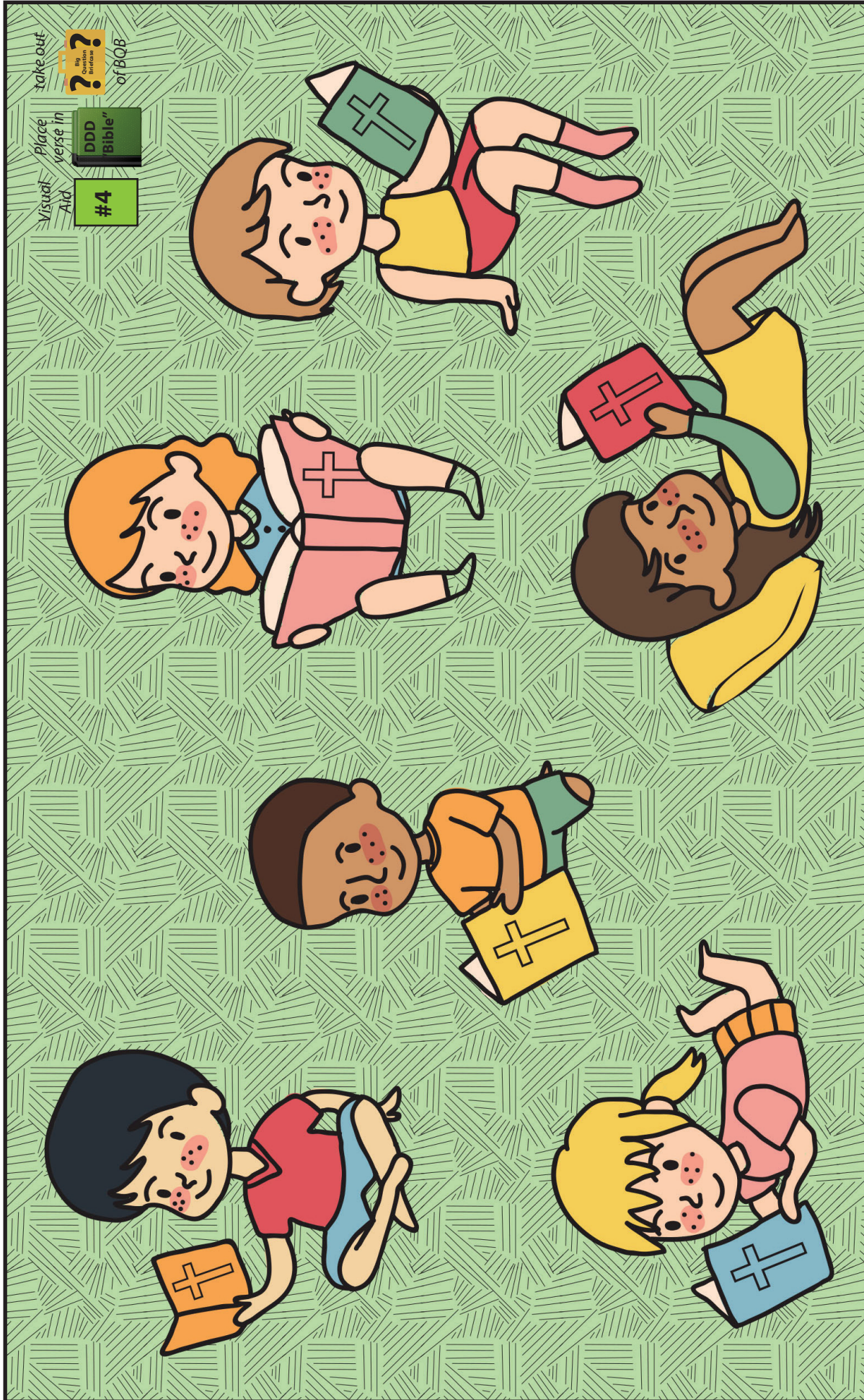

**"I have stored up your word in my heart, that I might not sin against you.**

**I will meditate on your precepts and fix my eyes on your ways.**

**I will delight in your statutes; I will not forget your word." -- Psalm 119:11,15,16**

## Bible Truth 5 Bible Verse

*Remove the Bible Verse Picture from the "Bible" folder and hold it up for all the children to see, then say:*

Psalm 119:1,15,16 tells us:

### **Psalm 119:11,15,16:**

"I have stored up your word in my heart, that I might not sin against you. I will meditate on your precepts and fix my eyes on your ways. I will delight in your statutes; I will not forget your word."

### **Learn a Little:**

"I have stored up your word in my heart, that I might not sin against you."

### **What does that mean?**

God's people delight in God's Word, the Bible. It is full of God's precepts and decrees (His good laws). It tells of His ways (what God is like). They meditate on God's Word (think about what it means); and, even hide it in their hearts (memorize it) so that they might not sin against God. They know that God's Word is not just true. It is also powerful to change them to be more like Jesus. They don't want to neglect it, because they want to know God and please Him more than anything else in life. God can help us delight in His Word, too.

"Now it's time to do a bit more deep down investigating. Let's see what Detective Dan wants us to help him figure out. Would someone like to get it out for me?"

"We've said our Bible verse, now let's sing it!"

"We've said our Bible verse, now let's sing it!"

## I Have Stored Up Your Word:

### **Psalm 119:11,15,16**

*DDD ESV Songs 12, track 34*

I have stored up your word in my heart,  
That I might not sin against you,  
I have hidden your word in my heart,  
That I might not sin against you.

I'll meditate on your precepts,  
And fix my eyes on your ways.  
I'll delight in your statutes,  
I will not forget your word,

I have stored up your word in my heart,  
That I might not sin against you,  
I have hidden your word in my heart,  
That I might not sin against you.  
Psalm One-nineteen, eleven through sixteen.

"Now it's time to do a bit more deep down investigating. Let's see what Detective Dan wants us to help him figure out. Would someone like to get it out for me?"



take out



Place in



Visual Aid



# Detective Dan's Listening Assignment #1

# Detective Dan's

## Listening Assignment #1



Hi, Deep Down Detectives!

I'm working on a brand-new case called:

"The Case of the Lost Treasure."

I need to find out:

1. What was the treasure? And why was it hidden?
- AND
2. Who found it and what did they do with it?

Can you help me? Listen carefully to the story and you might just hear the answers!

Thanks!

Detective Dan

***Then say,*** "Ok, Deep Down Detectives! Put on your best listening ears and see if you can hear the answers to Detective Dan's questions. When I finish telling the story, we will see if we can answer all of his questions."

*Read the Bible Truth story, putting up the storyboard pictures as you tell it.*

*At the end of the story, repeat the questions and lead the children in answering them. Present the gospel and close in prayer.*

\*Answers to assignment questions, the gospel and ACTS prayer are also included at the end of the story text.\*

Answers:

**1. What was the treasure? And why was it hidden?** It was a book: the Bible, God's Word. It was hidden because King Amon and the people didn't care about it. They put it in a room and forgot about it until it was lost.

**2. Who found it and what did they do with it?** King Josiah's workers found it. They gave it to the king to read. He asked God for forgiveness and helped the people obey it again.

**For You and Me:**

God's Word is filled with good things for God's people, who lived long ago. But it is filled with good things for us, too. God's Word can teach us. From it, we can learn about God and how He wants us to live. He can use it to help us turn away from our sins and put our trust in Jesus as our Savior. It can be a great treasure that God uses to bless us every day of our lives.

take out



of BQB

Place in



Visual Aid



# Detective Dan's Listening Assignment #2

# Detective Dan's

## Listening Assignment #2



Hi, Deep Down Detectives!

I'm still working on the case called:

"The Case of the Lost Treasure."

Our Bible verse is Psalms 119:1,15,16, ESV

"I have stored up your word in my heart, that I might not sin against you. I will meditate on your precepts and fix my eyes on your ways. I will delight in your statutes; I will not forget your word."

I need to find out:

1. Who was supposed to hide God's Word in their hearts by writing down their very own copy of it?

AND

2. What happened when they did this? What happened when they did not?

Can you help me? Listen carefully to the story and you might just hear the answers!

Thanks for your help!

Detective Dan

**Then say,** "Ok, Deep Down Detectives! Put on your best listening ears and see if you can hear the answers to Detective Dan's questions. When I finish telling the story, we will see if we can answer all of his questions!"

*Read the Bible Truth story, putting up the storyboard pictures as you tell it. At the end of the story, repeat the questions and lead the children in answering them. Present the gospel and close in prayer.*

\*Answers to assignment questions, the gospel and ACTS prayer are also included at the end of the story text.\*

Answers:

**Our Bible Verse is Psalm 119:1,15,16, ESV**

"I have stored up your word in my heart, that I might not sin against you. I will meditate on your precepts and fix my eyes on your ways. I will delight in your statutes; I will not forget your word."

**1. Who was supposed to hide God's Word in their hearts by writing down their very own copy of it? Why?** The kings so they would know God's Word and lead the people in loving and obeying God.

**2. What happened when they did this? What happened when they did not?** God helped them to love Him. He helped them obey it. He blessed the people. But, when they didn't, they turned away from loving God and obeying His Word. The people suffered.

**For You and Me:**

God didn't just want people long ago to know His Word and obey it from their hearts. He wants us to, also. God loves to work in our hearts as we learn His Word. He loves to use it to help us turn away from our sins and trust in Jesus as our Savior. He loves to use it to help us know Him and to live for Him. Ask Him to use His Word to work in your heart! He loves to answer this prayer.

take out



Place in



Visual Aid



# Detective Dan's Listening Assignment #3

# Detective Dan's

## Listening Assignment #3



Hi, Deep Down Detectives!

I'm still working on the case called:

"The Case of the Lost Treasure."

I found SIX clues, but TWO of them are NOT in the story. They are: a bee, a scroll, a fake god, a cake, King Amon, and a big, covenant promise.

*Hold up each of the six pictures for the children to see as you identify them. Better yet, put them up on your flannelgraph board, off to one side.*

I need to know:

1. Which FOUR pictures belong in the story and which TWO do NOT?
2. Who asked God to forgive them for hiding away God's word? Did God forgive them?

Can you help me? Listen carefully to the story and you might just hear the answers!

Thanks!

Detective Dan

**Then say,** "Ok, Deep Down Detectives! Put on your best listening ears and see if you can hear the answers to Detective Dan's questions. When I finish telling the story, we will see if we can answer all of his questions."

*Read the Bible Truth story, putting up the storyboard pictures as you tell it. At the end of the story, repeat the questions and lead the children in answering them. Present the gospel and close in prayer.*

\*Answers to assignment questions, the gospel and ACTS prayer are also included at the end of the story text.\*

Answers:

1. Which four pictures belong in the story and which two do not?  
1. The scroll, the fake god, King Amon and the big, covenant promise belong. The bee and the cake do not.
2. Who asked God to forgive them for hiding away God's word? Did God forgive them? King Josiah and the people asked for God's forgiveness. God was merciful and forgave them. He promised to only discipline them to help bring them back to live like His people again.

**For You and Me:**

Like the people of Israel, we, too, forget God's Word. We choose to disobey it. We choose to do things our own way. But, we, too, can come to God and ask for His forgiveness. We can ask Him to use His Word to work in our hearts and help us trust in Jesus as our Savior. We can ask Him to help us to love His Word and obey it. God loves to answer these prayers! Ask Him to help you!

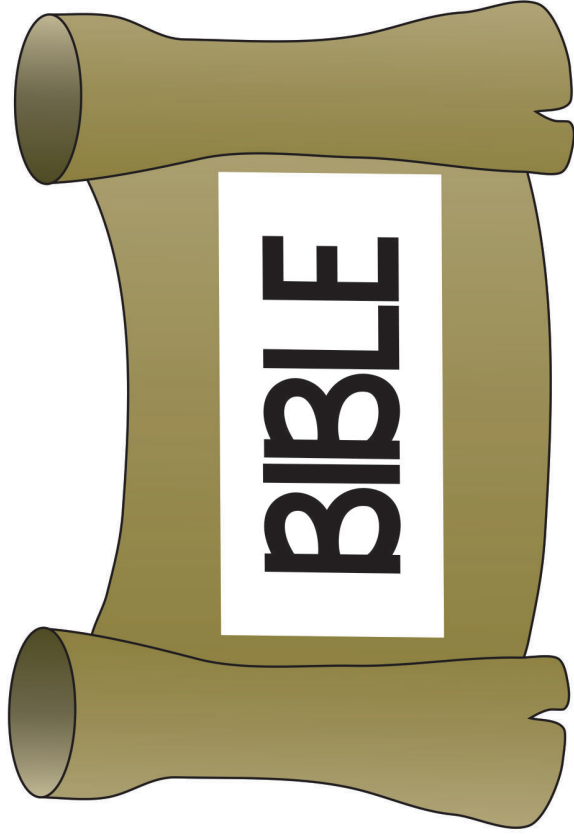

A Scroll



A Bee

VISUAL  
AID  
#5C

Place in  
DDD  
Bible™

take out  
Big  
Question  
Bible™  
of BQB

DDD 12.5 Lesson 3 Listening Assignment Clue Picture 2 for kids

VISUAL  
AID  
#5C

Place in  
DDD  
Bible™

take out  
Big  
Question  
Bible™  
of BQB

DDD 12.5 Lesson 3 Listening Assignment Clue Picture 1 for kids



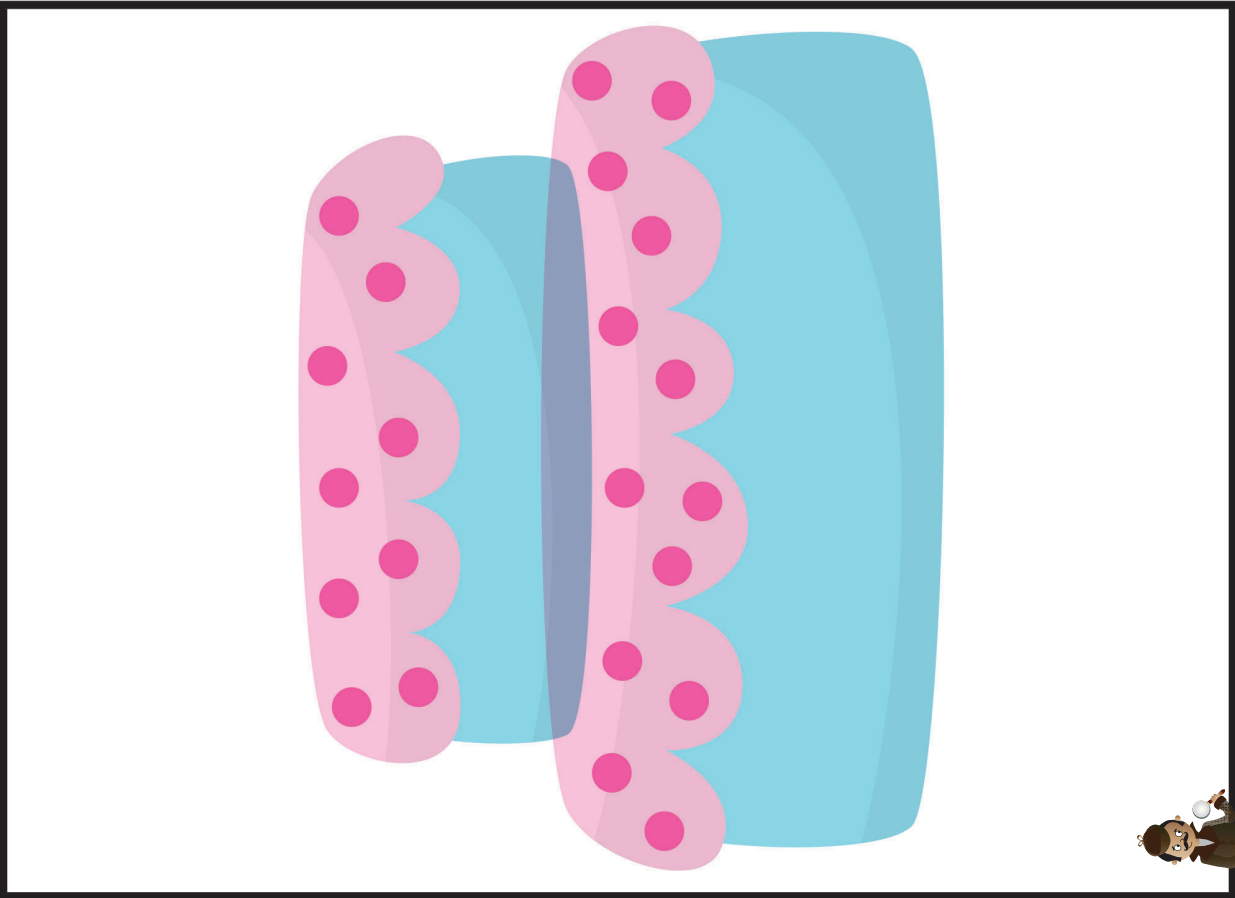

A Cake

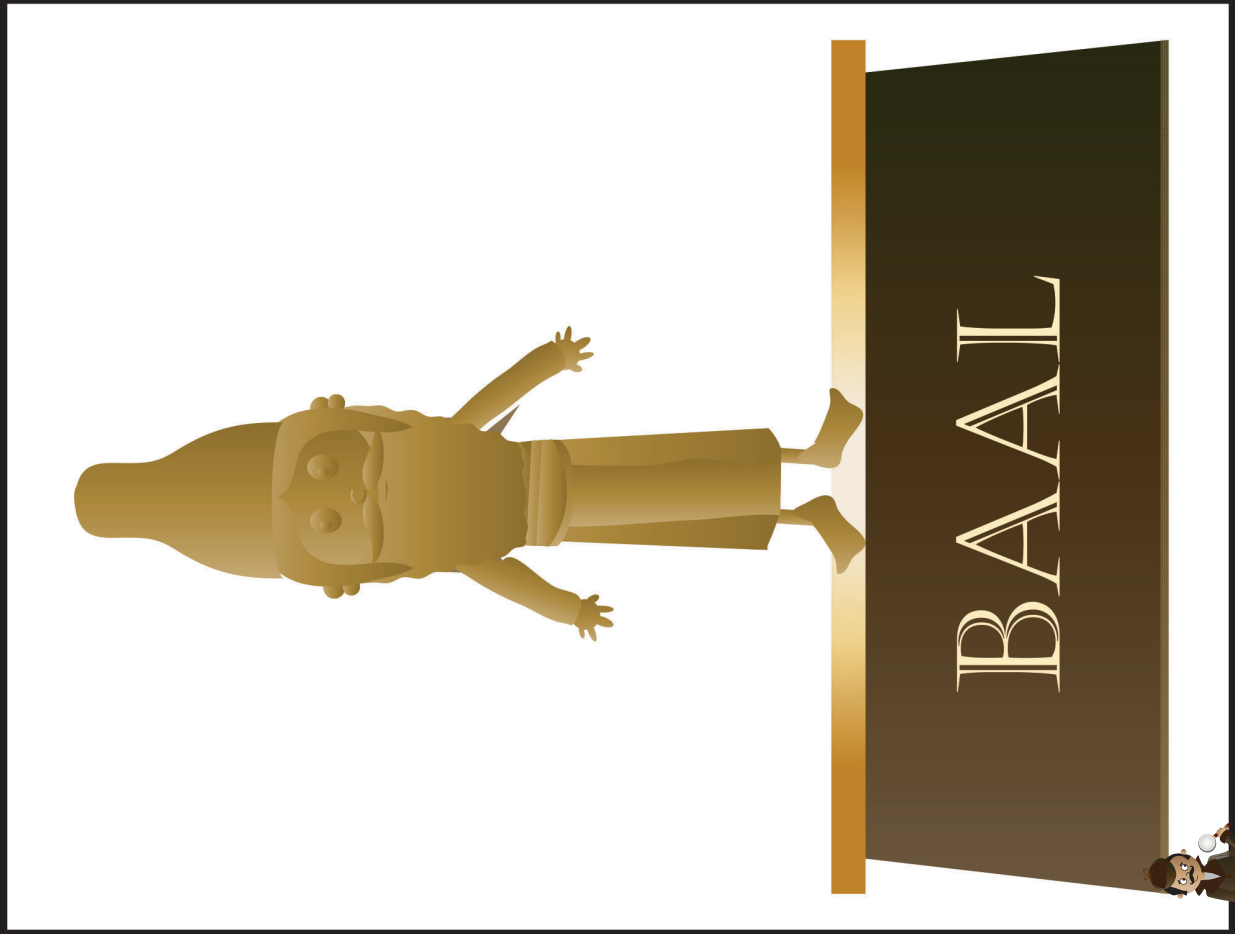

A Fake God

VISUAL  
AID  
#5C

Place in  
DDD  
Bible™

take out  
Big  
Question  
Briefcase  
of BQB

VISUAL  
AID  
#5C

Place in  
DDD  
Bible™

take out  
Big  
Question  
Briefcase  
of BQB

DDD 12.5 Lesson 3 Listening Assignment Clue Picture 4 for kids

DDD 12.5 Lesson 3 Listening Assignment Clue Picture 3 for kids



A Big, Covenant Promise

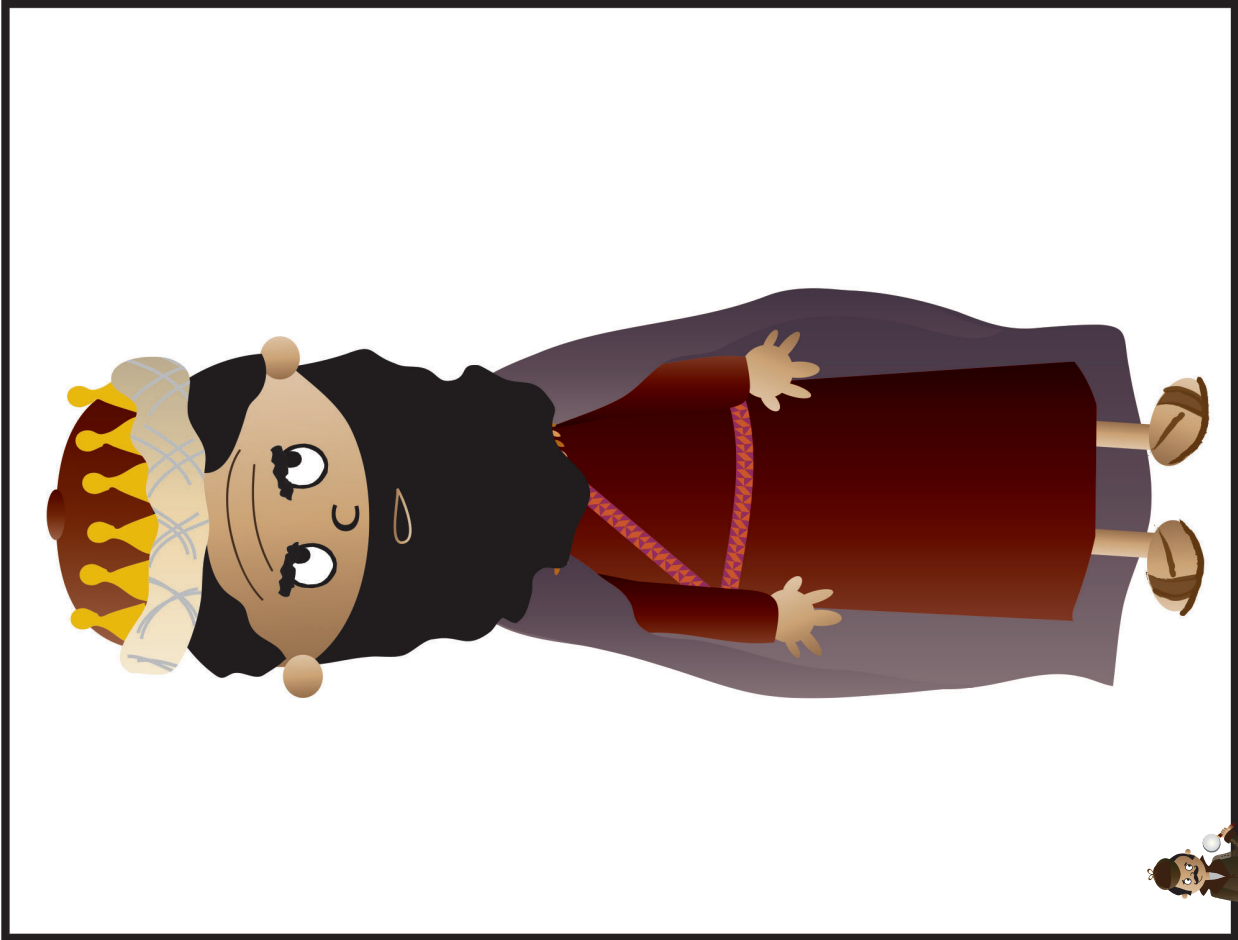

King Amon

VISUAL  
AID  
#5C

Place in  
DDD  
Bible™

take out  
Big  
Question  
Briefcase  
of BQB

VISUAL  
AID  
#5C

Place in  
DDD  
Bible™

take out  
Big  
Question  
Briefcase  
of BQB

DDD 12.5 Lesson 3 Listening Assignment Clue Picture 6 for kids

DDD 12.5 Lesson 3 Listening Assignment Clue Picture 5 for

# “The Case of the Lost Treasure” 2 Kings 22; 23:1-20; 24; 2 Chronicles 34:8-33



## Detective Dan's Listening Assignment #1

1. What was the treasure? And why was it hidden?
2. Who found it and what did they do with it?



## Detective Dan's Listening Assignment #2

**Psalms 119:11,15,16, ESV**

“I have stored up your word in my heart, that I might not sin against you. I will meditate on your precepts and fix my eyes on your ways. I will delight in your statutes; I will not forget your word.”

1. Who was supposed to hide God's Word in their hearts by writing down their very own copy of it? Why?
2. What happened when they did this? What happened when they didn't do this?

(more listening and discussion questions are included in the curriculum at [praisefactory.org](http://praisefactory.org))

**I. Moses was a very old man. For many years, the LORD had used him to lead the people of Israel. Moses led them out of slavery in Egypt, then up to great Mt. Sinai to meet with the LORD.**



**GO  
AWAY!**

**THE LORD  
IS THE ONE,  
TRUE GOD!**

**I. Moses was a very old man. For many years, the LORD had used him to lead the people of Israel. Moses led them out of slavery in Egypt, then up to great Mt. Sinai to meet with the LORD.**

**2. There, they made big, covenant promises. The LORD promised to always be their God, who would care for them. And the people promised to always be His people, who would love Him and keep His good laws.**





2. There, they made big, covenant promises. The LORD promised to always be their God, who would care for them. And the people promised to always be His people, who would love Him and keep His good laws.

**3. For forty, long years, Moses led the people through the dry, desert-y wilderness. Finally, came the wonderful day they were waiting for: the day when Moses brought them to the edge of the Promised Land. It was time to enter the good land the LORD promised to give them as their home.**



3. For forty, long years, Moses led the people through the dry, desert-y wilderness. Finally, came the wonderful day they were waiting for: the day when Moses brought them to the edge of the Promised Land. It was time to enter the good land the LORD promised to give them as their home.

**4. Moses had been a good leader. He had written down God's Word. He had taught the people to obey the LORD and His good laws.**

**But now, Moses' work was done. It was time for him to die and to go heaven to live with the LORD forever. So there, just outside the Promised Land, Moses gathered all the people together to teach them one last time.**



4. Moses had been a good leader. He had written down God's Word. He had taught the people to obey the LORD and His good laws. But now, Moses' work was done. It was time for him to die and to go heaven to live with the LORD forever. So there, just outside the Promised Land, Moses gathered all the people together to teach them one last time.

**5. “Love the LORD with all your heart, all your mind, and all your strength. Keep on learning God’s laws. Know them and obey them!”  
Moses urged the people of Israel.**

**“If you do, God will keep you as His special people. He will protect you. He will use everything you go through to do good in your lives and to show everyone how great He is,” Moses promised them.**

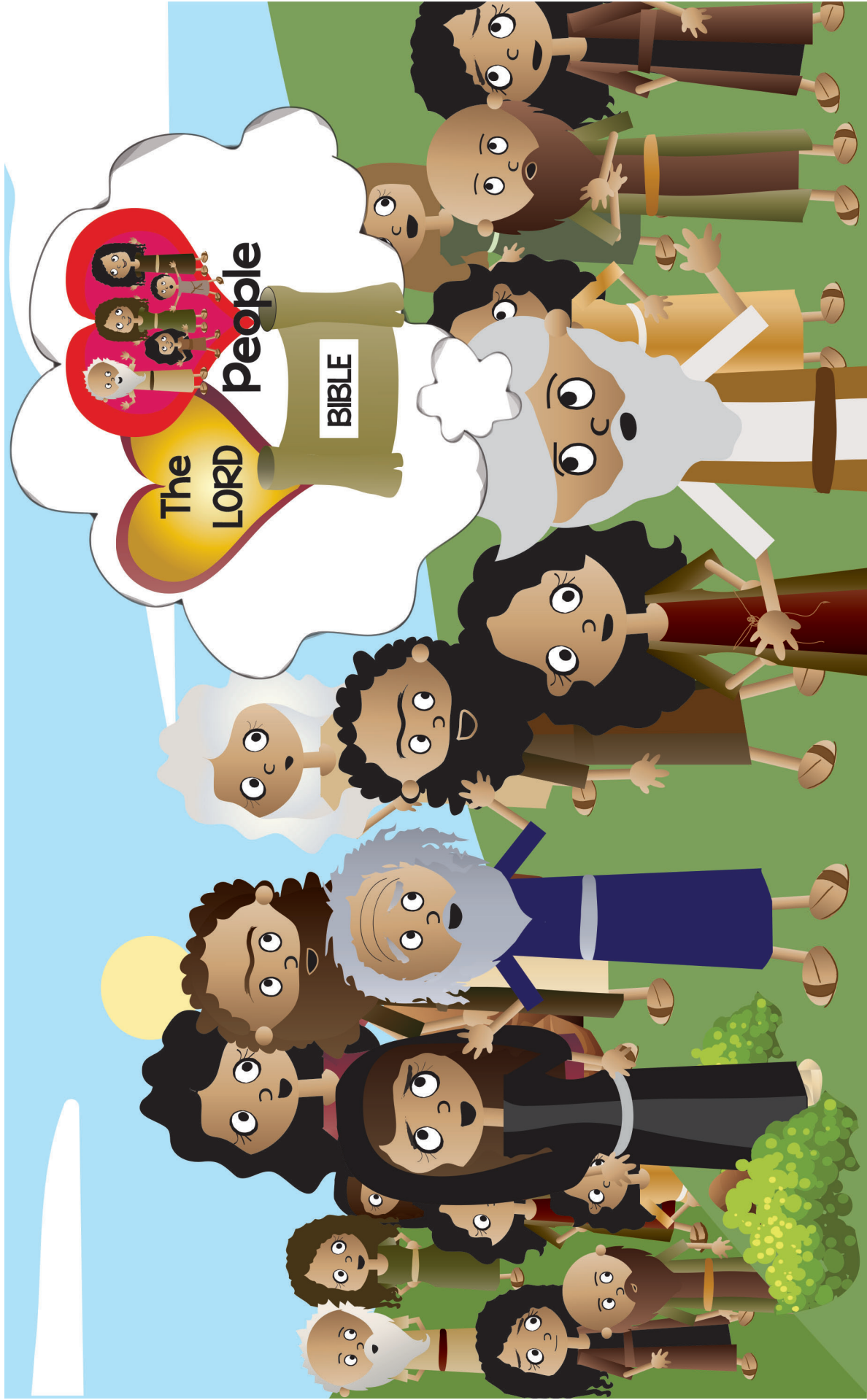

5. **“Love the LORD with all your heart, all your mind, and all your strength. Keep on learning God’s laws. Know them and obey them!”** Moses urged the people of Israel. **“If you do, God will keep you as His special people. He will protect you. He will use everything you go through to do good in your lives and to show everyone how great He is.”** Moses promised them.

**6. “And make sure your kings know God’s laws, too,” Moses warned them. “Each king should write down their own copy of God’s Word. Every, single word! This will help them know and obey God. This will help them be good kings for you,” Moses told the people.**





6. "And make sure your kings know God's laws, too," Moses warned them. "Each king should write down their own copy of God's Word. Every, single word! This will help them know and obey God. This will help them be good kings for you," Moses told the people.

**7. Moses knew there was nothing like God's Word. It is powerful and good. It is always true. It tells us how to live. It helps us know and love God. And God promises to bless those who obey it. God's Word is a treasure. A precious treasure! Moses wanted to make sure the people understood this.**



7. Moses knew there was nothing like God's Word. It is powerful and good. It is always true. It tells us how to live. It helps us know and love God. And God promises to bless those who obey it. God's Word is a treasure. A precious treasure! Moses wanted to make sure the people understood this.

**8. The people of Israel listened to Moses and said, "We will do everything you say. We will learn God's laws and obey them. We will tell our kings to write them down and obey them, too," they promised.**

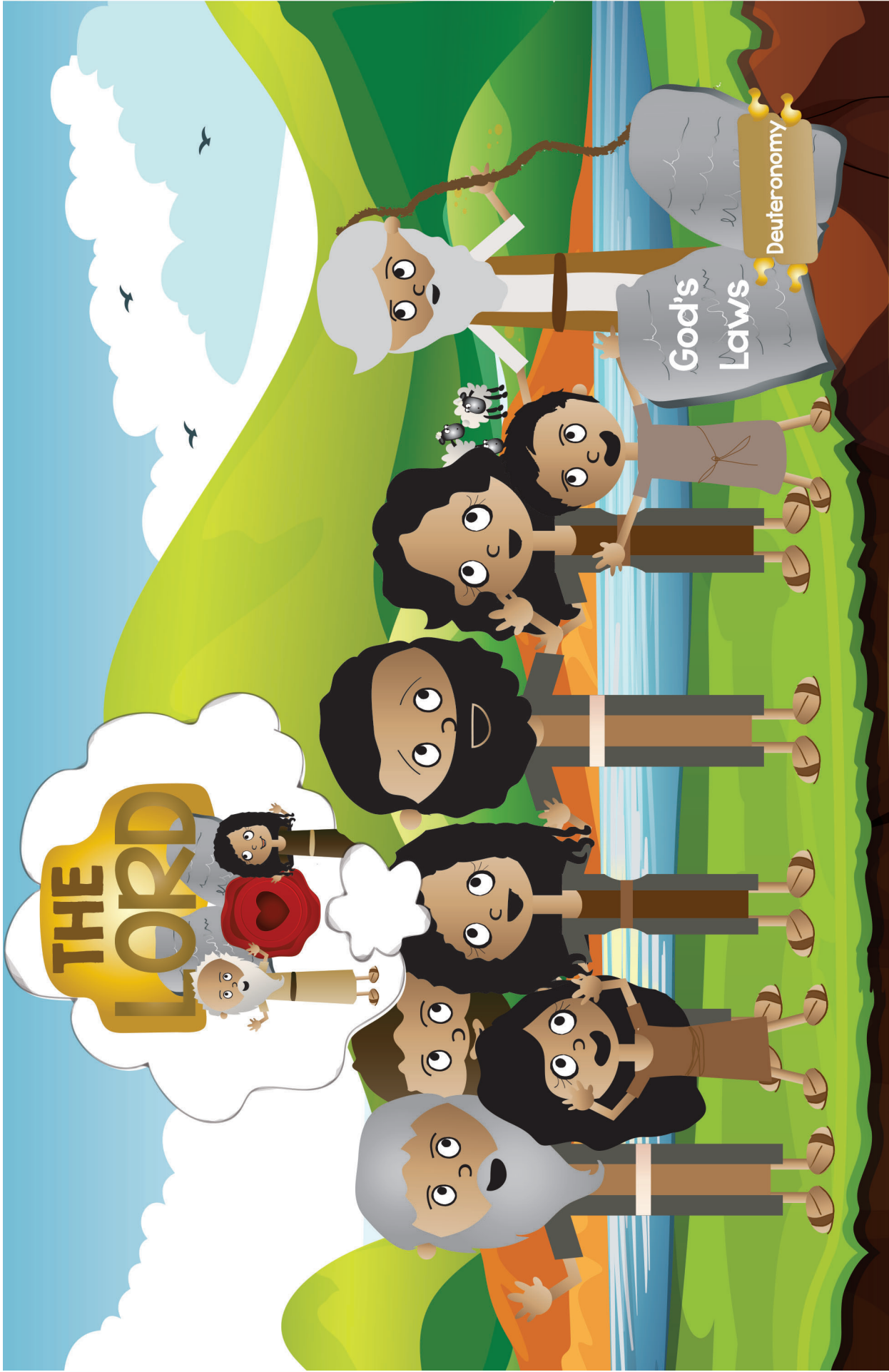

8. The people of Israel listened to Moses and said, "We will do everything you say. We will learn God's laws and obey them. We will tell our kings to write them down and obey them, too." they promised.

**q. But DID the people of Israel keep their promise? DID they learn God's Word and obey it? DID they have their kings write it down and obey it, too?**

**Well, sometimes they did; but many times, they didn't. They acted as if it didn't matter if they or their kings learned and obeyed God's Word.**



9. But DID the people of Israel keep their promise? DID they learn God's Word and obey it? DID they have their kings write it down and obey it, too? Well, sometimes they did; but many times, they didn't. They acted as if it didn't matter if they or their kings learned and obeyed God's Word.

**10. But it DID matter, as the people of Israel found out over and over! For whenever they learned and obeyed God's Word, they grew closer to the LORD. They worshipped Him and lived for Him. And the LORD blessed them with good things, their whole lives. The LORD also used His Word to make their kings good kings.**

**When they copied it down as the LORD told them to, He taught them His good ways and helped them live them out. They took good care of the people, and the LORD protected their land from all their enemies. Life was so good when the people and their kings learned and obeyed God's Word! The LORD blessed them in so many ways!**





10. But it DID matter, as the people of Israel found out over and over! For whenever they learned and obeyed God's Word, they grew closer to the LORD. They worshipped Him and lived for Him. And the LORD blessed them with good things, their whole lives. The LORD also used His Word to make their kings good kings. When they copied it down as the LORD told them to, He taught them His good ways and helped them live them out. They took good care of the people, and the LORD protected their land from all their enemies. Life was so good when the people and their kings learned and obeyed God's Word! The LORD blessed them in so many ways!

**II. But how very different life was when the people and their kings STOPPED learning God's Word and obeying it.**

**The people stopped worshipping the LORD and growing closer to Him. They stopped obeying God's good laws, too. They hurt each other and broke their promises to the LORD. The kings stopped copying down God's Word and reading it.**

**Without the LORD and His Word, they stopped being good kings. No longer did they take good care of the people. No longer did their enemies stay away. What sad times came upon them, just as the LORD said would happen!**



II. But how very different life was when the people and their kings STOPPED learning God's Word and obeying it. The people stopped worshipping the LORD and growing closer to Him. They stopped obeying God's good laws, too. They hurt each other and broke their promises to the LORD. The kings stopped copying down God's Word and reading it. Without the LORD and His Word, they stopped being good kings. No longer did they take good care of the people. No longer did their enemies stay away. What sad times came upon them, just as the LORD said would happen!

**12. Some of these kings even brought in the fake gods of their enemies and worshipped them instead.**

**They ordered the people to worship these fake gods and give their worship gifts to them. They let the Temple, the LORD's special worship place, fall apart. They didn't care about the LORD.**



12. Some of these kings even brought in the fake gods of their enemies and worshipped them instead. They ordered the people to worship these fake gods and give their worship gifts to them. They let the Temple, the LORD's special worship place, fall apart. They didn't care about the LORD.

**13. And what happened to God's Word when the kings and the people turned away from the LORD? They got rid of it! They threw it away like useless trash, instead of treating it like the treasure it was.**

**Oh, what terrible things the people and their kings had done! And oh, what terrible punishment they deserved for breaking their promises to God!**

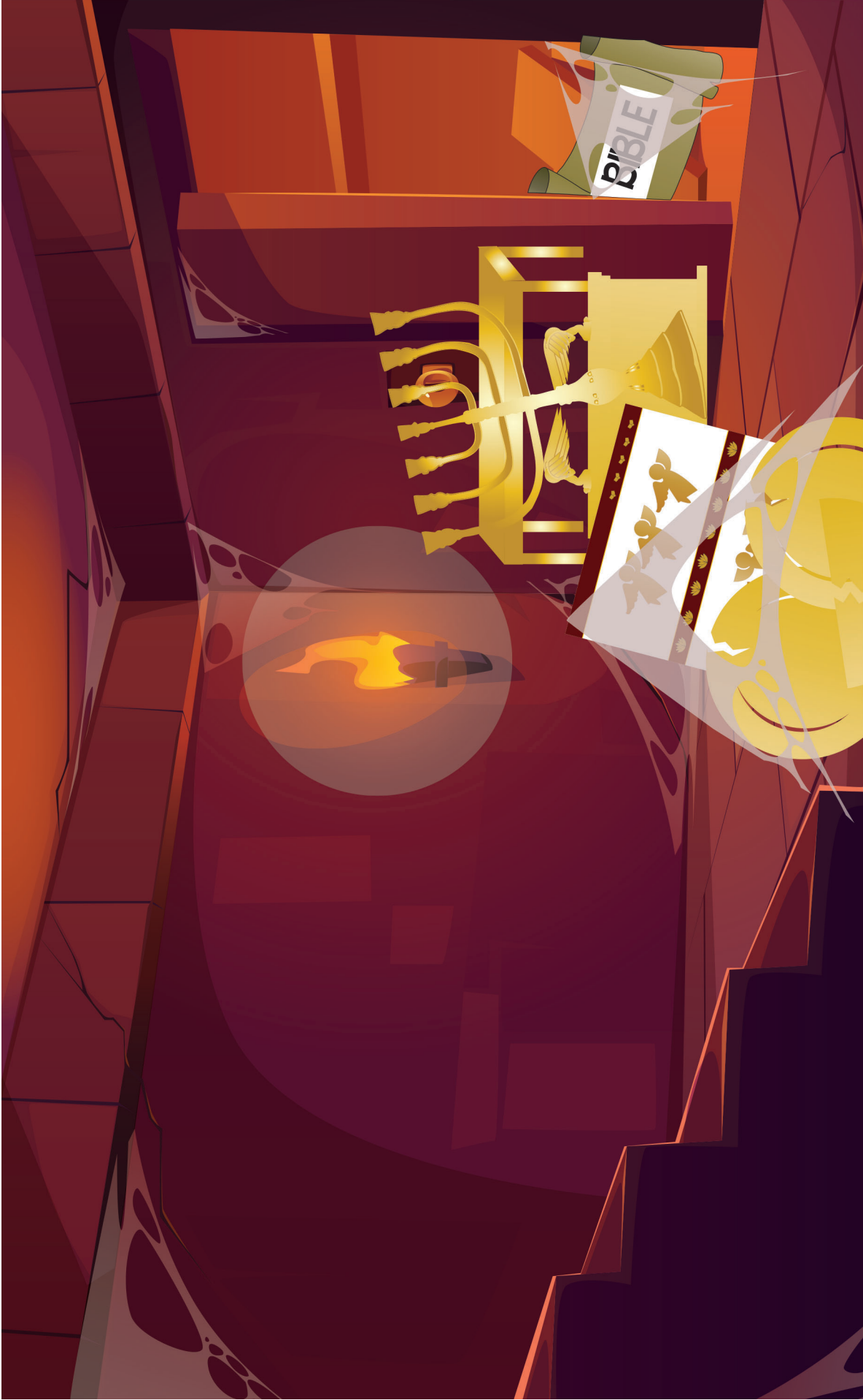

**13. And what happened to God's Word when the kings and the people turned away from the LORD? They got rid of it! They threw it away like useless trash, instead of treating it like the treasure it was. Oh, what terrible things the people and their kings had done! And oh, what terrible punishment they deserved for breaking their promises to God!**

**14. This is how things were when Josiah became king.**

**Josiah's father, Amon, had been one of the bad kings. He worshipped fake gods, and gave his worship gifts to them, instead of the LORD. He ordered the people to worship these fake gods, too. He forgot about God's Word and let it be lost. What a terrible king he was!**





14. This is how things were when Josiah became king. Josiah's father, Amon, had been one of the bad kings. He worshipped fake gods, and gave his worship gifts to them, instead of the LORD. He ordered the people to worship these fake gods, too. He forgot about God's Word and let it be lost. What a terrible king he was!

**15. But Josiah was very different from his father. While he was still just a little boy, he began to seek after the LORD. He turned away from those fake gods and turned to the LORD.**

# THE LORD



15. But Josiah was very different from his father. While he was still just a little boy, he began to seek after the LORD. He turned away from those fake gods and turned to the LORD.

**16. And when Josiah became king, he led the people in turning to the LORD, too.**

**“Get rid of these fake gods,” Josiah commanded his workers.  
“Worship the LORD,” Josiah told the people. “Give your worship gifts to Him, the one true God,” Josiah said.**



16. And when Josiah became king, he led the people in turning to the LORD, too. "Get rid of these fake gods," Josiah commanded his workers. "Worship the LORD," Josiah told the people. "Give your worship gifts to Him, the one true God," Josiah said.

**17. To the Temple, went the king's workers. Out went all the fake gods. "Smash, crash, crumble," the workers broke them into pieces and ground them into powder. No one would worship them again!**

**Then, "Bang, whack, thump," up went new wood and new stone as they fixed up the broken places in the Temple.**

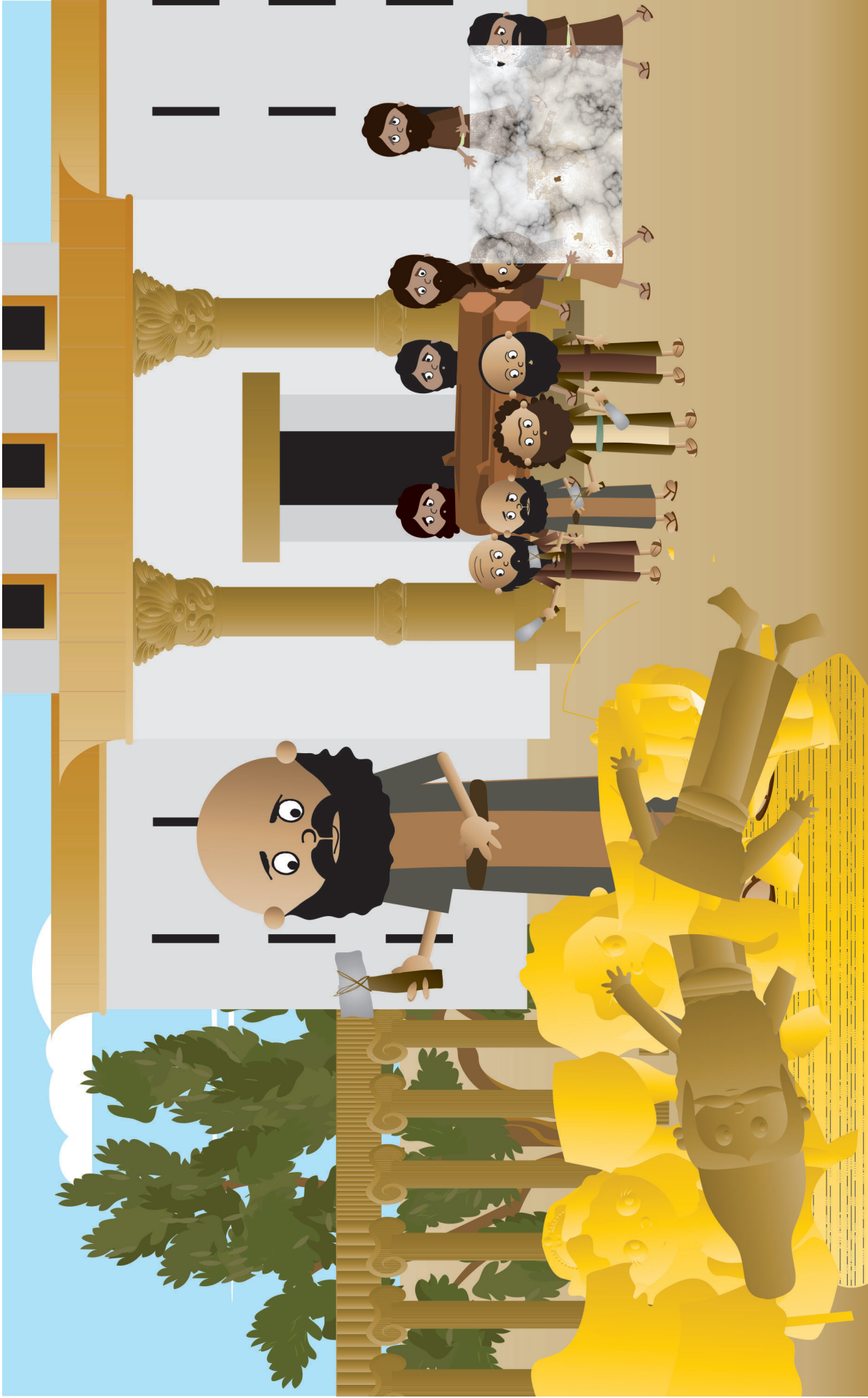

17. To the Temple, went the king's workers. Out went all the fake gods. "Smash, crash, crumble," the workers broke them into pieces and ground them into powder. No one would worship them again! Then, "Bang, whack, thump," up went new wood and new stone as they fixed up the broken places in the Temple.

**18. The beautiful, golden things used to worship the LORD were brought out again. They were cleaned up and made ready. The tables, the plates, the candlesticks, the altar, the wash basin... everything!**

**The workers worked and worked. What a lot there was to clean up and fix! And as they worked, they found a book, forgotten and hidden away. It was God's Word, the Bible!**





18. The beautiful, golden things used to worship the LORD were brought out again. They were cleaned up and made ready. The tables, the plates, the candlesticks, the altar, the wash basin... everything! The workers worked and worked. What a lot there was to clean up and fix! And as they worked, they found a book, forgotten and hidden away. It was God's Word, the Bible!

**19. Hilkiah, the Temple leader, brought God's Word to Shaphan, King Josiah's helper.**

**"I have found God's Word in the Temple. Take it." Shaphan took it and read it. Then, HE took it to King Josiah and read it to HIM.**

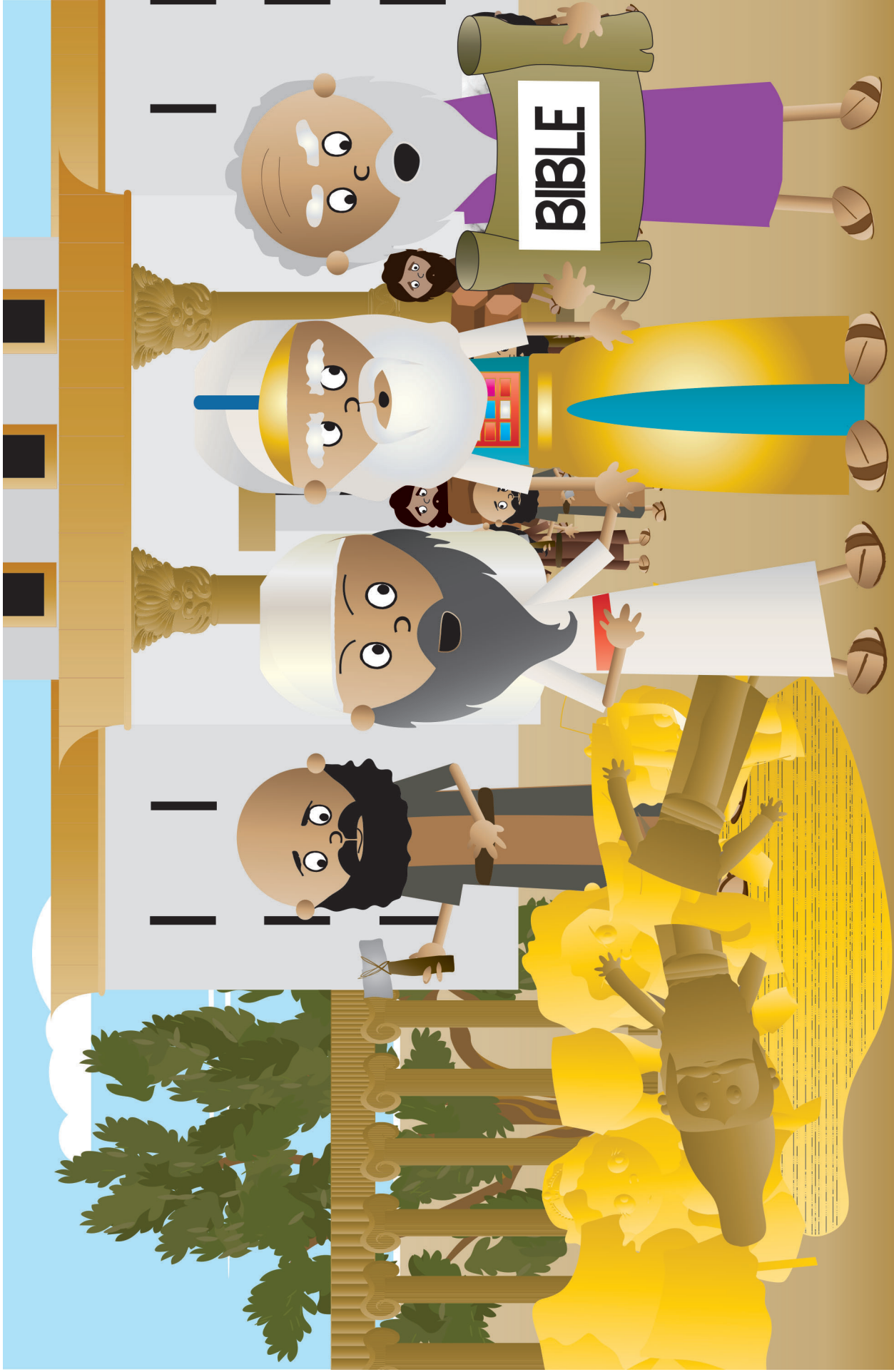

19. Hilkiah, the Temple leader, brought God's Word to Shaphan, King Josiah's helper. "I have found God's Word in the Temple. Take it." Shaphan took it and read it. Then, HE took it to King Josiah and read it to HIM.

**20. King Josiah listened to every word.**

**For the first time, Josiah heard how LORD created the world. He heard how the LORD had rescued the people from Pharaoh in Egypt and given them His good laws at Mt. Sinai. He heard about the big, covenant promises He made with the people of Israel to always be their God.**

**What wonderful stories these were! This book had been hidden away and forgotten. It had been treated like trash. But Josiah could see that this book was a treasure, more precious than gold. How happy he was to hear God's Word!**



20. King Josiah listened to every word. For the first time, Josiah heard how LORD created the world. He heard how the LORD had rescued the people from Pharaoh in Egypt and given them His good laws at Mt. Sinai. He heard about the big, covenant promises He made with the people of Israel to always be their God. What wonderful stories these were! This book had been hidden away and forgotten. It had been treated like trash. But Josiah could see that this book was a treasure, more precious than gold. How happy he was to hear God's Word!

**21. As King Josiah kept listening, his happiness turned to worry. Yes, the LORD had made big, covenant promises with the people of Israel to be their God; but, THEY had made promises with the LORD, too.**

**They had promised to worship Him and obey His good laws, but they had NOT done that. Nor had they learned God's Word or obeyed it as they had promised. The kings had NOT written God's Word and learned it either.**

**No! They had all forgotten the LORD and broken His good laws. Now, they all deserved the LORD's punishment. Uh, oh!**



21. As King Josiah kept listening, his happiness turned to worry. Yes, the LORD had made big, covenant promises with the people of Israel to be their God; but, THEY had made promises with the LORD, too. They had promised to worship Him and obey His good laws, but they had NOT done that. Nor had they learned God's Word or obeyed it as they had promised. The kings had NOT written God's Word and learned it either. No! They had all forgotten the LORD and broken His good laws. Now, they all deserved the LORD's punishment. Uh, oh!

**22. King Josiah was so upset that he stood up and tore his clothes. (That's what they used to do long ago when they were very, very upset—but we shouldn't do it!)**

**“Oh, no! What should we do?” said King Josiah. “We deserve God's terrible punishment for breaking our promises to Him!” he exclaimed.**





22. King Josiah was so upset that he stood up and tore his clothes. (That's what they used to do long ago when they were very, very upset—but we shouldn't do it!) “Oh, no! What should we do?” said King Josiah. “We deserve God’s terrible punishment for breaking our promises to Him!” he exclaimed.

**23. The LORD gave Josiah His answer through the prophetess Huldah.**

**“Yes, you deserve My punishment for breaking your promise to keep My laws, but I am a God of mercy,” the LORD said.**

**“Since you want to learn my Word and obey it, I will not punish the people as they deserve. And when I do finally punish them, I will use that punishment to bring them back to love and obey Me.” He promised.**

**King Josiah was so happy! He would learn God’s Word and obey it. He would teach the people of Israel to obey it, too. He was so glad that the LORD would keep them as His people!**



23. The LORD gave Josiah His answer through the prophetess Huldah. “Yes, you deserve My punishment for breaking your promise to keep My laws, but I am a God of mercy,” the LORD said. “Since you want to learn my Word and obey it, I will not punish the people as they deserve. And when I do finally punish them, I will use that punishment to bring them back to love and obey Me.” He promised. King Josiah was so happy! He would learn God’s Word and obey it. He would teach the people of Israel to obey it, too. He was so glad that the LORD would keep them as His people!

**24. So, at last, when the Temple was repaired, King Josiah gathered all the people together in front of it. Then he, himself, read out loud to them.**

**Can you guess what he read? He read God's Word to them. Every single word of it! As the people heard God's Word, God worked in their hearts. He helped them be sorry for their sins. He helped them turn back to Him and His good laws.**

**Then all together, King Josiah and the people prayed to the LORD, "We promise to worship You. We promise to learn Your Word and obey it." And so they did, all the days that Josiah was their king.**



24. So, at last, when the Temple was repaired, King Josiah gathered all the people together in front of it. Then he, himself, read out loud to them. Can you guess what he read? He read God's Word to them. Every single word of it! As the people heard God's Word, God worked in their hearts. He helped them be sorry for their sins. He helped them turn back to Him and His good laws. Then all together, King Josiah and the people prayed to the LORD, "We promise to worship You. We promise to learn Your Word and obey it." And so they did, all the days that Josiah was their king.

## DDD 12.5 Simple Story Scenes

# "The Case of the Lost Treasure" 2 Kings 22; 23:1-20; 24; 2 Chronicles 34:8-33

# SOLVED



## Detective Dan's Listening Assignment #1

1. What was the treasure? And why was it hidden? It was a book: the Bible, God's Word. It was hidden because King Amon and the people didn't care about it. They put it in a room and forgot about it until it was lost.

2. Who found it and what did they do with it? King Josiah's workers found it. They gave it to the king to read. He asked God for forgiveness and helped the people obey it again.

**For You and Me:**  
God's Word is filled with good things for God's people, who lived long ago. But it is filled with good things for us, too. God's Word can teach us. From it, we can learn about God and how He wants us to live. He can use it to help us turn away from our sins and put our trust in Jesus as our Savior. It can be a great treasure that God uses to bless us every day of our lives.



## Detective Dan's Listening Assignment #2

Psalms 119:1,15,16, ESV

"I have stored up your word in my heart, that I might not sin against you. I will meditate on your precepts and fix my eyes on your ways. I will delight in your statutes; I will not forget your word."

1. Who was supposed to hide God's Word in their hearts by writing down their very own copy of it? Why? The kings so they would know God's Word and lead the people in loving and obeying God.

2. What happened when they did this? What happened when they didn't do this? God helped them to love Him. He helped them obey it. He blessed the people. But, when they didn't, they turned away from loving God and obeying His Word. The people suffered.

**For You and Me:**

God didn't just want people long ago to know His Word and obey it from their hearts. He wants us to, also. God loves to work in our hearts as we learn His Word. He loves to use it to help us turn away from our sins and trust in Jesus as our Savior. He loves to use it to help us know Him and to live for Him. Ask Him to use His Word to work in your heart! He loves to answer this prayer:

DDD 12.5 Simple Story Scenes



How Should God's People Live?  
They Should Live Like Jesus...  
By Learning God's Word and Obeying It!

# The Gospel



There is so much to love about the Bible, God's Word! Through it, we can learn the truth about God and about ourselves. We learn that we have all chosen to disobey God and deserve His punishment.

But God's Word also tells us about God's mercy in sending Jesus, His Son, to be the Savior we need. It tells us that Jesus lived a perfect life, then on the cross, He gave it up to pay for the sins of God's people. On the third day, Jesus rose from the dead. He had really beaten sin and death for them!

Best of all, the Bible tells us that now, whoever turns away from their sins and trust in Jesus as their Savior can become God's people. Their sins are forgiven. They get to know God in their hearts, now. And one day, they will go live with Him forever.

God can help you become one of His people, too. Ask Him! He loves to help us!



DDD 12.5 Simple Story Scenes

# A Prayer

A God, we praise You for being the Giver of Your Word, the Bible. Through it, we can see how amazing You are!

C God, please forgive us for not loving Your Word as we should. Too many times we choose to not read Your Word but do other things instead. Too many times, even when we do read Your Word, we forget it and do not obey it. We need a Savior!

T Thank You, God, for telling us so much about Yourself and Your great plans through the Bible. Thank You for telling us about Jesus and how we can be saved. Thank You for showing us how to live and promising to help us through Your powerful Word.

S God, please work in our hearts. Help us turn away from our sins and trust in Jesus as our Savior. Help us to love Your Word, the Bible. Send Your Holy Spirit to help us understand it and obey it. Help us to live like You want us to live. In Jesus' name we pray, Amen.



DDD 12.5 Simple Story Scenes

# **DEEP DOWN DETECTIVES**



**Visual Aids**

**Unit 12,**

**Bible Truth 6**

## About the Deep Down Detectives Visual Aids

### How Are They Used?



The Deep Down Detectives Visual Aids book is a companion resource to be used alongside the Deep Down Detectives Core Curriculum book for each unit. These colorful pictures are used in presenting the key concepts; telling the Bible stories; and, in playing the Bible Story Review games.

### What Do They Include?



**There are four different resources included in this book:**

- 1. Key Concept Visual Aids**-- colorful signs of the Big Question and Answer, the Bible Truth, the Bible verse, and the Listening Assignments to use with the 3 lessons for each Bible Truth.
- 2. The Story Scenes.** Notice that each scene is numbered and that there is a brief summary of the story that corresponds to the picture. You can actually just tell the story in a simple way by using only the text at the bottom of each Story Scene.
- 3. Directions** for making the Deep Down Detectives "Bible" Folder and the **back/front images** to paste in place when making it. (Larger back/front images are found online with the curriculum.)
- 4. Directions** for how to make a homemade flannelgraph storyboard and sturdy Story Scene pictures are found in the back of this book.

### Ready, Set, Rip It Out!

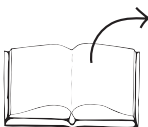

This book is meant to be ripped up and made into your visual aids. The key concept signs can be cut out and laminated or slipped into sheet protectors. The Story Scenes can be put in sheet protectors or laminated, too.

### Store It!



Deep Down Detectives is a curriculum that can be used over and over. Store your visual aids and storyboard pictures after using them and they will serve you for many years. We store ours in manilla envelopes and then put them (along with all the rest of the curriculum) in magazine files, labelled by Bible Truth. If you have multiple classes using the curriculum, store each set of resources in separate manilla envelopes. This will make prep much simpler, second time around.

### Replacement Story Scene Pictures



You can always purchase this book again or simply go online and print out any scenes that go missing.

### Other Options



You can also choose to tell the story in a more traditional flannelgraph way by using your own flannelgraph figures or by purchasing/free downloading the Storyboard Pictures (large and small format size available). This is more complex and requires more preparation, but some love it. And, it does allow for kids to interact more by helping to place pictures up on the board as you tell the story.

**Unit 12: God's People Live for Him**

**Unit Big Question (and Answer):** How Should God's People Live? They Should Live Like Jesus!

**Unit Bible Verse:** "Be imitators of God, as beloved children. And walk in love, as Christ loved us and gave himself up for us." --Ephesians 5:1-2, ESV

**Bible Truth 6 Concept: They Should Live Like Jesus... By Saying "No" to Disobeying God!**

Jesus is the perfect Son of God, but when He lived on earth, He was tempted to disobey God just as we are. Sometimes, God's plan for Jesus was very hard. Jesus was tempted disobey God, His Father, and do something easier. God's enemy, Satan, knew just what kinds of things to tempt Jesus with. Oh, how he wanted Jesus to disobey God! He did NOT want Jesus to be our Savior!

But no matter what the temptation was, Jesus always said "no" to it. He prayed to God, His Father, to help Him. He remembered God's Word and it made Him strong to always say "no" to disobeying God. He never, ever disobeyed God, so He could be our perfect Savior.

God's people are often tempted to disobey God, too. They want to love God. They want to obey Him. They have the Holy Spirit living in their hearts, helping them; but (unlike Jesus), sin is very strong in their hearts, too.

God wants His people to do what Jesus did when they are tempted. He wants them to pray to Him and ask for His help. He wants them to remember His Word, the Bible. His Holy Spirit living in their hearts can help them say "no" to sin. And when they do give in to temptation, His Holy Spirit can comfort them with God's forgiveness.

When we turn away from our sins and trust in Jesus as our Savior, God promises to help us say "no" to disobeying God, too. And, He promises to forgive our sins, even when we do disobey Him. Thank You, God!

**Bible Truth 6 Bible Verse: 1 Corinthians 10:13, ESV**

"No temptation has overtaken you that is not common to man. God is faithful, and he will not let you be tempted beyond your ability, but with the temptation he will also provide the way of escape, that you may be able to endure it."

**Learn a Little:** "God is faithful, and he will not let you be tempted beyond your ability."

**Meaning**

God's people will be tempted to sin every day of their lives. Their temptations are common to man--that is, they will be tempted to sin against God, just like everyone else. But God's people can be encouraged that God is always there to help them say "no." He promises that He will never let them be tempted more than they can bear. With any temptation they face, He promises to provide a way of escape, so they can endure the temptation without sinning. How good, merciful, and powerful is the Lord! We can be God's people when we turn away from our sins and trust in Jesus as our Savior. He can help us say "no" to temptation, too.

**Bible Truth 6 ACTS Prayer**

- A** God, we praise You for Jesus, Your Perfect Son, who never, ever disobeyed You, no matter how tempting it was.
- C** God, please forgive us for not saying "no" to disobeying You. Many times, when we are tempted, we choose to forget Your good ways and go ahead and do what we want to do. We need a Savior!
- T** Thank You, God, for promising to help Your people when they are tempted to do wrong. You promise to always provide them with a way out of sin. Thank You, that we can become Your people through Jesus, too, and You will help us.
- S** God, please work in our hearts. Help us turn away from our sins and trust in Jesus as our Savior. Help us to say "no" to disobeying You when we are tempted. Help us to choose to live for You, instead, like Jesus did. In Jesus' name we pray, Amen.

---

**Bible Truth 6 Story****The Case of the Escape that Waited**

*1 Samuel 17:19,23-24,27,31; 2 Samuel 5-6*

---

**Songs Used in Bible Truth 6**

Big Q & A 12 Song

Big Question 12 Song: How Should God's People Live?

Big Question 12 Bible Verse Song: Walk in Love Ephesians 5:1-2, ESV

*Extra Big Question 12 Bible Verse Song: Let Everyone Who Names the Name 2 Timothy 2:19,22, ESV*

Big Question 12 Hymn: Trust and Obey, v.1

Big Question 12 Praise Song: I Have Decided to Follow Jesus

Bible Truth 6 Bible Verse Song: No Temptation 1 Corinthians 10:13, ESV

*Extra Bible Truth 6 Bible Verse Song: No Temptation Has Overtaken You 1 Corinthians 10:13, ESV*

*Extra Bible Truth 6 Bible Verse Song: Count It All Joy James 1:2-4, ESV*

*listen to or download songs for free at <https://praisefactory.org>: Deep Down Detectives Music page*



**The Case of the Escape that Waited**

1 Samuel 17:19,23-24,27,31; 2 Samuel 5-6



**Story-telling Tips**

Ahead of time:

1. Read the Bible verses and story. Pray!
2. Choose story action cues and prepare storyboard figures/story scenes, if using. (In Visual Aids book)
3. Practice telling story with the storyboard pictures, timing your presentation. Shorten, if necessary.

During your presentation:

1. Maintain as much eye contact as possible as you tell the story.
2. Put up storyboard figures/add story action cues/hold up storybook scenes as you tell the story. Allow the children to help you put them on the board, if desired.
3. Include the children in your story with a few questions about what they think will happen or words/concepts that might be new to them.
4. Watch the kids for signs that their attention span has been reached. Shorten, if necessary.

**INTRODUCTION/ LISTENING ASSIGNMENTS**

**“Our story is called: The Case of the Escape that Waited. Here is your listening assignment.”** Read from Detective Dan’s Listening Assignment signs, but questions are summarized below:

**Detective Dan’s Lesson #1 Listening Assignment:**

I need to know:

1. Who needed to escape? Who did he need to escape from?
2. How could he have escaped? Why did he wait?

**Detective Dan’s Lesson #2 Listening Assignment:**

**Our Bible Verse is 1 Corinthians 10:13:**

“No temptation has overtaken you that is not common to man. God is faithful, and he will not let you be tempted beyond your ability, but with the temptation he will also provide the way of escape, that you may be able to endure it.”

I need to know:

1. Who was tempted to disobey God? How?
2. How did God help him and provide him a way out?

**Detective Dan’s Lesson #3 Listening Assignment:**

I found six clues, but two of them are **NOT** in the story.

They are: a harp, a rabbit, Goliath, a water jar, a pumpkin, and a spear. *Hold each of them up for the children to see as you identify them.*

I need to know:

1. Which four belong in the story and which two don’t?
2. Who kept asking God for help to can you say no keep saying no to temptation? How did God answer his prayers?

**Read the assignment questions, THEN SAY,**

“Ok, Deep Down Detectives! Put on your best listening ears and see if you can hear the answers to Detective Dan’s questions. When I finish telling the story, we will see if we can answer all the questions.”

*Read the Bible Truth story, answer questions, present the gospel and lead in prayer. Answers to questions; the gospel; and, ACTS prayer are included with the story text.*

**The Case of the Escape that Waited** *1 Samuel 17:19,23-24,27,31; 2 Samuel 5-6*

---

David was quite a man! He was a good shepherd who protected his sheep. He was a brave fighter who fought off enemies, whether they were great giants like Goliath, or even whole armies. He sang and played the harp, making up beautiful songs for God.

But most of all, David was a man after God's own heart.

What does it mean to be a man after God's own heart? Well, it means that David loved God and wanted to obey Him, even when it was very tempting to disobey Him.

---

David's people, the people of Israel, loved David! They were proud of how he protected his sheep from fierce, wild animals, like lions and bears. They praised David for being a brave fighter who fought off their powerful enemies. They loved David's songs and sang them to God.

They were glad that David was a man after God's own heart—who loved God and wanted to obey Him, even when it would be very tempting to disobey Him. They could see that God was pleased with David, too. God helped David in many special ways.

---

Yes, it seemed that EVERYONE in Israel loved David; but, that was not quite true. There was one man among the people of Israel who certainly did NOT love David.

Who was this man? It was none other than Saul, the king of Israel! Yes, King Saul disliked David because he was jealous of him. (Jealous means wishing you had what someone else has.)

---

Saul's jealousy of David grew bigger and bigger until it turned into anger and hate. David seemed to have everything that HE used to have, and Saul hated that.

Before David came, who did the people praise? They had praised HIM, King Saul! They praised HIM for being a brave fighter and for being Israel's first king. They praised HIM as the man God helped in special ways. And, oh, how King Saul loved the people's praise!

But now, all that had changed. When Saul had been tempted to disobey God, he didn't say "no." He said "yes"! Saul chose to sin against God and His good ways over and over. God warned Saul many times to turn away from disobeying Him. But what do you think Saul did? Saul kept on disobeying God. How sad!

*Can you guess?*

**Saul kept on disobeying God. How sad!**

---

So at last, after disobeying God over and over and over, the prophet Samuel came to Saul with some very sad news. "The LORD says, 'Because you have chosen to keep on disobeying Me, I'm going to make David and his sons the kings over Israel, instead of your family. No longer will you receive the special help I give My kings. Those days are gone for you,'" Samuel told Saul.

This made King Saul even MORE jealous! Now, he hated David even more. Saul would NOT let David be king. He would get rid of David! He would make sure HIS family, not David's, would be the kings over Israel!

*Story with lines separating paragraphs (text in bold, optional interaction cues in italics)*

---

**King Saul decided to kill David. He threw a long spear at him. Oh, no! Did Saul hit David?**

*What do you think?*

**No, he did not! God protected David and he got away!**

---

**Next, King Saul sent men to get rid of David as he slept. Oh, no! Did the men get David?**

*What do you think?*

**No, they did not! God protected David. David's wife, Michal, helped David escape.**

---

**Now David knew he was not safe anywhere near King Saul. There was only one thing he could do. He must run far, far away. So, away from the king's palace, away from the cities, and out into the dry, desert-y wilderness, David ran. He ran away to where no one lived. Surely King Saul would give up and leave David alone out there. But did he?**

*What do you think?*

**But King Saul did NOT! He was determined to get rid of David! So, King Saul and his soldiers went out into that dry, desert-y wilderness hunting for David. Nothing would stop King Saul from getting rid of David!**

---

**What a hard life David lived! Every day, Saul and his soldiers were after him. He was always on the run. "Run, David, run! Hide, David, hide!"**

**Where would David make his home? Where would he sleep?**

*Can you guess?*

**David had no home. He slept on the ground, or sometimes in a cave. David couldn't rest anywhere for long. Saul and his soldiers were never far behind. David had to keep moving and stay alert!**

---

**And where in that big, dry, desert-y wilderness could David find food and water?**

*Can you guess?*

**It wasn't easy. Sometimes, there were only hoppy bugs like locusts to eat! Wriggle, wriggle! Crunch, crunch! Ugh!**

---

**God had once called David a man after His own heart, a man who loved God and wanted to obey Him. But NOW what David was thinking inside his heart, with King Saul after him, day after day after day? Did he STILL love God and want to obey Him? David knew that the LORD didn't want him to hate Saul or hurt him. But, oh, it must have been very tempting to want to both hate and hurt Saul after all he had done.**

**And what would happen if David DID get a chance to kill Saul? Would he keep saying "no" to disobeying God, or would he kill Saul and be rid of him, once and for all?**

*What do you think?*

*Story with lines separating paragraphs (text in bold, optional interaction cues in italics)*

---

**One night, David and his soldier friend, Abishai, found the place where King Saul and his soldiers were sleeping. They tip-toed around all the sleeping soldiers until they came to King Saul, himself.**

**Right next to King Saul's head were a water jar and a big spear. Tempting thoughts came into David's heart. He could use the spear and even kill Saul. What would David do now? How mean Saul had been to him! How tired David was of running away from Saul! This would be an easy way for David to finally get rid of Saul.**

**Abishai agreed with those tempting thoughts. "Let's get rid of King Saul," Abishai urged David. David picked up the water jar and the spear. What would he do with them next?**

*What do you think David will do?*

---

**The LORD helped David NOT give into the temptation to disobey Him and hurt Saul. With jar and spear in hand, David led Abishai away from the camp.**

**When they were a safe distance away from the Saul and his soldiers, David woke them up with a shout. "King Saul, here are your water jar and your spear. I could have killed you with them, but I didn't," David yelled. "Send a man here to me and I will give them back to you. But please, stop trying to kill me. I've done nothing to you," David pleaded.**

**Did Saul stop trying to kill David?**

*What do you think?*

**I'm sad to say that he did NOT! But even so, David kept on being a man after God's own heart: he kept saying "no" to disobeying God. He waited for God's perfect timing to rescue him.**

---

**At last, that perfect timing did come. Saul died, and, David's days of running were over.**

**NOW, what was David thinking in his heart? Would he celebrate that Saul was dead? It would be tempting to be happy about that.**

*What do you think David did?*

**But David said "no" to that temptation, too. David was sad for Saul. He even taught the people a special song to honor him at his funeral.**

---

**And not long after Saul died, the people of Israel made David their king. Everyone celebrated with fig cakes and roast meat. They sang songs of praise to the LORD and set up His special meeting place in Jerusalem near David's palace. And who led the people in praising the LORD that day?**

*Can you guess?*

**Why, it was King David, himself! He wanted all the people to be people after God's own heart: people who loved God and wanted to obey Him, even when it was very, very hard.**

**Cracking the Case:** (story wrap-up for Listening Assignments)

It's time to see how we did with our Listening Assignment.

**Detective Dan's Lesson #1 Listening Assignment:**

I need to know:

**1. Who needed to escape? Who did he need to escape from and why?** David needed to escape from King Saul. Saul was jealous and wanted to kill David.

**2. How could he have escaped? Why did he wait?** David could have killed Saul, but he knew that was wrong. He chose to wait for the LORD to rescue him, in His perfect timing.

**For You and Me:**

David waited a long time for God to provide his escape from King Saul. How hard it must have been to wait! God helped David wait. He helped him say 'no' to the temptation to get rid of King Saul his own way. And how God blessed David when he waited for His perfect timing! Maybe we will never have someone chasing us and trying to kill us, like David did. Maybe we will never be tempted to kill anybody, like he was. But we have plenty of other temptations that come our way. Every day brings its own set of temptations to disobey God and His good ways. God helped David and He can help us. He can help us turn away and trust in Jesus as our Savior. This is how we become God's people. And, He can help us to keep on saying 'no' to disobeying Him and to keep on living His good way, instead of giving in to sin.

**Detective Dan's Lesson #2 Listening Assignment:****Our Bible Verse is 1 Corinthians 10:13, ESV:**

"No temptation has overtaken you that is not common to man. God is faithful, and he will not let you be tempted beyond your ability, but with the temptation he will also provide the way of escape, that you may be able to endure it."

I need to know:

**1. Who was tempted to disobey God? How?** David was. He was tempted to get rid of King Saul his own way.

**2. How did God help him and provide him a way out?** God helped him say 'no' to temptation. He helped David wait and trust. And in His perfect timing, God, Himself, provided the way out from King Saul.

**For You and Me:**

David waited a long time for God to provide his escape from King Saul. How hard it must have been to wait! God helped David wait. He helped him say 'no' to the temptation to get rid of King Saul his own way. And how God blessed David when he waited for His perfect timing! Maybe we will never have someone chasing us and trying to kill us, like David did. Maybe we will never be tempted to kill anybody, like he was. But we have plenty of other temptations that come our way. Every day brings its own set of temptations to disobey God and His good ways. God helped David and He can help us. He can help us turn away and trust in Jesus as our Savior. This is how we become God's people. And, He can help us to keep on saying 'no' to disobeying Him and to keep on living His good way, instead of giving in to sin.

**Detective Dan's Lesson #3 Listening Assignment:**

I found six clues, but two of them are **NOT** in the story. They are: a harp, a rabbit, Goliath, a water jar, a pumpkin, and a spear. *Hold each of them up for the children to see as you identify them.*

I need to know:

**1. Which four belong in the story and which two don't?** The harp, Goliath, the water jar and the spear belong. The rabbit and the pumpkin do not.

**For You and Me:**

David waited a long time for God to provide his escape from King Saul. How hard it must have been to wait! God helped David wait. He helped him say 'no' to the temptation to get rid of King Saul his own way. And how God blessed David when he waited for His perfect timing! Maybe we will never have someone chasing us and trying to kill us, like David did. Maybe we will never be tempted to kill anybody, like he was. But we have plenty of other temptations that come our way. Every day brings its own set of temptations to disobey God and His good ways. God helped David and He can help us. He can help us turn away and trust in Jesus as our Savior. This is how we become God's people. And, He can help us to keep on saying 'no' to disobeying Him and to keep on living His good way, instead of giving in to sin.

**The Gospel** (story wrap-up if NOT using Listening Assignments)**Our Bible Truth is:  
How Should God's People Live?  
They Should Live Like Jesus...  
By Saying "No" to Disobeying God!**

Our story today tells us about a time when David said "no" to disobeying God. But you know, David was not a perfect man. He was a man after God's own heart, but he was disobeyed God, just like you and me. Yes, there were many times when David sinned against God, just like we do. David, like us, needed a Savior to save him from the punishment he deserved for his sins.

Who was the Savior that David trusted God to send? It was Jesus! Yes, David looked forward to the day when Jesus would come! God forgave David's sins through his faith in this the coming Savior. God can forgive our sins through Jesus, too. How? When we turn away from disobeying God and trust Jesus as our own Savior! Isn't that good news!

*Close in prayer.*

**Closing ACTS Prayer**

- A** God, we praise You for giving us Jesus so we can know how we should live. He lived a perfect life!
- C** God, please forgive us for not saying "no" to disobeying You. Many times, when we are tempted, we choose to forget Your good ways and go ahead and do what we want to do. We need a Savior!
- T** Thank You, God, for promising to help Your people when they are tempted to do wrong. You promise to always provide them with a way out of sin. Thank You, that we can become Your people through Jesus, too, and You will help us.
- S** God, please work in our hearts. Help us turn away from our sins and trust in Jesus as our Savior. Help us to say "no" to disobeying You when we are tempted. Help us to choose to live for You instead, like Jesus did.

In Jesus' name we pray, Amen.

**Go to Lesson Plan, p.9 for the script to the rest of the lesson.**

# How should God's people live?

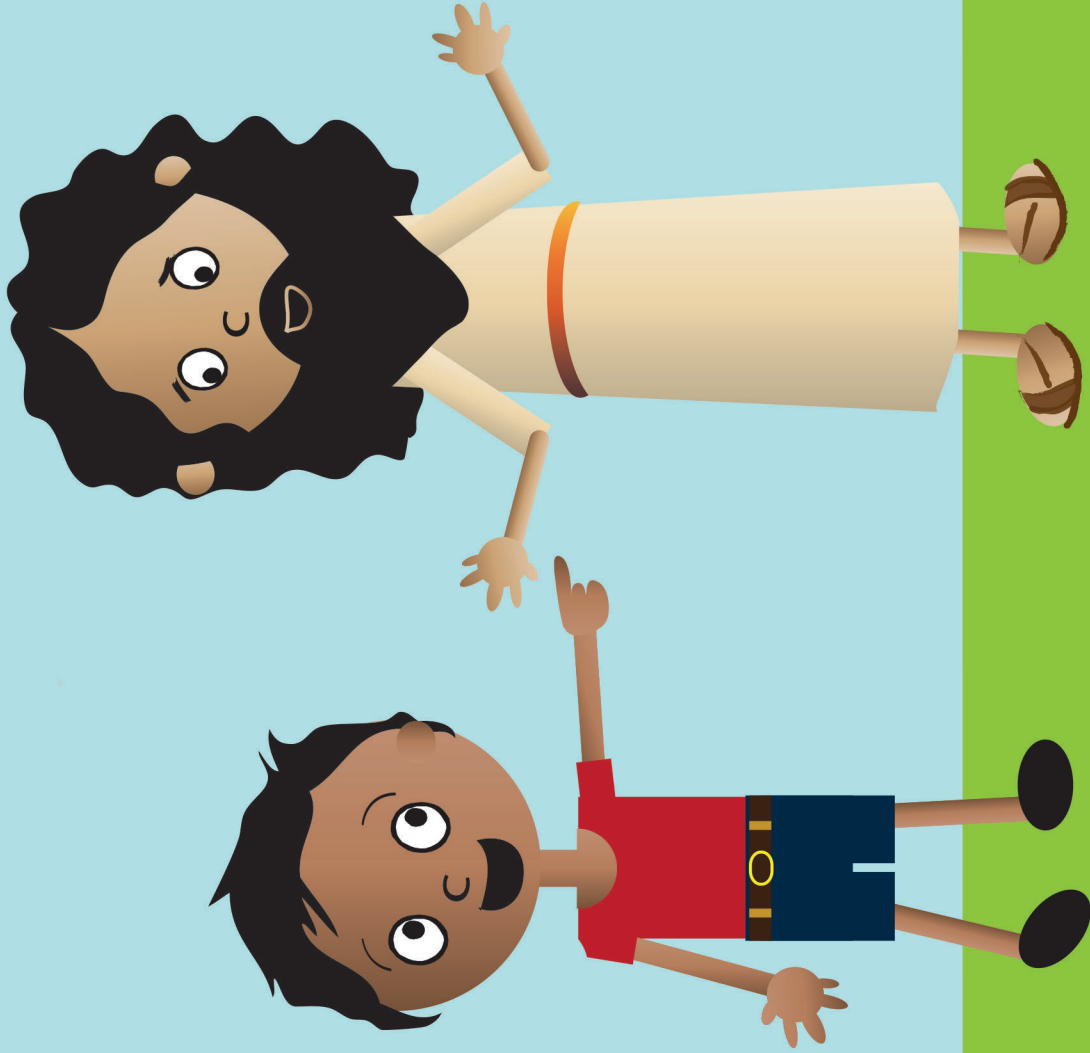

ANSWER:

**They should live like Jesus!**

VISUAL  
AID  
**#1**  
take out  
BIG  
QUESTION  
of BQB

## The Big Question

*Hold up the Big Question sign for all the children to see, and say:*

The Big Question we are investigating today is Big Question

Number 12:

**How Should God's People Live?**

and the Answer is:

**They Should Live Like Jesus!**

### **Meaning:**

We become God's people when we turn away from our sins and trust in Jesus as our Savior. When we do, God forgives our sins, and we begin a whole new way of life. God's people no longer live life just to please themselves. They want to honor God with their whole lives, like Jesus did. They seek to love God most of all and love all people, too.

Let's sing our Big Question Song: "

## Big Q & A 12 Song

*DDD ESV Songs 12, track 12*

*(adapted version of "Pop, Goes the Weasel")*

How should God's people live each day?

They should live like Jesus!

How should God's people live each day?

How should God's people live each day?

How should God's people live each day?

They should live like Jesus!



# BIG QUESTION 12: Eight truths about how God's people live

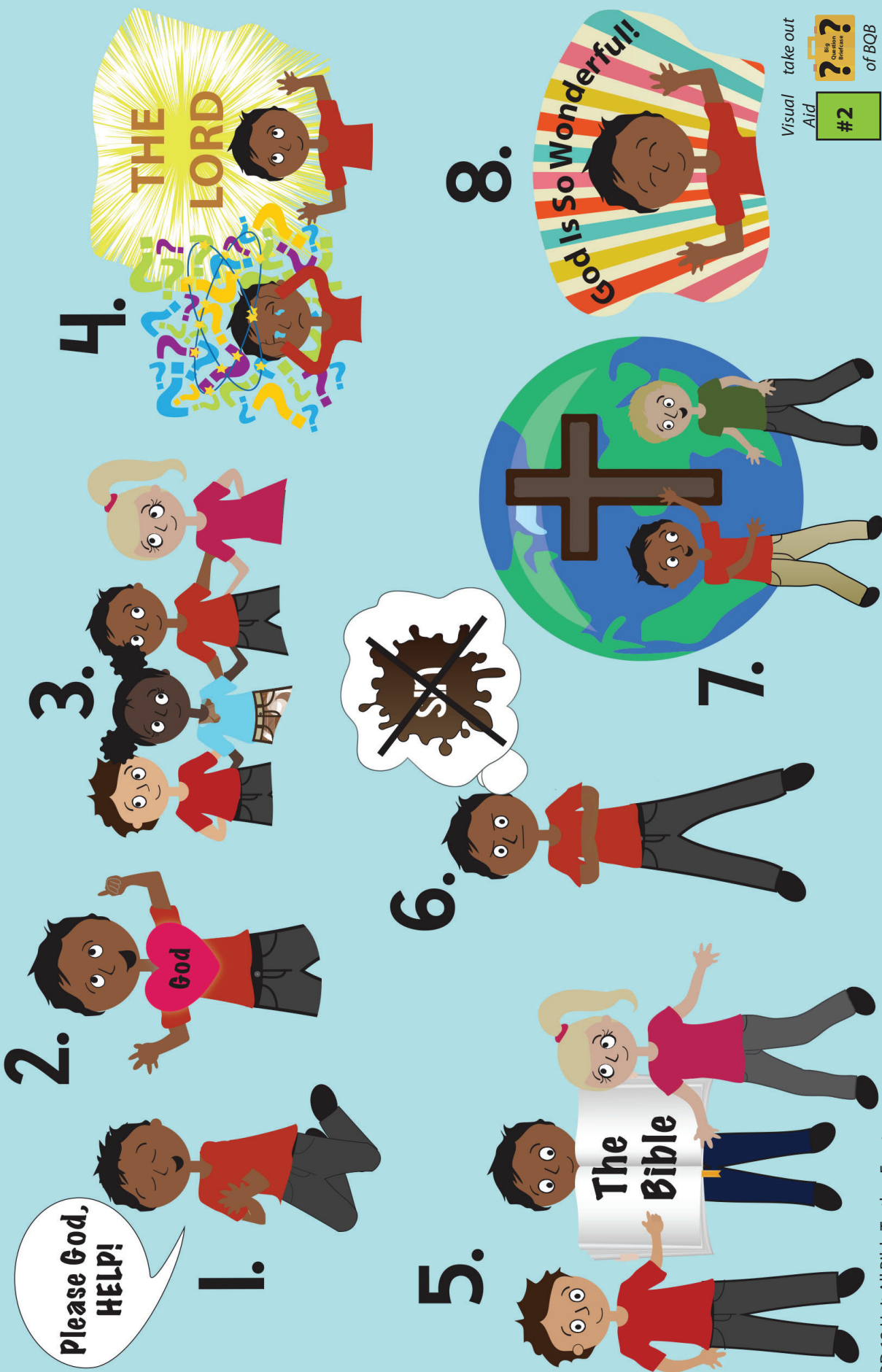

Visual take out  
Aid #2



## **This Unit's Bible Truths**

"They Should Live Like Jesus" is a good beginning, but there's so more to learn. So it's time for us to dig down even deeper for more answers to our Big Question about God. We're going to be learning EIGHT Bible truths that all tell us more about how God wants His people to live.

Who would like to hand me the picture with our eight Bible truths on it? It's in the Big Question Box/Briefcase."

*Choose a child to get it and hand it to you, then hold it up and show them the pictures of the eight truths they will be learning.*

*After everyone has had a good look say...*

"Ok, we've learned five truths about how to live for God. They are: "By Asking God for His Help," "By Loving God Most of All," "By Loving Other People As God Has Loved Them," "By Trusting God and Being Happy with What He Wants," and "By Learning God's Word and Obeying It" (point to pictures as you identify each Bible Truth). Now let's look at our Bible Truth Clue sign and see if we can figure out which of these eight truths we will be learning about today. Who would like to get it out of the Big Question Briefcase for me?"

*Choose a child to open the briefcase, take out the Bible Truth Clue sign and hand it to you.*

CAN YOU GUESS BIBLE TRUTH 6?

**How Should God's People Live?  
They Should Live Like Jesus...**

**By Saying "???"  
to Disobeying God!**

**HINT:** What is the opposite  
of "yes"? It starts with an "n"  
and it rhymes with "go."

**ANSWER:**  
**By Saying "NO"  
to Disobeying God!**

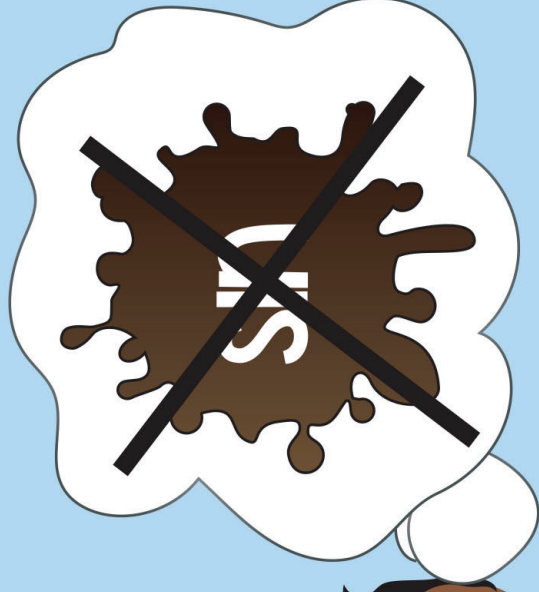

Visual  
Aid

take out



#3

of BOB

# Revealing the Bible Truth

## We Are Learning

*Hold up the front side for the children to see. Cover up the answer, written along the bottom, and say:*

**“How Should God’s People Live?  
They Should Live Like Jesus!  
By Saying “????” to Disobeying God!”**

We’re missing one word. Here’s the hint to what the missing word is. It says: “What is the opposite of “yes”? It starts with an “N” and it rhymes with “go.”

Can you guess? It’s “NO!”

So, the Bible Truth we are learning today is:

*(uncover answer from bottom of sign, show it to them and say:)*

**“How Should God’s People Live?  
They Should Live Like Jesus!  
By Saying “NO” to Disobeying God!”**

And here is what this Bible Truth means:  
*(read the meaning off of the back of the sign, say:)*

Jesus is the perfect Son of God, but when He lived on earth, He was tempted to disobey God just as we are. Sometimes, God’s plan for Jesus was very hard. Jesus was tempted disobey God, His Father, and do something easier. God’s enemy, Satan, knew just what kinds of things to tempt Jesus with. Oh, how he wanted Jesus to disobey God! He did NOT want Jesus to be our Savior!

But no matter what the temptation was, Jesus always said “no” to it. He prayed to God, His Father, to help Him. He remembered God’s Word and it made Him strong to always say “no” to disobeying God. He never, ever disobeyed God, so He could be our perfect Savior.

God’s people are often tempted to disobey God, too. They want to love God. They want to obey Him. They have the Holy Spirit living in their hearts, helping them; but (unlike Jesus), sin is very strong in their hearts, too.

God wants His people to do what Jesus did when they are tempted. He wants them to pray to Him and ask for His help. He wants them to remember His Word, the Bible. His Holy Spirit living in their hearts can help them say “no” to sin. And when they do give in to temptation, His Holy Spirit can comfort them with God’s forgiveness.

When we turn away from our sins and trust in Jesus as our Savior, God promises to help us say “no” to disobeying God, too. And, He promises to forgive our sins, even when we do disobey Him. Thank You, God!

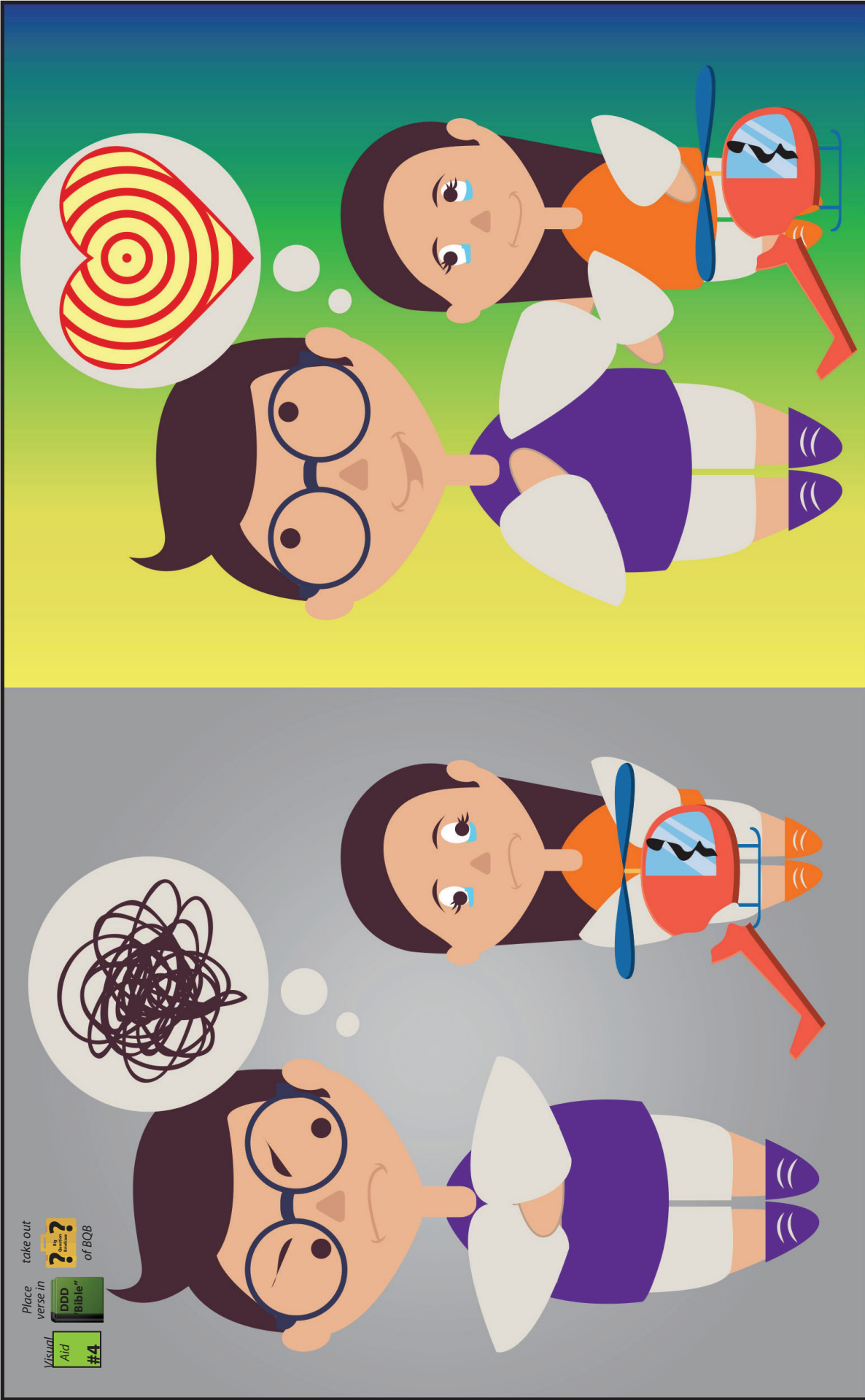

**“No temptation has overtaken you that is not common to man. God is faithful, and he will not let you be tempted beyond your ability, but with the temptation he will also provide the way of escape, that you may be able to endure it.” -- 1 Corinthians 10:13, ESV**

## Bible Truth 6 Bible Verse

*Remove the Bible Verse Picture from the "Bible" folder and hold it up for all the children to see, then say:*

1 Corinthians 10:13 tells us:

### **1 Corinthians 10:13:**

"No temptation has overtaken you that is not common to man. God is faithful, and he will not let you be tempted beyond your ability, but with the temptation he will also provide the way of escape, that you may be able to endure it."

### **Learn a Little:**

"God is faithful, and he will not let you be tempted beyond your ability."

### **What does that mean?**

God's people will face temptations to sin every day. Their temptations are common to man--that is, they will be tempted to sin against God, just like everyone else. But, God's people can be encouraged that God is always there to help them say "no." He promises that He will never let them be tempted more than they can bear. With any temptation they face, He promises to be with them. He promises to provide a way of escape, so they can endure the temptation without sinning. But even though God promises to always provide a way out of temptation, God's people still many times give in to temptation. They do not wait for God's way out. They choose to disobey Him. But even when they do, they turn to Him and ask His forgiveness. And thanks to their Savior, Jesus, God always does forgive them. How good, merciful and powerful is the Lord! We can be God's people when we turn away from our sins and trust in Jesus as our Savior.

"We've said our Bible verse, now let's sing it!"

## No Temptation:

### 1 Corinthians 10:13

*DDD ESV Songs 12, track 38*

No temptation has overtaken you,  
That is not,  
Common to man,  
God is faithful,  
He will not let you be,  
Tempted beyond,  
Your ability,  
But with the temptation  
He will also provide,  
The way of escape,  
So that you might be able to endure it.  
First Corinthians Chapter Ten,  
verse thirteen.

"Now it's time to do a bit more deep down investigating. Let's see what Detective Dan wants us to help him figure out. Would someone like to get it out for me?"

take out



Place in



Visual Aid

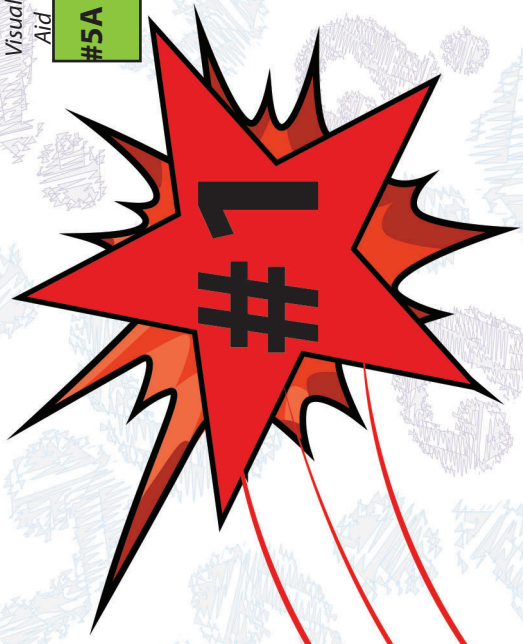

# Detective Dan's Listening Assignment #1

# Detective Dan's

## Listening Assignment #1



Hi, Deep Down Detectives!

I'm working on a brand-new case called:

“The Case of the Escape that Waited.”

I need to find out:

1. Who needed to escape? Who did he need to escape from?

AND

2. How could he have escaped? Why did he wait?

Can you help me? Listen carefully to the story and you might just hear the answers!

Thanks!

Detective Dan

***Then say,*** “Ok, Deep Down Detectives! Put on your best listening ears and see if you can hear the answers to Detective Dan's questions. When I finish telling the story, we will see if we can answer all of his questions.”

*Read the Bible Truth story, putting up the storyboard pictures as you tell it.*

*At the end of the story, repeat the questions and lead the children in answering them. Present the gospel and close in prayer.*

\*Answers to assignment questions, the gospel and ACTS prayer are also included at the end of the story text.\*

Answers:

**1. Who needed to escape? Who did he need to escape from and why?**

David needed to escape from King Saul. Saul was jealous and wanted to kill David.

**2. How could he have escaped? Why did he wait? Why did he wait?** David could have killed Saul, but he knew that was wrong. He chose to wait for the LORD to rescue him, in His perfect timing.

**For You and Me:**

David waited a long time for God to provide his escape from King Saul. How hard it must have been to wait! But God helped David wait. He helped him say ‘no’ to the temptation to get rid of King Saul his own way. And how God blessed David when he waited for the LORD's perfect timing! Maybe we will never have someone chasing after us and trying to kill us like David did. Maybe we will never be tempted to kill anybody like he was. But we have plenty of other temptations that come our way. Every day brings its own set of temptations to disobey God and His good ways. The LORD helped David and He can help us. He can help us turn away and trust in Jesus as our Savior. This is how we become God's people. And, He can help us to keep on saying ‘no’ to disobeying Him and to keep on living His good way, instead of giving in to sin.



take out



of BQB

Place in



Visual Aid



# Detective Dan's Listening Assignment #2

# Detective Dan's

## Listening Assignment #2



Hi, Deep Down Detectives!

I'm still working on the case called:

"The Case of the Escape that Waited."

Our Bible verse is 1 Corinthians 10:13, ESV:

"No temptation has overtaken you that is not common to man. God is faithful, and he will not let you be tempted beyond your ability, but with the temptation he will also provide the way of escape, that you may be able to endure it."

I need to find out:

1. Who was tempted to disobey God? How?

AND

2. How did God help him and provide him a way out?

Can you help me? Listen carefully to the story and you might just hear the answers!

Thanks for your help!

Detective Dan

**Then say,** "Ok, Deep Down Detectives! Put on your best listening ears and see if you can hear the answers to Detective Dan's questions. When I finish telling the story, we will see if we can answer all of his questions."

*Read the Bible Truth story, putting up the storyboard pictures as you tell it. At the end of the story, repeat the questions and lead the children in answering them.*

*Present the gospel and close in prayer.*

\*Answers to assignment questions, the gospel and ACTS prayer are also included at the end of the story text.\*

Answers:

**Our Bible Verse is: 1 Corinthians 10:13, ESV:**

"No temptation has overtaken you that is not common to man. God is faithful, and he will not let you be tempted beyond your ability, but with the temptation he will also provide the way of escape, that you may be able to endure it."

**1. Who was tempted to disobey God? How?** David was. He was tempted to get rid of King Saul his own way.

**2. How did God help him and provide him a way out?** God helped him say 'no' to temptation. He helped David wait and trust. And in His perfect timing, God, Himself, provided the way out from King Saul.

**For You and Me:**

David waited a long time for God to provide his escape from King Saul. How hard it must have been told wait! But God helped David wait. He helped him say 'no' to the temptation to get rid of King Saul his own way. And how God blessed David when he waited for the LORD's perfect timing! Maybe we will never have someone chasing after us and trying to kill us like David did. Maybe we will never be tempted to kill anybody like he was. But we have plenty of other temptations that come our way. Every day brings its own set of temptations to disobey God and His good ways. The LORD helped David and He can help us. He can help us turn away and trust in Jesus as our Savior. This is how we become God's people. And, He can help us to keep on saying 'no' to disobeying Him and to keep on living His good way, instead of giving in to sin.

take out



Place in



Visual Aid

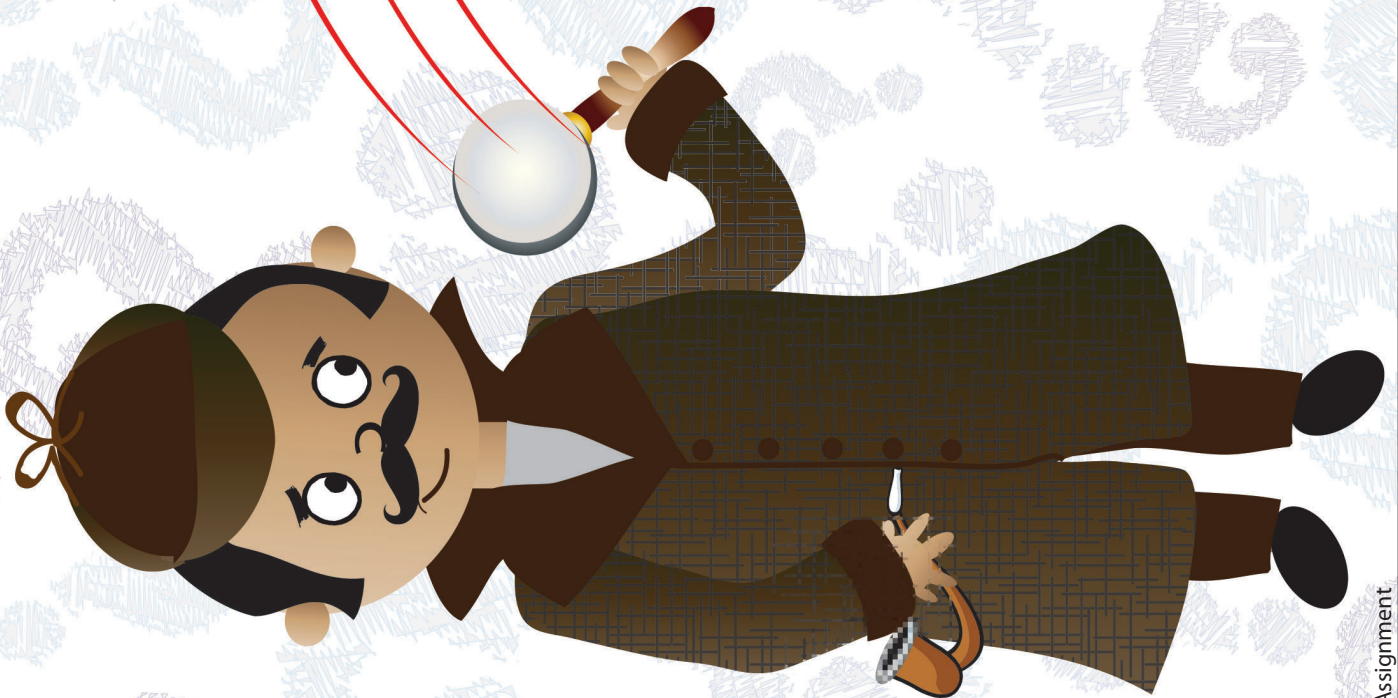

# Detective Dan's Listening Assignment #3

# Detective Dan's

## Listening Assignment #3



Hi, Deep Down Detectives!

I'm still working on the case called:

"The Case of the Escape that Waited."

I found SIX clues, but TWO of them are NOT in the story. They are: a harp, a rabbit, Goliath, a water jar, a pumpkin, and a spear.

*Hold up each of the six pictures for the children to see as you identify them. Better yet, put them up on your flannelgraph board, off to one side.*

I need to know:

1. Which four belong in the story and which two don't?
2. Who kept asking God for help to can you say no keep saying no to temptation? How did God answer his prayers?

Can you help me? Listen carefully to the story and you might just hear the answers!

Thanks!

Detective Dan

**Then say,** "Ok, Deep Down Detectives! Put on your best listening ears and see if you can hear the answers to Detective Dan's questions. When I finish telling the story, we will see if we can answer all of his questions."

*Read the Bible Truth story, putting up the storyboard pictures as you tell it. At the end of the story, repeat the questions and lead the children in answering them. Present the gospel and close in prayer.*

\*Answers to assignment questions, the gospel and ACTS prayer are also included at the end of the story text.\*

Answers:

1. Which four belong in the story and which two don't?  
The harp, Goliath, the water jar and the spear belong. The rabbit and the pumpkin do not.
2. Who kept asking God for help to can you say no keep saying no to temptation? How did God answer his prayers? David did. God helped David wait and trust. And in His perfect timing, God, Himself, provided the way out from King Saul.

**For You and Me:**

David waited a long time for God to provide his escape from King Saul. How hard it must have been told wait! But God helped David wait. He helped him say 'no' to the temptation to get rid of King Saul his own way. And how God blessed David when he waited for the LORD's perfect timing! Maybe we will never have someone chasing after us and trying to kill us like David did. Maybe we will never be tempted to kill anybody like he was. But we have plenty of other temptations that come our way. Every day brings its own set of temptations to disobey God and His good ways. The LORD helped David and He can help us. He can help us turn away and trust in Jesus as our Savior. This is how we become God's people. And, He can help us to keep on saying 'no' to disobeying Him and to keep on living His good way, instead of giving in to sin.

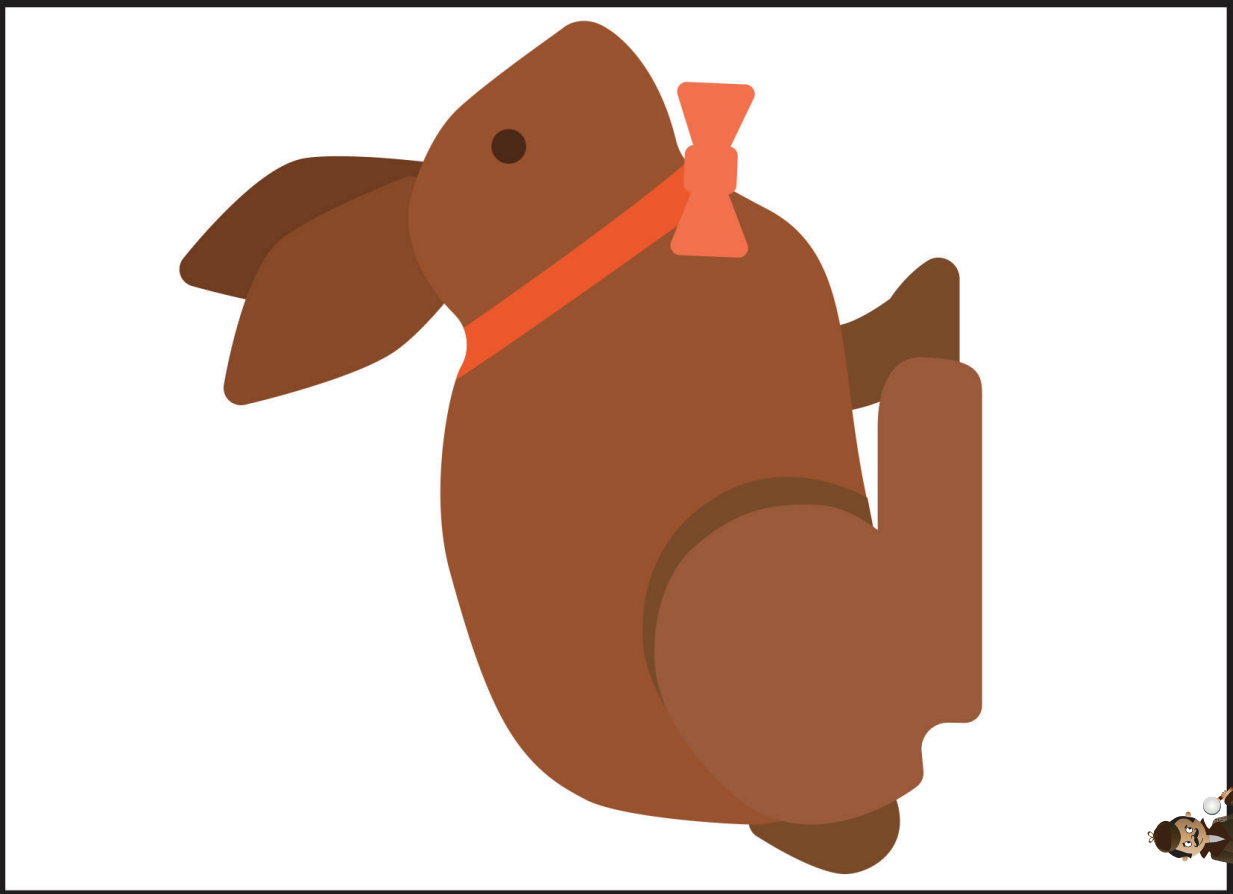

A Rabbit

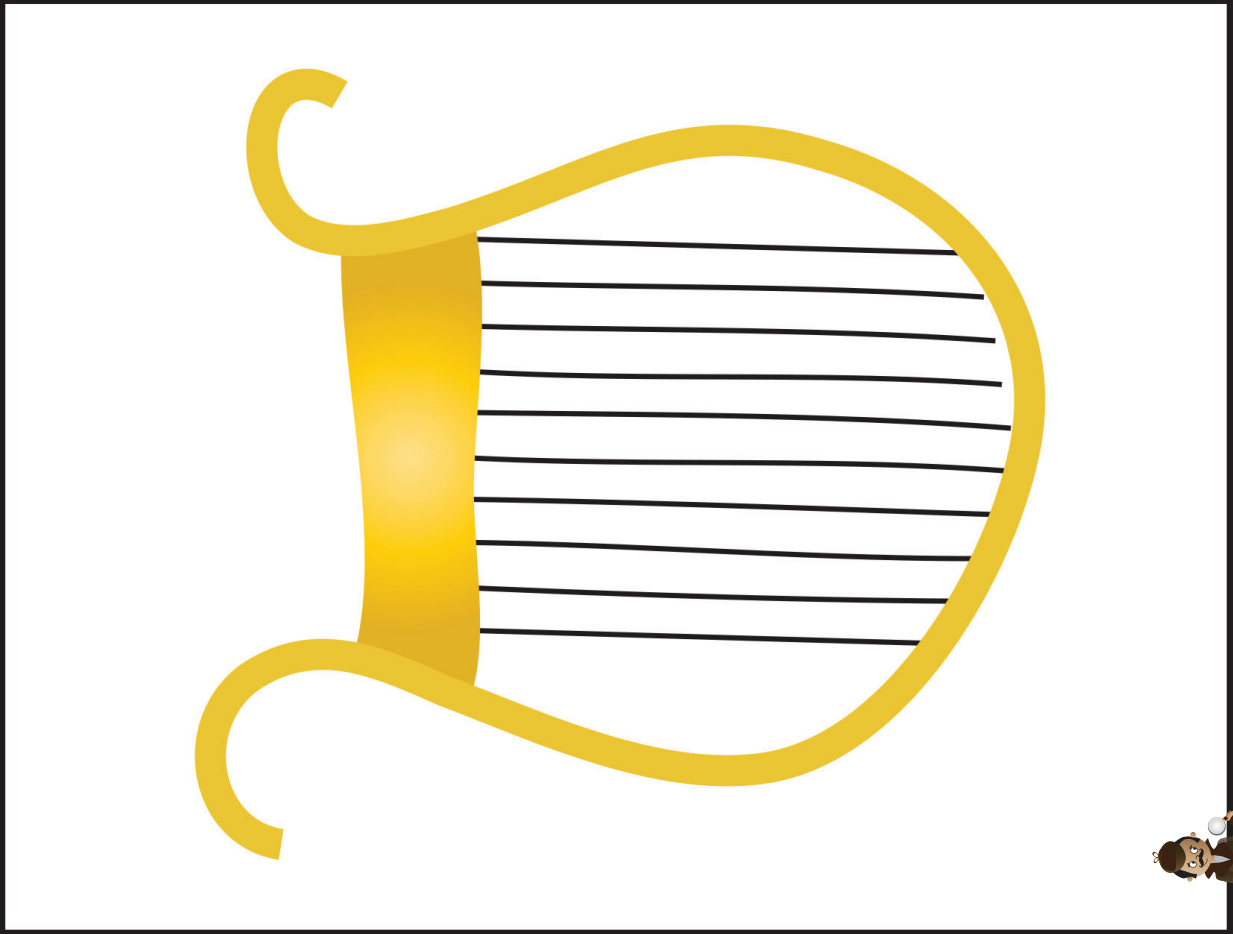

A Harp

VISUAL  
AID  
#5C

Place in  
DDD  
Bible™

take out  
Big  
Question  
Briefcase  
of BQB

DDD 12.6 Lesson 3 Listening Assignment Clue Picture 2 for kids

VISUAL  
AID  
#5C

Place in  
DDD  
Bible™

take out  
Big  
Question  
Briefcase  
of BQB

DDD 12.6 Lesson 3 Listening Assignment Clue Picture 1 for kids

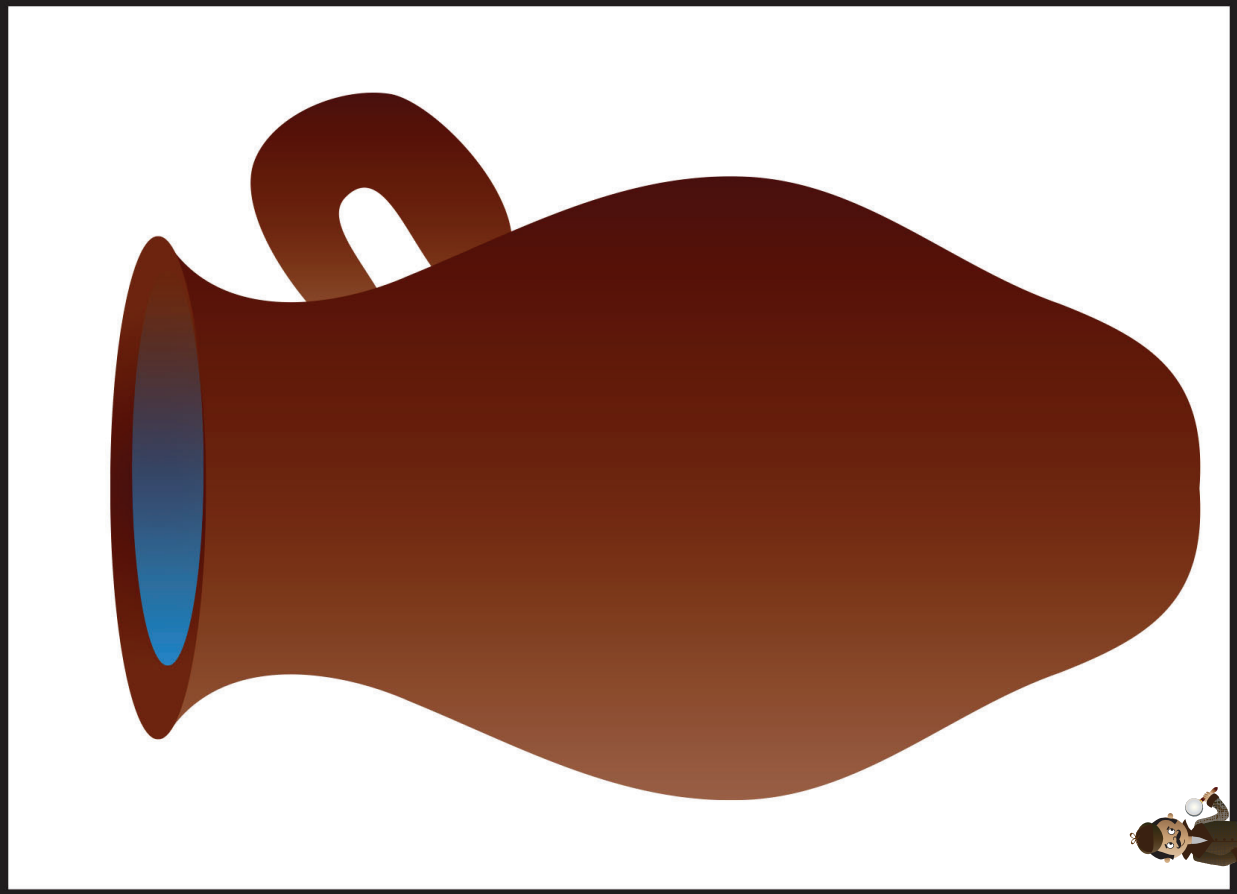

A Water Jar



A Giant Named Goliath

VISUAL  
AID  
#5C

Place in  
DDD  
Bible™

take out  
Big  
Question  
Briefcase  
of BQB

VISUAL  
AID  
#5C

Place in  
DDD  
Bible™

take out  
Big  
Question  
Briefcase  
of BQB

DDD 12.6 Lesson 3 Listening Assignment Clue Picture 4 for kids

DDD 12.6 Lesson 3 Listening Assignment Clue Picture 3 for kids



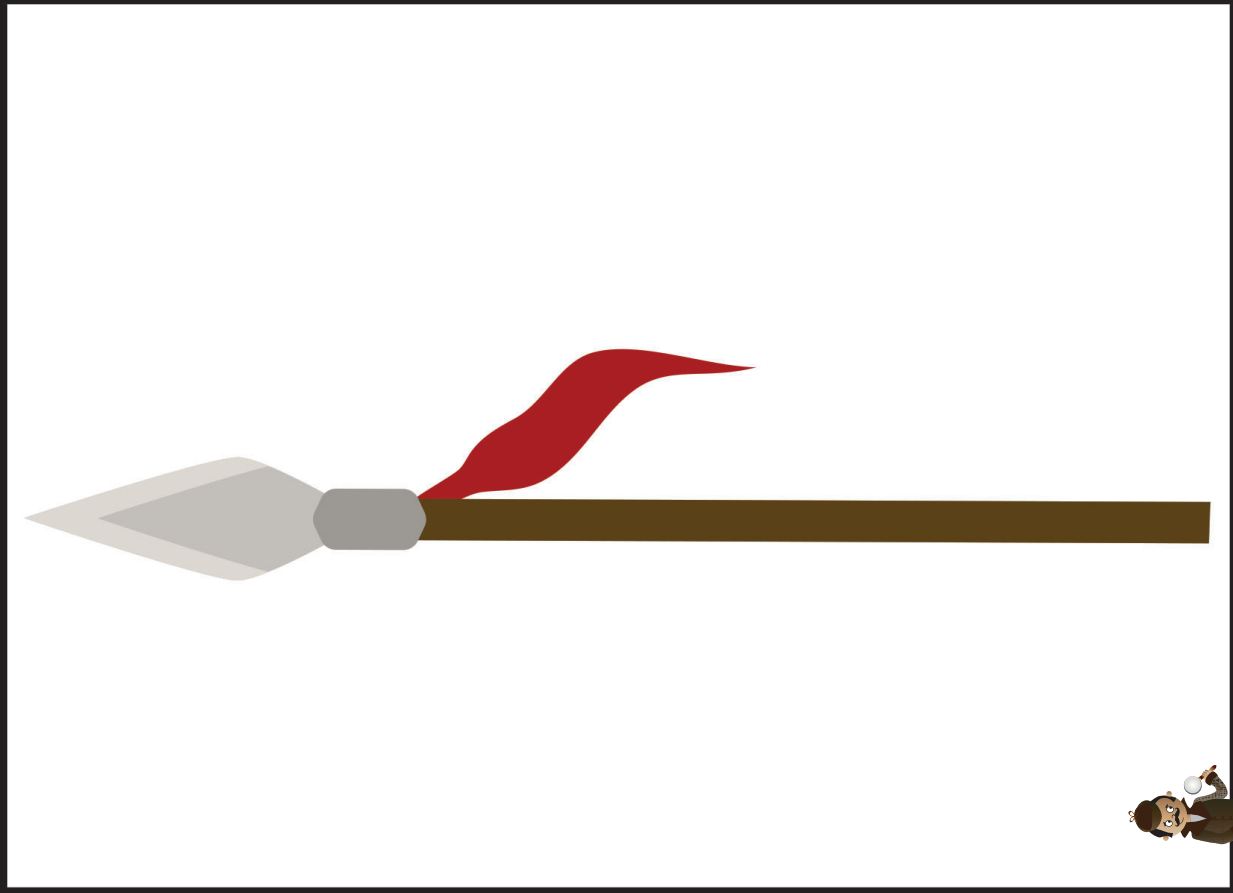

A Spear

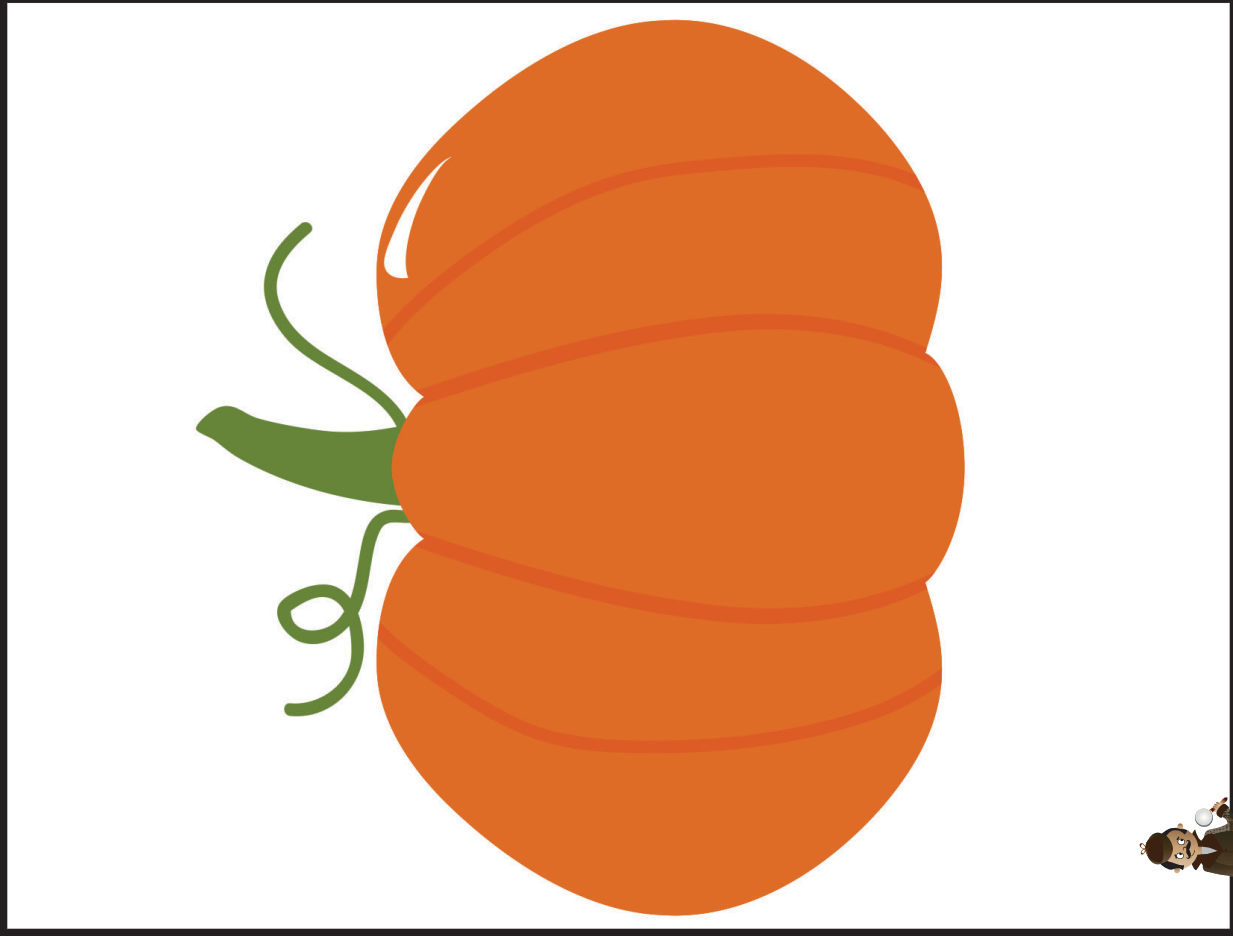

A Pumpkin

VISUAL  
AID  
#5C

Place in  
DDD  
Bible™

take out  
Big  
Question  
Briefcase  
of BQB

VISUAL  
AID  
#5C

Place in  
DDD  
Bible™

take out  
Big  
Question  
Briefcase  
of BQB

DDD 12.6 Lesson 3 Listening Assignment Clue Picture 6 for kids

DDD 12.6 Lesson 3 Listening Assignment Clue Picture 5 for

# “The Case of the Escape that Waited” | Samuel 17:19,23-24,27,31; 2 Samuel 5-6

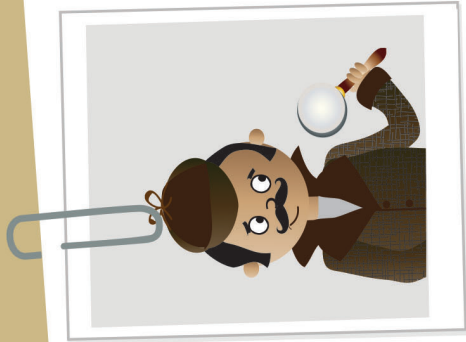

## Detective Dan's Listening Assignment #1

1. Who needed to escape? Who did he need to escape from and why?
2. How could he have escaped? Why did he wait?



## Detective Dan's Listening Assignment #2

### 1 Corinthians 10:13, ESV

“No temptation has overtaken you that is not common to man. God is faithful, and he will not let you be tempted beyond your ability, but with the temptation he will also provide the way of escape, that you may be able to endure it.”

1. Who was tempted to disobey God? How?
2. How did God help him and provide him a way out?

(more listening and discussion questions are included in the curriculum at [praisefactory.org](http://praisefactory.org))

**I. David was quite a man! He was a good shepherd who protected his sheep.**



I. David was quite a man! He was a good shepherd who protected his sheep.

**2. He was a brave fighter who fought off enemies, whether they were great giants like Goliath, or even whole armies.**



2. He was a brave fighter who fought off enemies, whether they were great giants like Goliath, or even whole armies.

**3. He sang and played the harp, making up beautiful songs for God.**





3. He sang and played the harp, making up beautiful songs for God.

**4. But most of all, David was a man after God's own heart.**

**What does it mean to be a man after God's own heart? Well, it means that David loved God and wanted to obey Him, even when it was very tempting to disobey Him.**

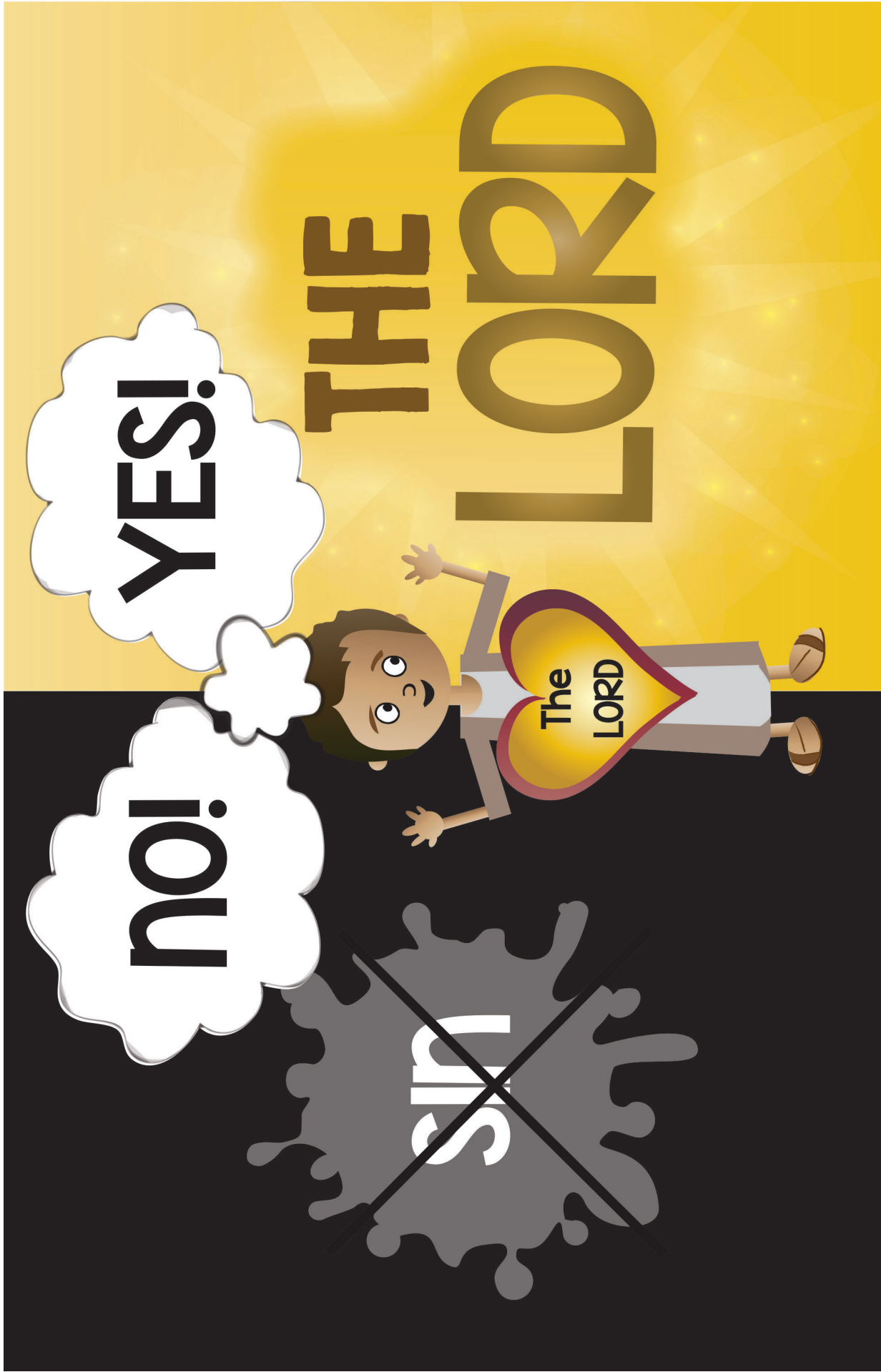

4. But most of all, David was a man after God's own heart. What does it mean to be a man after God's own heart? Well, it means that David loved God and wanted to obey Him, even when it was very tempting to disobey Him.

**5. David's people, the people of Israel, loved David!**

**They were proud of how he protected his sheep from fierce, wild animals, like lions and bears. They praised David for being such a brave fighter who fought off their powerful enemies. They loved David's songs and sang them to God.**

**They were glad that David was a man after God's own heart: a man who loved God and wanted to obey Him, even when it was very tempting to disobey Him. They could see that God was pleased with David, too. God helped David in many special ways.**



5. David's people, the people of Israel, loved David! They were proud of how he protected his sheep from fierce, wild animals, like lions and bears. They praised David for being such a brave fighter who fought off their powerful enemies. They loved David's songs and sang them to God. They were glad that David was a man after God's own heart: a man who loved God and wanted to obey Him, even when it was very tempting to disobey Him. They could see that God was pleased with David, too. God helped David in many special ways.

**6. Yes, it seemed that EVERYONE in Israel loved David. But that was not quite true.**

**There was one man among the people of Israel who certainly did NOT love David. Who was this man? It was none other than Saul, the king of Israel!**

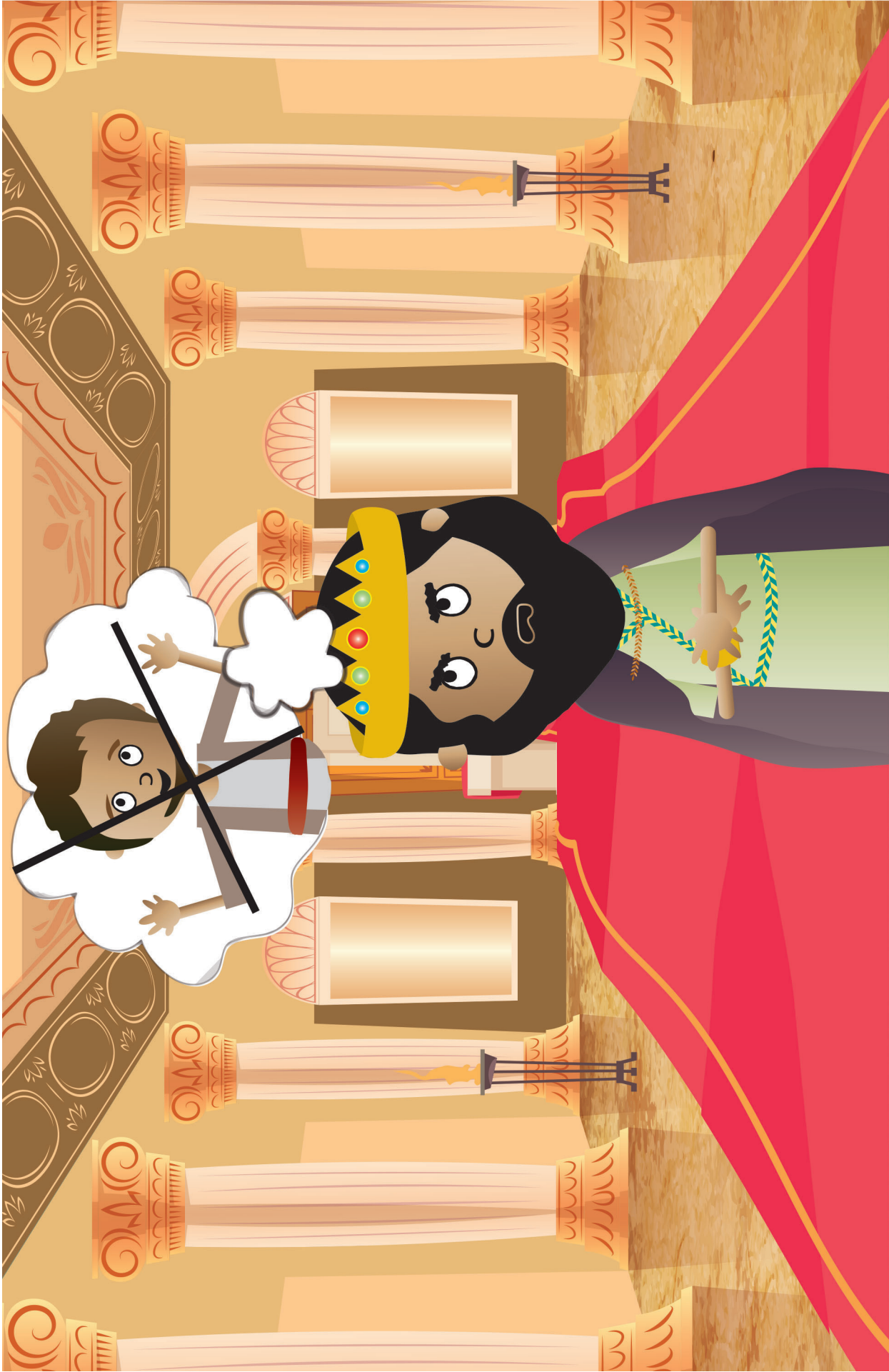

6. Yes, it seemed that **EVERYONE** in Israel loved David. But that was not quite true. There was one man among the people of Israel who certainly did **NOT** love David. Who was this man? It was none other than Saul, the king of Israel!

**7. Yes, King Saul disliked David because he was jealous of him. (Jealous means wishing you had what someone else has.)**

**Saul's jealousy of David grew bigger and bigger until it turned into anger and hate. David seemed to have everything that HE used to have, and Saul hated that.**

**Before David came, who did the people praise? They had praised HIM, King Saul. They praised HIM for being a brave fighter and for being Israel's first king. They praised HIM as the man God helped in special ways. And, oh, how King Saul loved the people's praise!**





7. Yes, King Saul disliked David because he was jealous of him. (Jealous means wishing you had what someone else has.) Saul's jealousy of David grew bigger and bigger until it turned into anger and hate. David seemed to have everything that HE used to have, and Saul hated that. Before David came, who did the people praise? They had praised HIM, King Saul! They praised HIM for being a brave fighter and for being Israel's first king. They praised HIM as the man God helped in special ways. And, oh, how King Saul loved the people's praise!

**8. But now, all that had changed. When Saul had been tempted to disobey God, he didn't say "no." He said "yes"! Saul chose to sin against God and His good ways over and over.**

**God warned Saul many times to turn away from disobeying Him. But what do you think Saul did? Saul kept on disobeying God. How sad!**



8. But now, all that had changed. When Saul had been tempted to disobey God, he didn't say "no." He said "yes"! Saul chose to sin against God and His good ways over and over. God warned Saul many times to turn away from disobeying Him. But what do you think Saul did? Saul kept on disobeying God. How sad!

**9. So, at last, after disobeying God over and over and over, the prophet Samuel came to Saul with some very sad news.**

**“The LORD says, ‘Because you have chosen to keep on disobeying Me, I’m going to make David and his sons the kings over Israel, instead of your family. No longer will you receive the special help I give my kings. Those days are gone for you,’” Samuel told Saul.**



Q. So, at last, after disobeying God over and over and over, the prophet Samuel came to Saul with some very sad news. "The LORD says, 'Because you have chosen to keep on disobeying Me, I'm going to make David and his sons the kings over Israel, instead of your family. No longer will you receive the special help I give My kings. Those days are gone for you.'" Samuel told Saul.

**10. This made King Saul even MORE jealous! Now, he hated David even more.**

**Saul would NOT let David be king. He would get rid of David! He would make sure HIS family, not David's, would be the kings over Israel! King Saul decided to kill David. He threw a long spear at him. Oh, no!**

**Did Saul hit David? No, he did not! God protected David and he got away!**



10. This made King Saul even MORE jealous! Now, he hated David even more. Saul would NOT let David be king. He would get rid of David! He would make sure HIS family, not David's, would be the kings over Israel! King Saul decided to kill David. He threw a long spear at him. Oh, no! Did Saul hit David? No, he did not! God protected David and he got away!

**II. Next, King Saul sent men to get rid of David as he slept. Oh, no!**

**Did the men get David? No, they did not! God protected David. David's wife, Michal, helped David escape.**



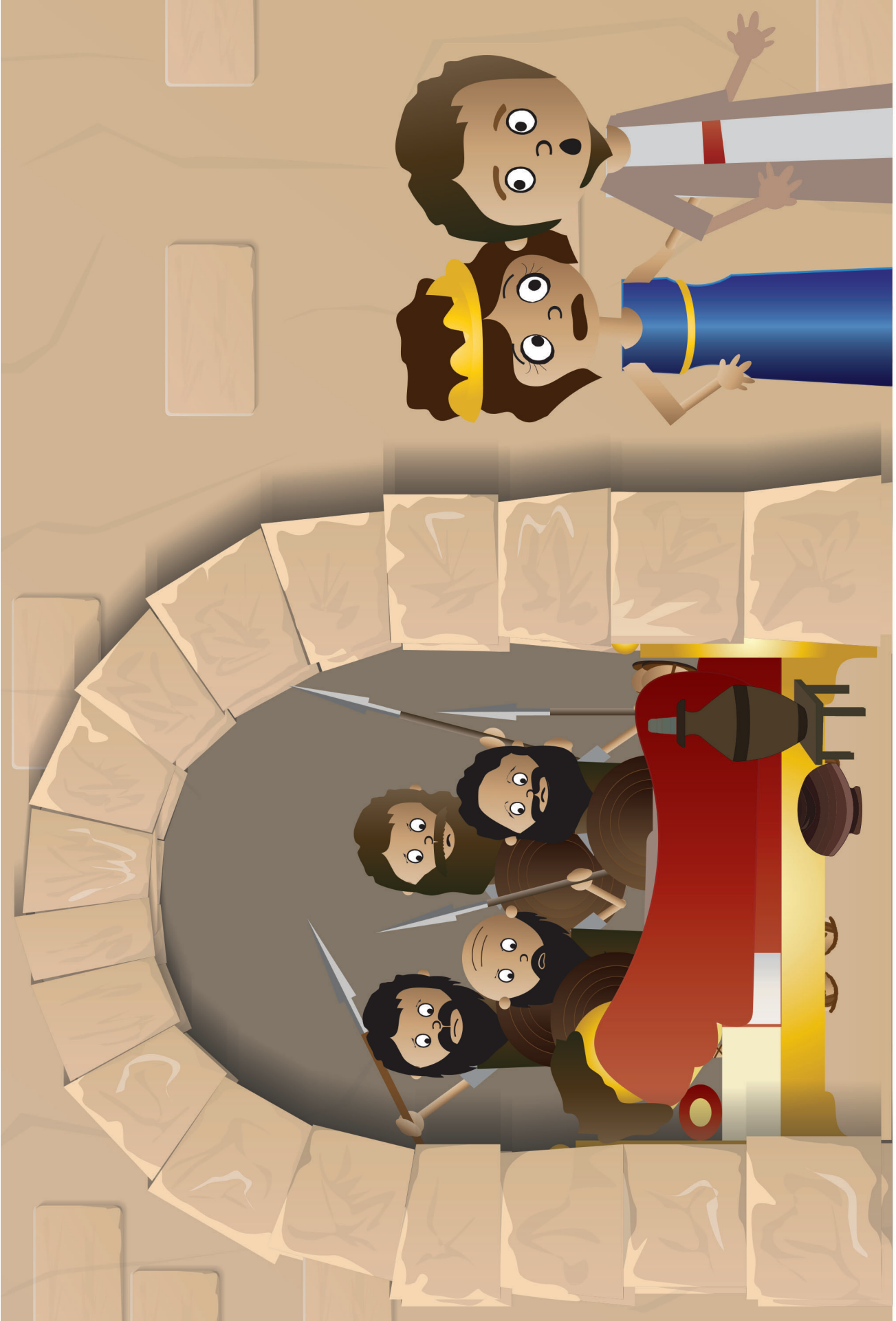

**II. Next, King Saul sent men to get rid of David as he slept. Oh, no! Did the men get David? No, they did not! God protected David. David's wife, Michal, helped David escape.**

**12. Now David knew he was not safe anywhere near King Saul. There was only one thing he could do. He must run far, far away.**

**So, away from the king's palace, away from the cities, and out into the dry, desert-y wilderness, David ran. He ran away to where no one lived. Surely, King Saul would give up and leave David alone out there.**

**But King Saul did NOT! He was determined to get rid of David! So, King Saul and his soldiers went out into that dry, desert-y wilderness hunting for David. Nothing would stop King Saul from getting rid of David!**



12. Now David knew he was not safe anywhere near King Saul. There was only one thing he could do. He must run far, far away. So, away from the king's palace, away from the cities, and out into the dry, desert-y wilderness, David ran. He ran away to where no one lived. Surely, King Saul would give up and leave David alone out there. But King Saul did NOT! He was determined to get rid of David! So, King Saul and his soldiers went out into that dry, desert-y wilderness hunting for David. Nothing would stop King Saul from getting rid of David!

**13. What a hard life David lived! Every day, Saul and his soldiers were after him. He was always on the run. “Run, David, run! Hide, David, hide!”**

**Where would David make his home? Where would he sleep? David had no home. He slept on the ground, or sometimes in a cave. David couldn't rest anywhere for long. Saul and his soldiers were never far behind. David had to keep moving and stay alert!**

**And where in that big, dry, desert-y wilderness could David find food and water? It wasn't easy. Sometimes, there were only hoppy bugs like locusts to eat! Wriggle, wriggle! Crunch, crunch! Ugh!**



13. What a hard life David lived! Every day, Saul and his soldiers were after him. He was always on the run. "Run, David, run! Hide, David, hide!" Where would David make his home? Where would he sleep? David had no home. He slept on the ground, or sometimes in a cave. David couldn't rest anywhere for long. Saul and his soldiers were never far behind. David had to keep moving and stay alert! And where in that big, dry, desert-y wilderness could David find food and water? It wasn't easy. Sometimes, there were only hoppy bugs like locusts to eat! Wriggle, wriggle! Crunch, crunch! Ugh!

**14. God had once called David a man after His own heart, a man who loved God and wanted to obey Him.**

**But NOW what David was thinking inside his heart, with King Saul after him, day after day after day? Did he STILL love God and want to obey Him?**

**David knew that the LORD didn't want him to hate Saul or hurt him. But, oh, it must have been very tempting to want to both hate and hurt Saul after all he had done.**



14. God had once called David a man after His own heart, a man who loved God and wanted to obey Him. But NOW what David was thinking inside his heart, with King Saul after him, day after day after day? Did he STILL love God and want to obey Him? David knew that the LORD didn't want him to hate Saul or hurt him. But, oh, it must have been very tempting to want to both hate and hurt Saul after all he had done.

**15. And what would happen if David DID get a chance to kill Saul? Would he keep saying “no” to disobeying God, or would he kill Saul and be rid of him, once and for all? David was soon to find out.**

**One night, David and his soldier friend, Abishai, found the place where King Saul and his soldiers were sleeping. They tip-toed around all the sleeping soldiers until they came to King Saul, himself.**





15. And what would happen if David DID get a chance to kill Saul? Would he keep saying “no” to disobeying God, or would he kill Saul and be rid of him, once and for all? David was soon to find out. One night, David and his soldier friend, Abishai, found the place where King Saul and his soldiers were sleeping. They tip-toed around all the sleeping soldiers until they came to King Saul, himself.

**16. Right next to King Saul's head were a water jar and a big spear. Tempting thoughts came into David's heart. He could use the water jar to hit Saul on the head and hurt him. He could use the spear and even kill Saul.**

**What would David do now? How mean Saul had been to him! How tired David was of running away from Saul! This would be an easy way for David to finally get rid of Saul.**

**Abishai agreed with those tempting thoughts. "Let's get rid of King Saul," Abishai urged David. David picked up the water jar and the spear. What would he do with them next?**



16. Right next to King Saul's head were a water jar and a big spear. Tempting thoughts came into David's heart. He could use the water jar to hit Saul on the head and hurt him. He could use the spear and even kill Saul. What would David do now? How mean Saul had been to him! How tired David was of running away from Saul! This would be an easy way for David to finally get rid of Saul. Abishai agreed with those tempting thoughts. "Let's get rid of King Saul," Abishai urged David. David picked up the water jar and the spear. What would he do with them next?

**17. The LORD helped David NOT give into the temptation to disobey Him and hurt Saul.**



17. The LORD helped David NOT give into the temptation to disobey Him and hurt Saul.

**18. With jar and spear in hand, David led Abishai away from the camp. When they were a safe distance away from the Saul and his soldiers, David woke them up with a shout.**

**“King Saul, here are your water jar and your spear. I could have killed you with them, but I did not,” David yelled. “Send a man here to me and I will give them back to you. But please, turn away from trying to kill me. I have done nothing to you.”**



18. With jar and spear in hand, David led Abishai away from the camp. When they were a safe distance away from the Saul and his soldiers, David woke them up with a shout. "King Saul, here are your water jar and your spear. I could have killed you with them, but I didn't;" David yelled. "Send a man here to me and I will give them back to you. But please, stop trying to kill me. I've done nothing to you," David pleaded.

**19. At last, that perfect timing did come. Saul died, and David's days of running were over. NOW, what was David thinking in his heart? Would he celebrate that Saul was dead? It would be tempting to be happy about that.**

**But David said "no" to that temptation, too. David was sad for Saul. He even taught the people a special song to honor him at his funeral.**





19. At last, that perfect timing did come. Saul died, and David's days of running were over. NOW, what was David thinking in his heart? Would he celebrate that Saul was dead? It would be tempting to be happy about that. But David said "no" to that temptation, too. David was sad for Saul. He even taught the people a special song to honor him at his funeral.

**20. And not long after Saul died, the people of Israel made David their king.**

**Everyone celebrated with fig cakes and roast meat. They sang songs of praise to the LORD and set up His special meeting place in Jerusalem near David's palace.**

**And who led the people in praising the LORD that day? Why, it was King David, himself! He wanted all the people to be people after God's own heart: people who loved God and wanted to obey Him, even when it was very hard.**



20. And not long after Saul died, the people of Israel made David their king. Everyone celebrated with fig cakes and roast meat. They sang songs of praise to the LORD and set up His special meeting place in Jerusalem near David's palace. And who led the people in praising the LORD that day? Why, it was King David, himself! He wanted all the people to be people after God's own heart: people who loved God and wanted to obey Him, even when it was very hard.

## DDD 12.6 Simple Story Scenes

# “The Case of the Escape that Waited” | Samuel 17:19,23-24,27,31; 2 Samuel 5-6

## SOLVED

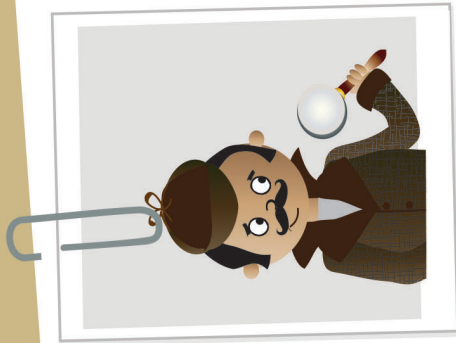

### Detective Dan's Listening Assignment #1

1. Who needed to escape? Who did he need to escape from and why? David needed to escape from King Saul. Saul was jealous and wanted to kill David.
2. How could he have escaped? Why did he wait? David could have killed Saul, but he knew that was wrong. He chose to wait for the LORD to rescue him, in His perfect timing.

#### For You and Me:

David waited a long time for God to provide his escape from King Saul. How hard it must have been to wait! God helped David wait. He helped him say 'no' to the temptation to get rid of King Saul his own way. And how God blessed David when he waited for His perfect timing! Maybe we will never have someone chasing us and trying to kill us, like David did. Maybe we will never be tempted to kill anybody, like he was. But we have plenty of other temptations that come our way. Every day brings its own set of temptations to disobey God and His good ways. God helped David and He can help us. He can help us turn away and trust in Jesus as our Savior. This is how we become God's people. And, He can help us to keep on saying 'no' to disobeying Him and to keep on living His good way, instead of giving in to sin.

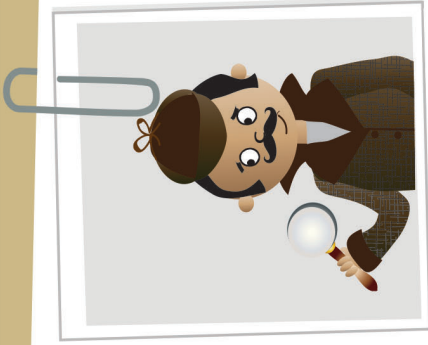

### Detective Dan's Listening Assignment #2

1 Corinthians 10:13, ESV

“No temptation has overtaken you that is not common to man. God is faithful, and he will not let you be tempted beyond your ability, but with the temptation he will also provide the way of escape, that you may be able to endure it.”

1. Who was tempted to disobey God? How? David was. He was tempted to get rid of King Saul his own way.
2. How did God help him and provide him a way out? God helped him say 'no' to temptation. He helped David wait and trust. And in His perfect timing, God, Himself, provided the way out from King Saul.

#### For You and Me:

David waited a long time for God to provide his escape from King Saul. How hard it must have been to wait! God helped David wait. He helped him say 'no' to the temptation to get rid of King Saul his own way. And how God blessed David when he waited for His perfect timing! Maybe we will never have someone chasing us and trying to kill us, like David did. Maybe we will never be tempted to kill anybody, like he was. But we have plenty of other temptations that come our way. Every day brings its own set of temptations to disobey God and His good ways. God helped David and He can help us. He can help us turn away and trust in Jesus as our Savior. This is how we become God's people. And, He can help us to keep on saying 'no' to disobeying Him and to keep on living His good way, instead of giving in to sin.

DDD 12.6 Simple Story Scenes

How Should God's People Live?  
They Should Live Like Jesus...  
By Saying "No" to Disobeying God!

# The Gospel

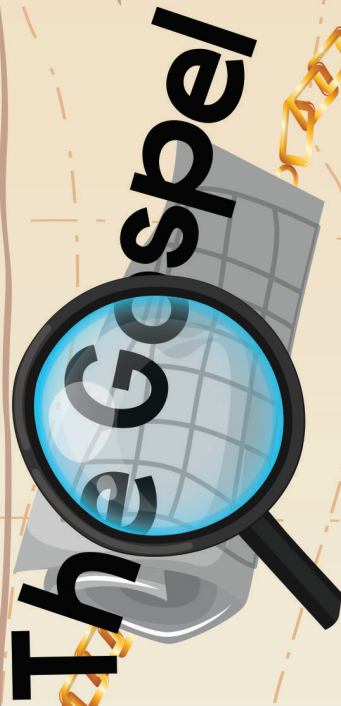

God is the good Creator and King over everything. He gave us His good laws to live by. God has never given us any reason to doubt His goodness, but sadly, we have all given into the temptation to do things our own way. We have chosen to disobey Him and His good ways. And now, we all deserve His punishment.

But God is so merciful! He sent His Son, Jesus, to be our Savior. Jesus lived a perfect life. Then, on the cross, He gave it as the full payment for the sins of God's people. On Day Three, Jesus rose from the dead. He had really beaten sin and death for them.

Now, all who turn away from their sins and trust in Jesus as their Savior can be God's people. This is how we can become

God's people, too. Ask Him to help you do this. He loves to answer this prayer!



## DDD 12.6 Simple Story Scenes



# A Prayer

A God, we praise You for Jesus, Your Perfect Son, who never, ever disobeyed You, no matter how tempting it was.

C God, please forgive us for not saying "no" to disobeying You. Many times, when we are tempted, we choose to forget Your good ways and go ahead and do what we want to do. We need a Savior!

T Thank You, God, for promising to help Your people when they are tempted to do wrong. You promise to always provide them with a way out of sin. Thank You, that we can become Your people through Jesus, too, and You will help us.

S God, please work in our hearts. Help us turn away from our sins and trust in Jesus as our Savior. Help us to say "no" to disobeying You when we are tempted. Help us to choose to live for You, instead, like Jesus did.

In Jesus' name we pray. Amen.



## DDD 12.6 Simple Story Scenes

# **DEEP DOWN DETECTIVES**



**Visual Aids**

**Unit 12,**

**Bible Truth 7**

## About the Deep Down Detectives Visual Aids

### How Are They Used?



The Deep Down Detectives Visual Aids book is a companion resource to be used alongside the Deep Down Detectives Core Curriculum book for each unit. These colorful pictures are used in presenting the key concepts; telling the Bible stories; and, in playing the Bible Story Review games.

### What Do They Include?



**There are four different resources included in this book:**

- 1. Key Concept Visual Aids**-- colorful signs of the Big Question and Answer, the Bible Truth, the Bible verse, and the Listening Assignments to use with the 3 lessons for each Bible Truth.
- 2. The Story Scenes.** Notice that each scene is numbered and that there is a brief summary of the story that corresponds to the picture. You can actually just tell the story in a simple way by using only the text at the bottom of each Story Scene.
- 3. Directions** for making the Deep Down Detectives "Bible" Folder and the **back/front images** to paste in place when making it. (Larger back/front images are found online with the curriculum.)
- 4. Directions** for how to make a homemade flannelgraph storyboard and sturdy Story Scene pictures are found in the back of this book.

### Ready, Set, Rip It Out!

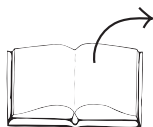

This book is meant to be ripped up and made into your visual aids. The key concept signs can be cut out and laminated or slipped into sheet protectors. The Story Scenes can be put in sheet protectors or laminated, too.

### Store It!



Deep Down Detectives is a curriculum that can be used over and over. Store your visual aids and storyboard pictures after using them and they will serve you for many years. We store ours in manilla envelopes and then put them (along with all the rest of the curriculum) in magazine files, labelled by Bible Truth. If you have multiple classes using the curriculum, store each set of resources in separate manilla envelopes. This will make prep much simpler, second time around.

### Replacement Story Scene Pictures



You can always purchase this book again or simply go online and print out any scenes that go missing.

### Other Options



You can also choose to tell the story in a more traditional flannelgraph way by using your own flannelgraph figures or by purchasing/free downloading the Storyboard Pictures (large and small format size available). This is more complex and requires more preparation, but some love it. And, it does allow for kids to interact more by helping to place pictures up on the board as you tell the story.

**Unit 12: God's People Live for Him**

**Unit Big Question (and Answer):** How Should God's People Live? They Should Live Like Jesus!

**Unit Bible Verse:** "Be imitators of God, as beloved children. And walk in love, as Christ loved us and gave himself up for us." --Ephesians 5:1-2, ESV

**Bible Truth 7 Concept: They Should Live Like Jesus...By Telling the Good News of Jesus!**

After Jesus died on the cross and rose from the dead, He told His disciples to go tell the good news of salvation to the whole world. Jesus wanted people everywhere know how they could become God's people. He wanted them to know that they could know God in their hearts, now. And after they died, they could go and live with God forever. These wonderful gifts would be theirs when they turned away from their sins and trusted in Jesus as their Savior. What good news this was!

Jesus' disciples obeyed Him. They traveled farther and farther away from their homes, sharing the good news of Jesus to all who would listen. Many people rejoiced in this good news. They turned away from their sins and trusted in Jesus as their Savior. God's people were growing in number!

Even today, God still wants His people to keep on sharing this good news to all who will listen. He wants them to share this good news with people who live next door, and with people who live in faraway places. God wants His people to keep on telling about Jesus until the whole world has heard the good news.

How do God's people carry out this big, wonderful job? With the help of God's Holy Spirit! God promises that His Holy Spirit will be at work inside His people. He will help them know what to say and give them the courage to say it. Best of all, God promises to send His Holy Spirit to work in the hearts of those who listen, helping them trust in Jesus and be saved. We can be God's people, too, when we turn away from our sins and trust in Jesus as our Savior.

**Bible Truth 7 Bible Verse: Romans 10:13-15, ESV**

"Everyone who calls on the name of the Lord will be saved." How then will they call on him in whom they have not believed? And how are they to believe in him of whom they have never heard? And how are they to hear without someone preaching? And how are they to preach unless they are sent? As it is written, "How beautiful are the feet of those who preach the good news!"

**Learn a Little:** "How beautiful are the feet of those who preach the good news!"

**Meaning**

These verses remind us that God sends His people to tell others the good news of salvation through Jesus. They must go, if others are to hear and believe. That is how God has planned to save sinners. What a privilege this is to go and tell others! That is what makes their feet beautiful. Not that they have pretty feet (or cute toes), but that by using their feet to go tell others about Jesus, those others can know God and be saved from their sins.

**Bible Truth 7 ACTS Prayer**

- A** God, we praise You for being the God who saves. You made the way for sinful people like us to become Your people. How loving and merciful You are!
- C** God, please forgive us for not telling others about You as You want us to. Forgive us for being scared that others might not want to hear about Jesus or make fun of us. Forgive for not trusting You to be at work as we share the good news about salvation through Him. We need a Savior!
- T** Thank You, God, for offering to make us Your people through Jesus. Thank You for giving us the wonderful, good news of salvation through Him.
- S** God, please work in our hearts. Help us turn away from our sins and trust in Jesus as our Savior. Help us to tell others how they can receive the free gift of salvation through Him, too. Work inside others as they hear about Jesus and help them believe in Him, too. In Jesus' name we pray, Amen.

**Bible Truth 7 Story**

**The Case of the Beautiful, Busy Feet** Acts

**Songs Used in Bible Truth 7**

Big Q & A 12 Song

Big Question 12 Song: How Should God's People Live?

Big Question 12 Bible Verse Song: Walk in Love Ephesians 5:1-2, ESV

*Extra Big Question 12 Bible Verse Song: Let Everyone Who Names the Name 2 Timothy 2:19,22, ESV*

Big Question 12 Hymn: Trust and Obey, v.1

Big Question 12 Praise Song: I Have Decided to Follow Jesus

Bible Truth 7 Bible Verse Song: How Beautiful Romans 10:13-15, ESV

*Extra Bible Truth 7 Bible Verse Song: Be My Witnesses Acts 1:8, ESV*

*listen to or download songs for free at <https://praisefactory.org>: Deep Down Detectives Music page*

**The Case of the Beautiful, Busy Feet**

Acts

**Story-telling Tips**

Ahead of time:

1. Read the Bible verses and story. Pray!
2. Choose story action cues and prepare storyboard figures/story scenes, if using. (In Visual Aids book)
3. Practice telling story with the storyboard pictures, timing your presentation. Shorten, if necessary.

During your presentation:

1. Maintain as much eye contact as possible as you tell the story.
2. Put up storyboard figures/add story action cues/hold up storybook scenes as you tell the story. Allow the children to help you put them on the board, if desired.
3. Include the children in your story with a few questions about what they think will happen or words/concepts that might be new to them.
4. Watch the kids for signs that their attention span has been reached. Shorten, if necessary.

**INTRODUCTION/ LISTENING ASSIGNMENTS**

**"Our story is called: The Case of the Beautiful, Busy Feet. Here is your listening assignment."** Read from Detective Dan's Listening Assignment signs, but questions are summarized below:

**Detective Dan's Lesson #1 Listening Assignment:**

I need to know:

1. Who had beautiful, busy feet?
2. What made the feet beautiful? What were they busy doing?

**Detective Dan's Lesson #2 Listening Assignment:****Our Bible Verse is Romans 10:13-15, ESV**

"Everyone who calls on the name of the Lord will be saved." How then will they call on him in whom they have not believed? And how are they to believe in him of whom they have never heard? And how are they to hear without someone preaching? And how are they to preach unless they are sent? As it is written, "How beautiful are the feet of those who preach the good news!"

I need to know:

1. What message about Jesus did Jesus' followers tell everyone?
2. Why were their feet so busy traveling to faraway places to tell everyone this message?

**Detective Dan's Lesson #3 Listening Assignment:**I found six clues, but two of them are **NOT** in the story.

They are: a sunflower, Jesus' followers, a bird, God's Holy Spirit in a heart, a boat, and a cross. Hold each of them up for the children to see as you identify them.

I need to know:

1. Which four belong in the story and which two don't?
2. What did Jesus's followers ask the Holy Spirit to do in the hearts of those who listened to their good news? How did God answer those prayers?

**Read the assignment questions, THEN SAY,**

"Ok, Deep Down Detectives! Put on your best listening ears and see if you can hear the answers to Detective Dan's questions. When I finish telling the story, we will see if we can answer all the questions."

*Read the Bible Truth story, answer questions, present the gospel and lead in prayer.*

*Answers to questions; the gospel; and, ACTS prayer are included with the story text.*

**The Case of the Beautiful, Busy Feet** *Acts**Story with lines separating paragraphs (text in bold, optional interaction cues in italics)*

---

**Jesus and His disciples stood together on the Mount of Olives, a hill near the city of Jerusalem. This would be the last time they would be together on earth.**

**Jesus had died on the cross and was buried in a grave. Then, on Day Three, He rose from the dead and appeared to His disciples. For the next forty days, Jesus taught them about God's good plans from the Bible. How wonderful it had been to have Jesus with them again!**

---

**But now, those days were over. It was time for Jesus to go to heaven and rule. Before He went, Jesus told his disciples about the job He had for them. "Be My witnesses," Jesus told them. "Tell everyone what I've done. Tell them how they can become God's people. Teach them everything I've taught you. Make them My disciples," Jesus said. "Start right here in Jerusalem, but don't stop there! This good news is for the whole world," Jesus told them.**

**"Go through all of Judea, this land you live in. Tell everyone the good news. But don't stop there! Go to Samaria, to your enemies who live in the land next to you. Tell them the good news, but don't stop there, either!" Jesus said, "Keep on going and telling, to the very ends of the earth. Every people, in every part of the world, need to hear this wonderful, good news of salvation through faith in Me!"**

**Wow! Jesus was giving His disciples a big job! Could they really do all of this? Tell the WHOLE WORLD?**

---

*What do you think?*

**Wow! Jesus was giving His disciples a big job! Could they really do all of this? Tell the WHOLE WORLD? Well... no, they couldn't. Not on their own. But yes, they could, because God was going to give them a powerful Helper. "I will ask the Father and He will send the Holy Spirit to live in your hearts," Jesus told them. "HE will give you the wisdom and power you need to tell the whole world," Jesus told them. "And, when this wonderful, good news of salvation has reached all peoples, in all places, I will come back," Jesus promised. When Jesus finished saying all these things, He went up through the clouds to heaven.**

---

**The disciples were sad for Jesus to leave them, but they were happy about His promises. How exciting! The Holy Spirit would live inside their hearts! They would get to tell everyone the good news about Jesus. And one day, when their job was finished, Jesus would come back! Yes, this was all very, very exciting!**

**But what should they do first? Where should they go? Jesus told them. What did He say?**

*Can you remember?*

**"Start in Jerusalem. Wait there for the gift of the Holy Spirit!" Jesus told them; so, that's just where they went and just what they did!**

---

**In Jerusalem, they waited and prayed until God's Holy Spirit came to live inside them, just as Jesus promised. The disciples burst out into the streets of Jerusalem, and helped by the Holy Spirit, they spread the good news of Jesus: "Turn away from disobeying God! Trust in Jesus as your Savior!" they told all who would listen. "God will forgive your sins and make you, His people. You can know and love God in your hearts, right now. And when you die, you can live with Him and enjoy Him forever," they promised. "Believe this wonderful, good news today!" they urged everyone.**



*Story with lines separating paragraphs (text in bold, optional interaction cues in italics)*

---

**The Holy Spirit began to work in the hearts of many that day. And guess what happened next?**

*Can you guess?*

**They turned away from their sins and trusted in Jesus as their Savior. Yay!**

---

**Thousands of new believers joined Jesus' first disciples. They gathered together as a church to pray and learn from God's Word. They encouraged each other to love God and love one another like sisters and brothers. And, they encouraged each other to do the job Jesus gave them. Can you remember what that job was?**

*Can you remember?*

**"Be My witnesses! Tell the whole world about Me!" Jesus had told them. Now, it was time to do it!**

---

**Some stayed in Jerusalem. They kept on telling others the good news of Jesus there. But many others left Jerusalem. Jesus told them to go to the whole world, so that's what they did.**

**Some went to the little towns of their homeland, Judea. And what did they remember as they moved? Jesus' last words: "Be My witnesses! Tell the whole world the wonderful, good news of salvation through faith in Me."**

---

**And so, they did. "Turn away from disobeying God and trust in Jesus as your Savior," they told people in Judea. "God will forgive your sins and make you, His people. You can know and love God in your hearts, right now. And when you die, you will live with Him and enjoy Him forever. Believe this wonderful, good news today!" they urged the people in Judea.**

**Many heard this wonderful, good news and believed! Now, they were God's people, brothers and sisters through Jesus!**

**Some of Jesus' followers left Judea and went even farther away. Some, like Philip, went to Samaria, the nearby land of their enemies. And what did Philip and the others remember as they went? Jesus' last words. Can you remember them?**

*Can you?*

**"Be My witnesses! Tell the whole world the wonderful, good news of salvation through faith in Me!" Jesus had told them.**

---

**So, that's what Philip and others did: "Turn away from disobeying God and trust in Jesus as your Savior," they told their enemies in Samaria. "God will forgive your sins and make you, His people. You can know and love God in your hearts, right now. And when you die, you will live with Him and enjoy Him forever. Believe this wonderful, good news today!" they urged.**

**Many of these enemies heard and believed! They weren't enemies, anymore! Now, they were God's people, brothers and sisters through Jesus!**

*Story with lines separating paragraphs (text in bold, optional interaction cues in italics)*

**Others, like Paul and Barnabas, went even farther away. They sailed on ships over the wavy seas to islands. They walked miles and miles to other faraway places. Over tall mountains, down deep valleys, along the seashore, they travelled. Wherever people were, they went. And what did they remember as they went to all these places? Jesus' last words. Can you remember them?**

*Can you?*

**"Be My witnesses! Tell the whole world the wonderful, good news of salvation through faith in Me!" Jesus had told them.**

**So, that's what Paul and Barnabas did: "Turn away from disobeying God and trust in Jesus as your Savior," they told the peoples in those faraway places. "God will forgive your sins and make you, His people. You can know and love God in your hearts, right now. And when you die, you will live with Him and enjoy Him forever. Believe this wonderful, good news today!" they urged.**

**Many in these faraway places heard this wonderful, good news and believed! Now, they were God's people, brothers and sisters through Jesus!**

**Many years have passed since Jesus told His disciples to tell the world how He can be their Savior. And all this time, as His disciples have kept on spreading the good news, the Holy Spirit has been at work in the hearts of people. Now, millions, even billions, of people have become God's people, brothers and sisters through Jesus. But did you know the job is STILL not finished?**

**But did you know the job is STILL not finished? There are still so many people who need to hear the good news of Jesus. Million, even billions, of people. Who will tell THEM about Him? Can you guess?**

*Can you guess?*

**God's people, living today, that's who! Jesus wants His disciples to keep on telling everyone, all over this world, how He can become their Savior. People who live near them need to hear. People who live far away from them need to hear. And everyone who lives in between needs to hear, too! They ALL need to hear the wonderful, good news of Jesus, that they might turn away from disobeying God, trust Jesus as their Savior, and be saved!**

**And who will help God's people finish this big job? The same Person who helped those believers, long ago. Can you remember who?**

*Can you remember His name?*

**God's Holy Spirit, that's who! He is living in their hearts, helping God's people do the job Jesus gave them. He's at work in those who hear the good news of Jesus, too, helping them turn away from their sins and trust in Jesus as their Savior.**

**On and on, God's people will remember Jesus' last words to them. What are they again?**

*Can you remember them?*

**"Be My witnesses! Tell the whole world the wonderful, good news of salvation through faith in Me!" Jesus had told them.**

**Yes, they will keep on doing the job God gave them, until all of God's people are saved, millions and billions, even trillions of people. More people than we can count. Wow! And THEN, at last, it will be time for Jesus to come back. He will take His people to live with Him in the new heaven and earth forever. What a great day that will be! It will be Perfect Wonderfulness!**

**Cracking the Case:** (story wrap-up for Listening Assignments)

It's time to see how we did with our Listening Assignment.

**Detective Dan's Lesson 1 Listening Assignment:**

**1. Who had beautiful, busy feet?** God's people.  
**2. What made the feet beautiful? What were they busy doing?** They were using their feet to travel to faraway places to tell others about Jesus. People turned away from their sins and trusted in Jesus as their Savior. They became God's people, too. They were so grateful that someone would walk so far just so they could hear about Jesus. That's why they called the feet of these messengers beautiful!

**For You and Me:**

Jesus' first followers were busy going into the world, telling everyone about Jesus. They wanted everyone to turn away from their sins and trust in Jesus as their Savior. They wanted them all to be God's people forever. Jesus still sends out His followers so that many more people might trust in Him as their Savior. Why, your teachers, even today, are telling you this good news, so that YOU might turn away from your sins and trust in Jesus as your Savior. They want you to be God's people too. I guess that means they have beautiful feet!

**Detective Dan's Lesson 2 Listening Assignment:**  
**Our Bible Verse is Romans 10:13-15, ESV**

"Everyone who calls on the name of the Lord will be saved." How then will they call on him in whom they have not believed? And how are they to believe in him of whom they have never heard? And how are they to hear without someone preaching? And how are they to preach unless they are sent? As it is written, "How beautiful are the feet of those who preach the good news!"

**I need to find out:**

**1. What message about Jesus did Jesus' followers tell everyone?** That they could become God's people when they turned away from their sins and trusted in Jesus as their Savior.  
**2. Why were their feet so busy traveling to faraway places to tell everyone this message?** Only by going to these faraway places would the people who lived there hear about Jesus, turn away from their sins, and be saved. This was the only way they could get to become God's people.

**For You and Me:**

Jesus' first followers were busy going into the world, telling everyone about Jesus. They wanted everyone to turn away from their sins and trust in Jesus as their Savior. They wanted them to be God's people forever. Jesus still sends out his followers today. He still wants people to trust in Him as their Savior. Why, your teachers, even today, are telling you this good news so that YOU might turn away from your sins and trust in Jesus as your Savior. They want you to be God's people too. I guess that means they have beautiful feet, too!

**Detective Dan's Lesson 3 Listening Assignment:**

Our six clues were: a sunflower, Jesus' followers, a bird, God's Holy Spirit in a heart, a boat, and a cross.

**1. Which four belong in our story?**

Jesus' followers, God's Holy Spirit in a heart, the boat and the cross belong. The sunflower and the bird do not.

**2. What did Jesus's followers ask the Holy Spirit to do in the hearts of those who listened to their good news? How did God answer those prayers?** They asked the Holy Spirit to help people turn away from their sins and trust in Jesus as their Savior. The Holy Spirit DID work in the hearts of many and they were saved!

**For You and Me:**

The Holy Spirit worked in the hearts of many who heard the good news of Jesus, long ago. He can work in our hearts, too. He can help us turn away from our sins and trust in Jesus as our Savior. Ask Him to help you today! He loves to answer this prayer!

**The Gospel** (story wrap-up if NOT using Listening Assignments)**Our Bible Truth is:**

**Can You Tell Me What the LORD Is Like?  
They Should Live Like Jesus...  
By Telling the Good News of Jesus!**

How should God's people live each day? They should live like Jesus... by telling others the good news of Jesus. God's people know how important it is to tell others the good news of Jesus. After all, someone told them! That's how they knew that they should turn away from disobeying God and trust in Jesus as their Savior. They want to tell others this same good news so that they might be saved, too. Why, that's the reason I'm telling the good news of Jesus to you right now! So YOU, too, might turn away from disobeying God and trust in Jesus as your own Savior. I want you to know special closeness with God, too! There is nothing better in life than knowing Him! *Close in prayer.*

**Closing ACTS Prayer**

- A** God, we praise You for being the God who saves. You made the way for sinful people like us to become Your people. How loving and merciful You are!
- C** God, please forgive us for not telling others about You as You want us to. Forgive us for being scared that others might not want to hear about Jesus or make fun of us. Forgive for not trusting You to be at work as we share the good news about salvation through Him. We need a Savior!
- T** Thank You, God, for offering to make us Your people through Jesus. Thank You for giving us the wonderful, good news of salvation through Him.
- S** God, please work in our hearts. Help us turn away from our sins and trust in Jesus as our Savior. Help us to tell others how they can receive the free gift of salvation through Him, too. Work inside others as they hear about Jesus and help them believe in Him, too.

In Jesus' name we pray, Amen.

***Go to Lesson Plan, p.9 for the script to the rest of the lesson.***

# How should God's people live?

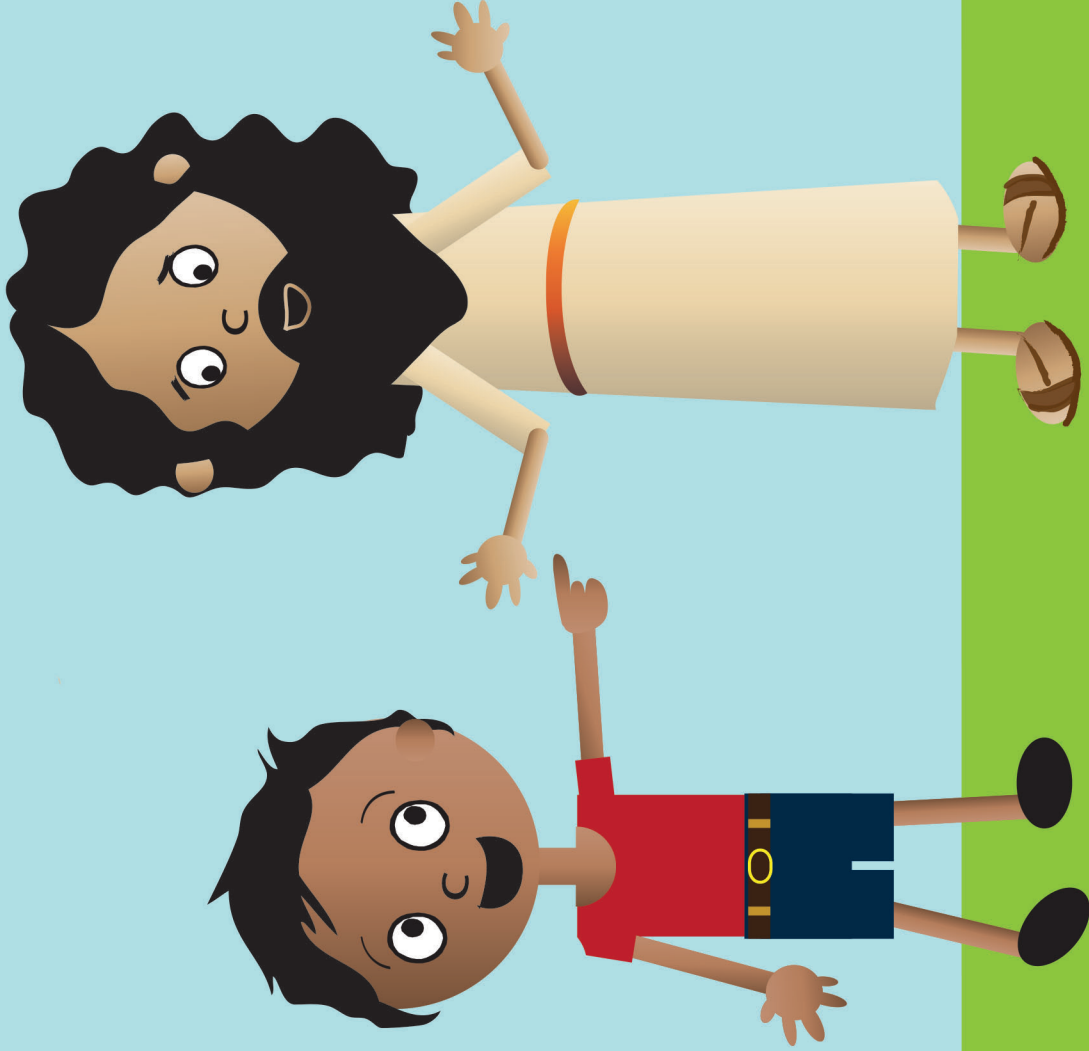

ANSWER:

# They should live like Jesus!

VISUAL  
AID

#1

take out  
BIG  
QUESTION  
of BQB

## The Big Question

*Hold up the Big Question sign for all the children to see, and say:*

The Big Question we are investigating today is Big Question

Number 12:

**How Should God's People Live?**

and the Answer is:

**They Should Live Like Jesus!**

### Meaning:

We become God's people when we turn away from our sins and trust in Jesus as our Savior. When we do, God forgives our sins, and we begin a whole new way of life. God's people no longer live life just to please themselves. They want to honor God with their whole lives, like Jesus did. They seek to love God most of all and love all people, too.

Let's sing our Big Question Song: "

## Big Q & A 12 Song

*DDD ESV Songs 12, track 12*

*(adapted version of "Pop, Goes the Weasel")*

How should God's people live each day?

They should live like Jesus!

How should God's people live each day?

How should God's people live each day?

How should God's people live each day?

They should live like Jesus!

# BIG QUESTION 12: Eight truths about how God's people live

1. A boy kneeling in prayer with a speech bubble saying "Please God, HELP!".

2. A boy holding a pink heart with the word "God" written on it.

3. A group of four children holding hands in a circle.

4. A boy and a girl celebrating with confetti and streamers. A large sunburst behind them contains the words "THE LORD".

5. A boy and a girl holding a large sign that says "The Bible".

6. A boy with a thought bubble containing a crossed-out mess of brown paint.

7. A boy and a girl standing on a globe with a large wooden cross in the center.

8. A boy holding a colorful striped banner that says "God is So Wonderful!".

Visual take out  
Aid

#2

The  
Question  
Briefcase  
of BQB

## **This Unit's Bible Truths**

"They Should Live Like Jesus" is a good beginning, but there's so more to learn. So it's time for us to dig down even deeper for more answers to our Big Question about God. We're going to be learning EIGHT Bible truths that all tell us more about how God wants His people to live.

Who would like to hand me the picture with our eight Bible truths on it? It's in the Big Question Box/Briefcase."

*Choose a child to get it and hand it to you, then hold it up and show them the pictures of the eight truths they will be learning.*

*After everyone has had a good look say...*

"Ok, we've learned six truths about how to live for God. They are: "By Asking God for His Help," "By Loving God Most of All," "By Loving Other People As God Has Loved Them," "By Trusting God and Being Happy with What He Wants," "By Learning God's Word and Obeying It," and, "By Saying "No" to Disobeying God." (point to pictures as you identify each Bible Truth). Now let's look at our Bible Truth Clue sign and see if we can figure out which of these eight truths we will be learning about today. Who would like to get it out of the Big Question Briefcase for me?"

*Choose a child to open the briefcase, take out the Bible Truth Clue sign and hand it to you.*



CAN YOU GUESS BIBLE TRUTH 7?

How Should God's People Live?  
They Should Live Like Jesus...

By Telling the  
Good News of ????!

HINT: What is the name of God's Son,  
sent to save us? It starts with a "J"  
and it rhymes with "breezes."

ANSWER:  
By Telling the Good News  
of JESUS!

DDD 12.7 Bible Truth

Visual take out

Aid

#3



of BQB



# Revealing the Bible Truth We Are Learning

*Hold up the front side for the children to see. Cover up the answer, written along the bottom, and say:*

**“How Should God’s People Live?  
They Should Live Like Jesus!  
By Telling the Good News of ?????!”**

We’re missing one word. Here’s the hint to what the missing word is. It says: “What is the name of God’s Son, sent to save us? It starts with a “J” and it rhymes with “breezes.”

Can you guess? It’s “JESUS.”

So, the Bible Truth we are learning today is:

*(Uncover answer from bottom of sign, show it to them and say:)*

**“How Should God’s People Live?  
They Should Live Like Jesus!  
By Telling the Good News of JESUS!!”**

And here is what this Bible Truth means:

*(read the meaning off of the back of the sign, say:)*

After Jesus died on the cross and rose from the dead, He told His disciples to go tell the good news of salvation to the whole world. Jesus wanted people everywhere know how they could become God’s people. He wanted them to know that they could know God in their hearts, now. And after they died, they could go and live with God forever. These wonderful gifts would be theirs when they turned away from their sins and trusted in Jesus as their Savior. What good news this was!

Jesus’ disciples obeyed Him. They traveled farther and farther away from their homes, sharing the good news of Jesus to all who would listen. Many people rejoiced in this good news. They turned away from their sins and trusted in Jesus as their Savior. God’s people were growing in number!

Even today, God still wants His people to keep on sharing this good news to all who will listen. He wants them to share this good news with people who live next door, and with people who live in faraway places. God wants His people to keep on telling about Jesus until the whole world has heard the good news.

How do God’s people carry out this big, wonderful job? With the help of God’s Holy Spirit! God promises that His Holy Spirit will be at work inside His people. He will help them know what to say and give them the courage to say it. Best of all, God promises to send His Holy Spirit to work in the hearts of those who listen, helping them trust in Jesus and be saved. We can be God’s people, too, when we turn away from our sins and trust in Jesus as our Savior.



**“Everyone who calls on the name of the Lord will be saved.” How then will they call on him in whom they have not believed? And how are they to believe in him of whom they have never heard? And how are they to hear without someone preaching? And how are they to preach unless they are sent? As it is written, “How beautiful are the feet of those who preach the good news!” -- Romans 10:13-15, ESV**

## Bible Truth 7 Bible Verse

*Remove the Bible Verse Picture from the "Bible" folder and hold it up for all the children to see, then say:*

Romans 10:13-15 tells us:

### **Romans 10:13-15:**

"Everyone who calls on the name of the Lord will be saved." How then will they call on him in whom they have not believed? And how are they to believe in him of whom they have never heard? And how are they to hear without someone preaching? And how are they to preach unless they are sent? As it is written, "How beautiful are the feet of those who preach the good news!"

### **Learn a Little:**

How beautiful are the feet of those who preach the good news!"

### **What does that mean?**

These verses remind us that God sends His people to tell others the good news of salvation through Jesus. They must go, if others are to hear and believe. That is how God has planned to save sinners. What a privilege this is to go and tell others! That is what makes their feet beautiful. Not that they have pretty feet (or cute toes), but that by using their feet to go tell others about Jesus, those others can know God and be saved from their sins.

"Now it's time to do a bit more deep down investigating. Let's see what Detective Dan wants us to help him figure out. Would someone like to get it out for me?"

"We've said our Bible verse, now let's sing it!"

"We've said our Bible verse, now let's sing it!"

## How Beautiful:

### Romans 10:13-15

*DDD ESV Songs 12, track 41*

#### Refrain

How beautiful! How beautiful!

How beautiful are the feet.

How beautiful! How beautiful!

Are the feet of those who preach the good news.

Ev'ryone who calls on the name of the Lord,

Will be saved.

Ev'ryone who calls on the name of the Lord,

Will be saved.

Yes, but I have some questions....

How then will they call on Him they've not believed in?

How are they to believe in Him they never heard?

How are they to hear without someone preaching?

How are they to preach unless they are sent?

Well, it all goes back to those feet! Refrain

Romans Ten, thirteen through fifteen.

"Now it's time to do a bit more deep down investigating. Let's see what Detective Dan wants us to help him figure out. Would someone like to get it out for me?"

take out



Place in



Visual Aid

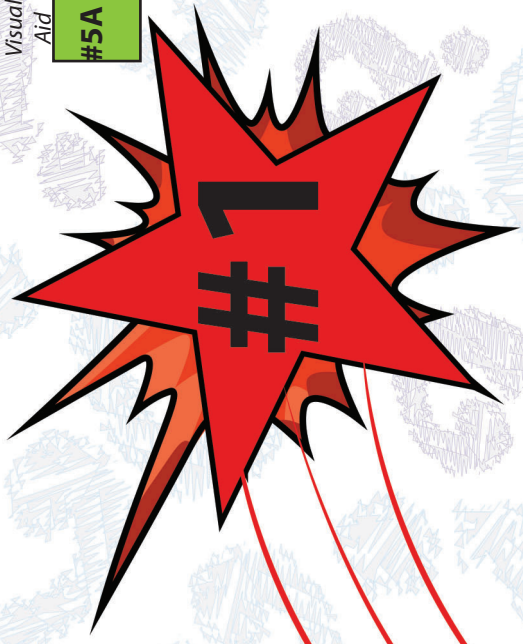

# Detective Dan's Listening Assignment #1

# Detective Dan's

## Listening Assignment #1



Hi, Deep Down Detectives!

I'm working on a brand-new case called:

“The Case of the Beautiful, Busy Feet.”

I need to find out:

1. Who had beautiful, busy feet?

AND

2. What made the feet beautiful? What were they busy doing?

Can you help me? Listen carefully to the story and you might just hear the answers!

Thanks!

Detective Dan

***Then say,*** “Ok, Deep Down Detectives! Put on your best listening ears and see if you can hear the answers to Detective Dan's questions. When I finish telling the story, we will see if we can answer all of his questions.”

*Read the Bible Truth story, putting up the storyboard pictures as you tell it.*

*At the end of the story, repeat the questions and lead the children in answering them. Present the gospel and close in prayer.*

\*Answers to assignment questions, the gospel and ACTS prayer are also included at the end of the story text.\*

Answers:

1. **Who had beautiful, busy feet?** God's people.

2. **What made the feet beautiful? What were they busy doing?** They were using their feet to travel to faraway places to tell others about Jesus. People turned away from their sins and trusted in Jesus as their Savior. They became God's people, too. They were so grateful that someone would walk so far just so they could hear about Jesus. That's why they called the feet of these messengers beautiful!

**For You and Me:**

Jesus' first followers were busy going into the world, telling everyone about Jesus. They wanted everyone to turn away from their sins and trust in Jesus as their Savior. They wanted them all to be God's people forever. Jesus still sends out His followers so that many more people might trust in Him as their Savior. Why, your teachers, even today, are telling you this good news, so that YOU might turn away from your sins and trust in Jesus as your Savior. They want you to be God's people too. I guess that means they have beautiful feet!

take out



of BQB

Place in



Visual Aid



# Detective Dan's Listening Assignment #2

# Detective Dan's

## Listening Assignment #2



Hi, Deep Down Detectives!

I'm still working on the case called:

"The Case of the Beautiful, Busy Feet."

Our Bible Verse is Romans 10:13-15, ESV:

"Everyone who calls on the name of the Lord will be saved." How then will they call on him in whom they have not believed? And how are they to believe in him of whom they have never heard? And how are they to hear without someone preaching? And how are they to preach unless they are sent? As it is written, "How beautiful are the feet of those who preach the good news!"

I need to find out:

1. **What message about Jesus did Jesus' followers tell everyone?**

AND

2. **Why were their feet so busy traveling to faraway places to tell everyone this message?**

Can you help me? Listen carefully to the story and you might just hear the answers!

Thanks for your help!

Detective Dan

**Then say,** "Ok, Deep Down Detectives! Put on your best listening ears and see if you can hear the answers to Detective Dan's questions. When I finish telling the story, we will see if we can answer all of his questions."

*Read the Bible Truth story, putting up the storyboard pictures as you tell it. At the end of the story, repeat the questions and lead the children in answering them. Present the gospel and close in prayer.*

\*Answers to assignment questions, the gospel and ACTS prayer are also included at the end of the story text.\*

Answers:

**Our Bible Verse is Romans 10:13-15, ESV:**

"Everyone who calls on the name of the Lord will be saved." How then will they call on him in whom they have not believed? And how are they to believe in him of whom they have never heard? And how are they to hear without someone preaching? And how are they to preach unless they are sent? As it is written, "How beautiful are the feet of those who preach the good news!"

I need to find out:

1. **What message about Jesus did Jesus' followers tell everyone?** That they could become God's people when they turned away from their sins and trusted in Jesus as their Savior.

2. **Why were their feet so busy traveling to faraway places to tell everyone this message?** Only by going to these faraway places would the people who lived there hear about Jesus, turn away from their sins, and be saved. This was the only way they could get to become God's people.

**For You and Me:**

Jesus' first followers were busy going into the world, telling everyone about Jesus. They wanted everyone to turn away from their sins and trust in Jesus as their Savior. They wanted them to be God's people forever. Jesus still sends out his followers today. He still wants people to trust in Him as their Savior. Why, your teachers, even today, are telling you this good news so that YOU might turn away from your sins and trust in Jesus as your Savior. They want you to be God's people too. I guess that means they have beautiful feet, too!



take out



Place in



Visual Aid

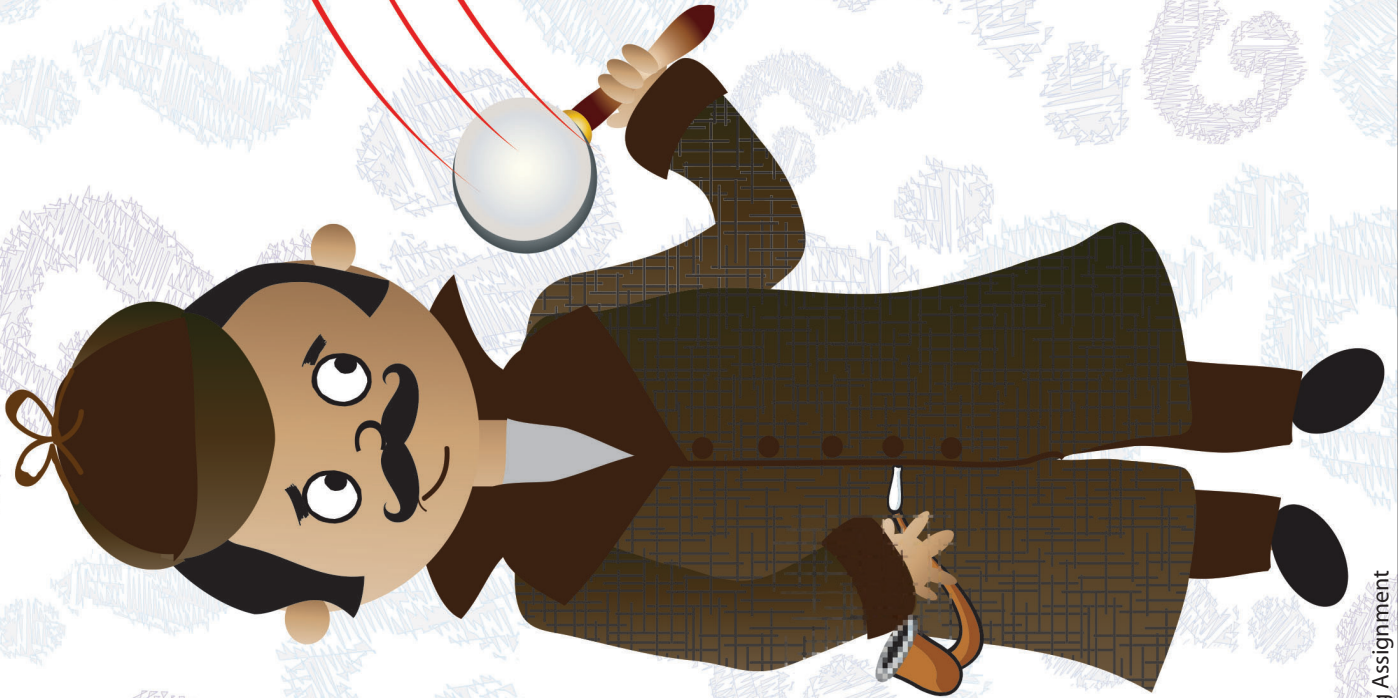

# Detective Dan's Listening Assignment #3

# Detective Dan's

## Listening Assignment #3



Hi, Deep Down Detectives!

I'm still working on the case called:

“The Case of the Beautiful, Busy Feet.”

I found **SIX** clues, but **TWO** of them are **NOT** in the story.

**They are: a sunflower, Jesus' followers, a bird, God's Holy Spirit in a heart, a boat, and a cross.**

*Hold up each of the six pictures for the children to see as you identify them. Better yet, put them up on your flannelgraph board, off to one side.*

I need to know:

1. Which **FOUR** pictures belong in the story and which **TWO** do **NOT**?
2. What did Jesus's followers ask the Holy Spirit to do in the hearts of those who listened to their good news? How did God answer those prayers?

Can you help me? Listen carefully to the story and you might just hear the answers!

Thanks!

Detective Dan

**Then say,** “Ok, Deep Down Detectives! Put on your best listening ears and see if you can hear the answers to Detective Dan's questions. When I finish telling the story, we will see if we can answer all of his questions.”

*Read the Bible Truth story, putting up the storyboard pictures as you tell it. At the end of the story, repeat the questions and lead the children in answering them. Present the gospel and close in prayer.*

\*Answers to assignment questions, the gospel and ACTS prayer are also included at the end of the story text.\*

Answers:

**1. Which four belong in our story?**

Jesus' followers, God's Holy Spirit in a heart, the boat and the cross belong. The sunflower and the bird do not.

**2. What did Jesus's followers ask the Holy Spirit to do in the hearts of those who listened to their good news? How did God answer those prayers?** They asked the Holy Spirit to help people turn away from their sins and trust in Jesus as their Savior. The Holy Spirit **DID** work in the hearts of many and they were saved!

**For You and Me:**

The Holy Spirit worked in the hearts of many who heard the good news of Jesus, long ago. He can work in our hearts, too. He can help us turn away from our sins and trust in Jesus as our Savior. Ask Him to help you today! He loves to answer this prayer!



Jesus' Followers



A Sunflower

VISUAL  
AID  
#5C

Place in  
DDD  
Bible™

take out  
Big  
Question  
Briefcase  
of BQB

DDD 127 Lesson 3 Listening Assignment Clue Picture 2 for kids

VISUAL  
AID  
#5C

Place in  
DDD  
Bible™

take out  
Big  
Question  
Briefcase  
of BQB

DDD 12.7 Lesson 3 Listening Assignment Clue Picture 1 for kids

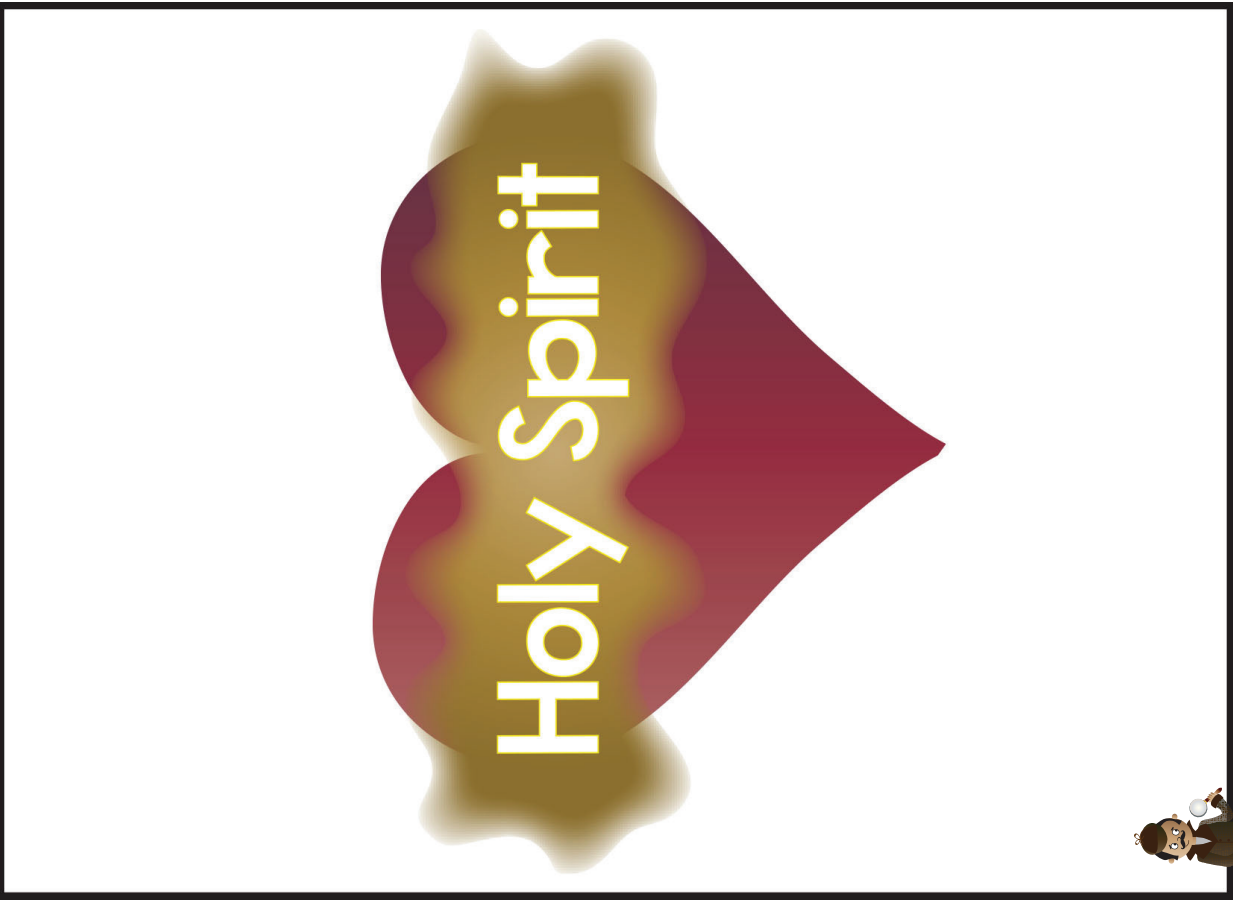

God's Holy Spirit in a Heart

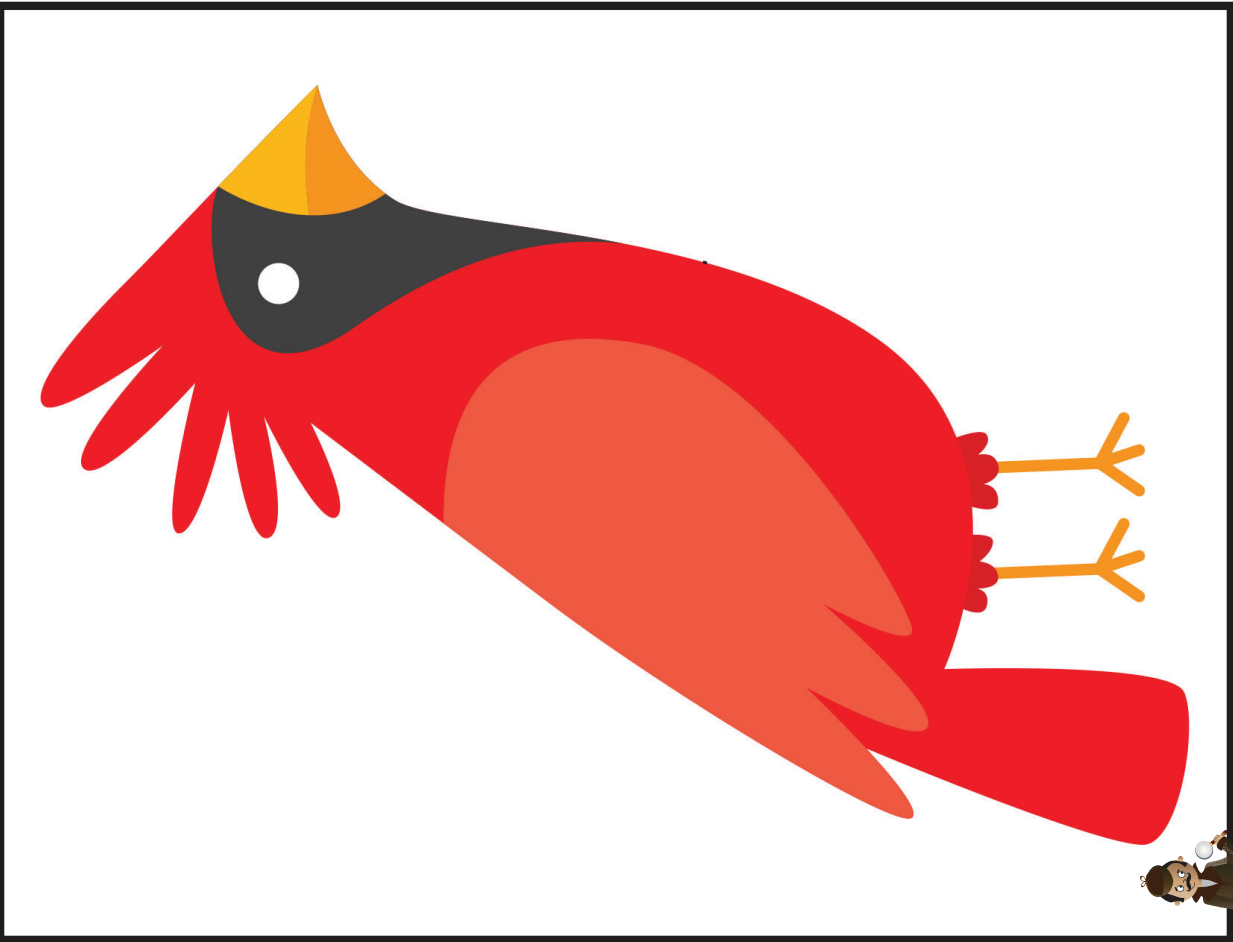

A Bird

VISUAL  
AID  
#5C

Place in  
DDD  
Bible™

take out  
Big  
Question  
Bible™  
of BQB

DDD 12.7 Lesson 3 Listening Assignment Clue Picture 4 for kids

VISUAL  
AID  
#5C

Place in  
DDD  
Bible™

take out  
Big  
Question  
Bible™  
of BQB

DDD 12.7 Lesson 3 Listening Assignment Clue Picture 3 for kids

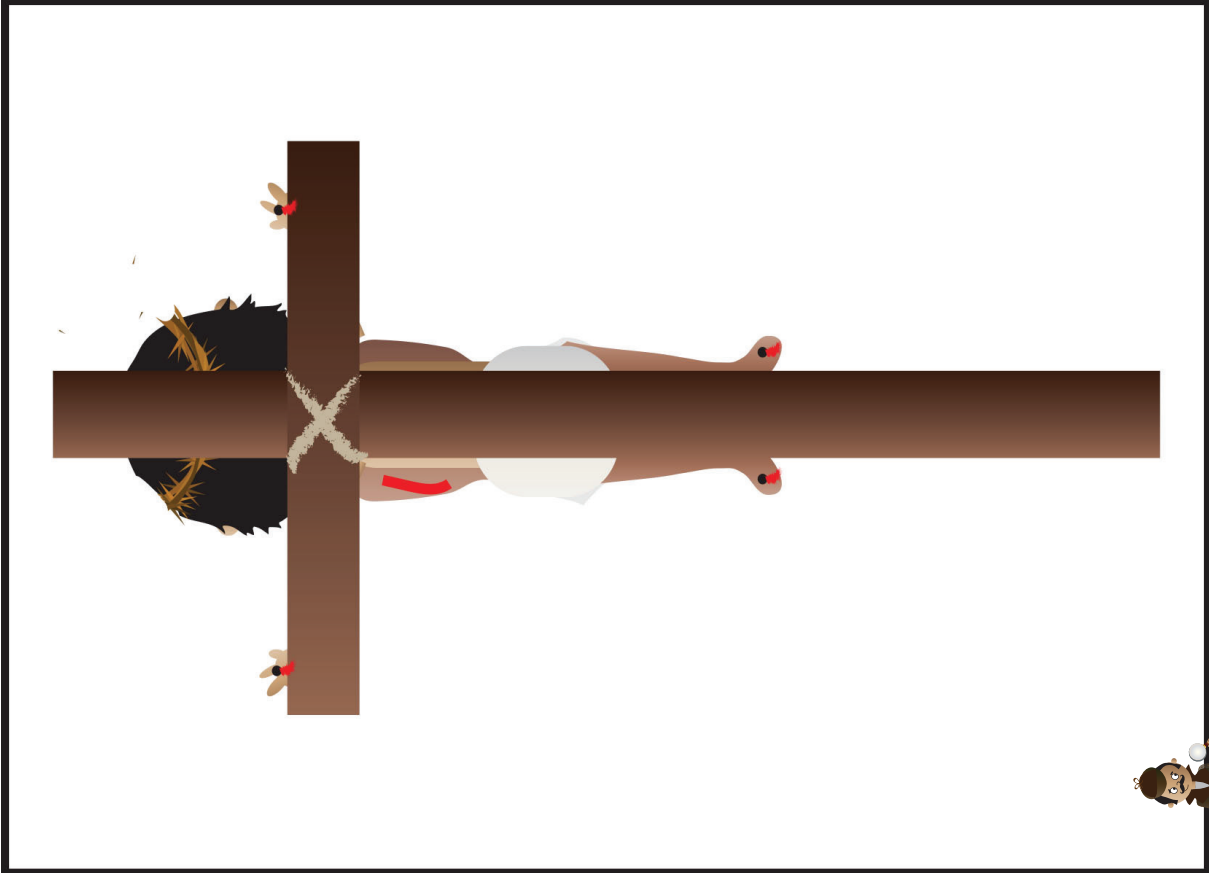

A Cross

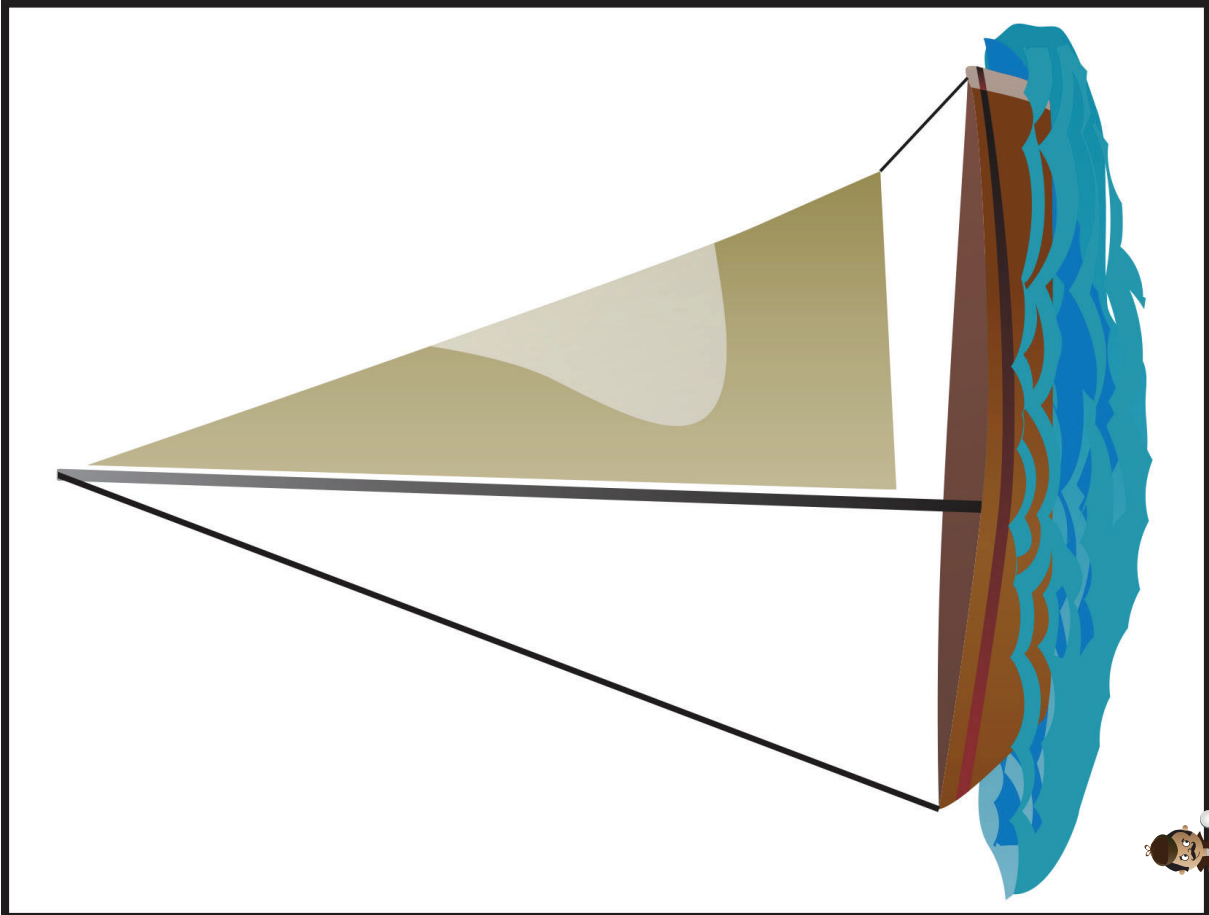

A Boat

VISUAL  
AID  
#5C

Place in  
DDD  
Bible™

take out  
Big  
Question  
Briefcase  
of BQB

DDD 12.7 Lesson 3 Listening Assignment Clue Picture 6 for kids

VISUAL  
AID  
#5C

Place in  
DDD  
Bible™

take out  
Big  
Question  
Briefcase  
of BQB

DDD 12.7 Lesson 3 Listening Assignment Clue Picture 5 for



# “The Case of the Beautiful, Busy Feet” Acts

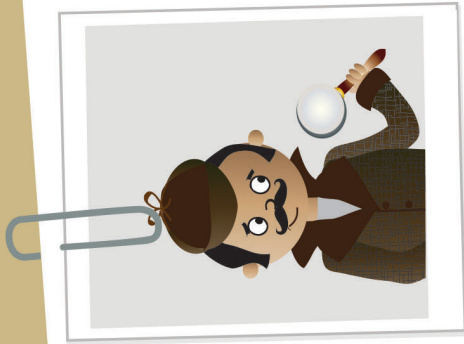

## Detective Dan's Listening Assignment #1

1. Who had beautiful, busy feet?
2. What made the feet beautiful? What were they busy doing?



## Detective Dan's Listening Assignment #2

### Romans 10:13, 15, ESV

“Everyone who calls on the name of the Lord will be saved.” ... As it is written, “How beautiful are the feet of those who preach the good news!”

1. What message about Jesus did Jesus' followers tell everyone?
2. Why were their feet so busy traveling to faraway places to tell everyone this message?

(more listening and discussion questions are included in the curriculum at [praisefactory.org](http://praisefactory.org))

**I. Jesus and His disciples stood together on the Mount of Olives, a hill near the city of Jerusalem. This would be the last time they would be together on earth.**

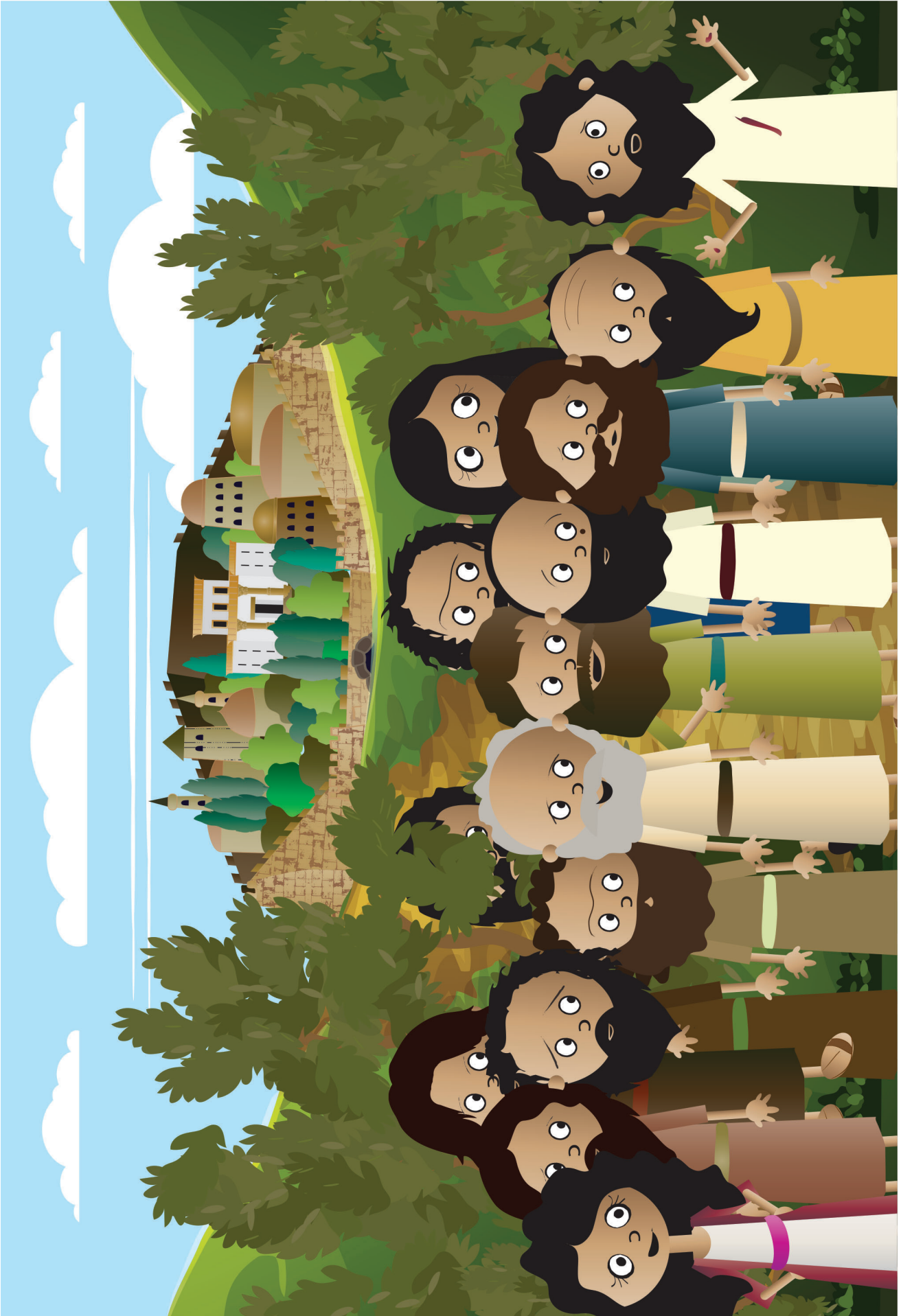

**I. Jesus and His disciples stood together on the Mount of Olives, a hill near the city of Jerusalem. This would be the last time they would be together on earth.**

**2. Jesus had died on the cross and was buried in a grave. Then, on Day Three, He rose from the dead and appeared to His disciples.**

**For the next forty days, Jesus taught them about God's good plans from the Bible. How wonderful it had been to have Jesus with them again!**



2. Jesus had died on the cross and was buried in a grave. Then, on Day Three, He rose from the dead and appeared to His disciples. For the next forty days, Jesus taught them about God's good plans from the Bible. How wonderful it had been to have Jesus with them again!

**3. But now, those days were over. It was time for Jesus to go to heaven and rule.**

**Before He went, Jesus told his disciples about the job He had for them. “Be My witnesses,” Jesus told them. “Tell everyone what I’ve done. Tell them how they can become God’s people. Teach them everything I’ve taught you. Make them My disciples,” Jesus said.**

**“Start right here in Jerusalem, but don’t stop there! This good news is for the whole world,” Jesus told them.**



3. But now, those days were over. It was time for Jesus to go to heaven and rule. Before He went, Jesus told his disciples about the job He had for them. "Be My witnesses," Jesus told them. "Tell everyone what I've done. Tell them how they can become God's people. Teach them everything I've taught you. Make them My disciples," Jesus said. "Start right here in Jerusalem, but don't stop there! This good news is for the whole world," Jesus told them.

**4. “Go through all of Judea, this land you live in. Tell everyone the good news. But don’t stop there! Go to Samaria, to your enemies who live in the land next to you. Tell them the good news.”**

**“But don’t stop there, either!” Jesus said, “Keep on going and telling, to the very ends of the earth. Every people, in every part of the world, need to hear this wonderful, good news of salvation through faith in Me!”**





4. "Go through all of Judea, this land you live in. Tell everyone the good news. But don't stop there! Go to Samaria, to your enemies who live in the land next to you. Tell them the good news. But don't stop there, either!" Jesus said, "Keep on going and telling, to the very ends of the earth. Every people, in every part of the world, need to hear this wonderful, good news of salvation through faith in Me!"

**5. Wow! Jesus was giving His disciples a big job! Could they really do all of this? Tell the WHOLE WORLD?**

**Well... no, they couldn't. Not on their own. But yes, they could, because God was going to give them a powerful Helper.**

**"I will ask the Father and He will send the Holy Spirit to live in your hearts," Jesus told them. "He will give you the wisdom and power you need to tell the whole world," Jesus told them. "And, when this wonderful, good news of salvation has reached all peoples, in all places, I will come back," Jesus promised.**

# Holy Spirit

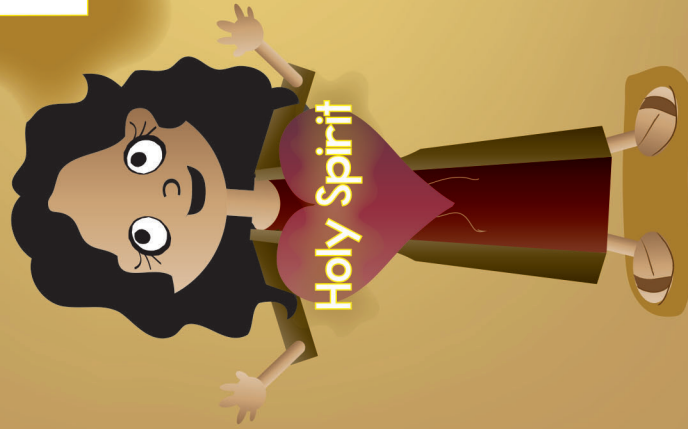

5. Wow! Jesus was giving His disciples a big job! Could they really do all of this? Tell the **WHOLE WORLD?** Well... no, they couldn't. Not on their own. But yes, they could, because God was going to give them a powerful Helper. "I will ask the Father and He will send the Holy Spirit to live in your hearts," Jesus told them. "HE will give you the wisdom and power you need to tell the whole world," Jesus told them. "And, when this wonderful, good news of salvation has reached all peoples, in all places, I will come back," Jesus promised.

**6. When Jesus finished saying all these things, He went up through the clouds to heaven. The disciples were sad for Jesus to leave them, but they were happy about His promises.**

**How exciting! The Holy Spirit would live inside their hearts! They would get to tell everyone the good news about Jesus. And one day, when their job was finished, Jesus would come back! Yes, this was all very, very exciting!**

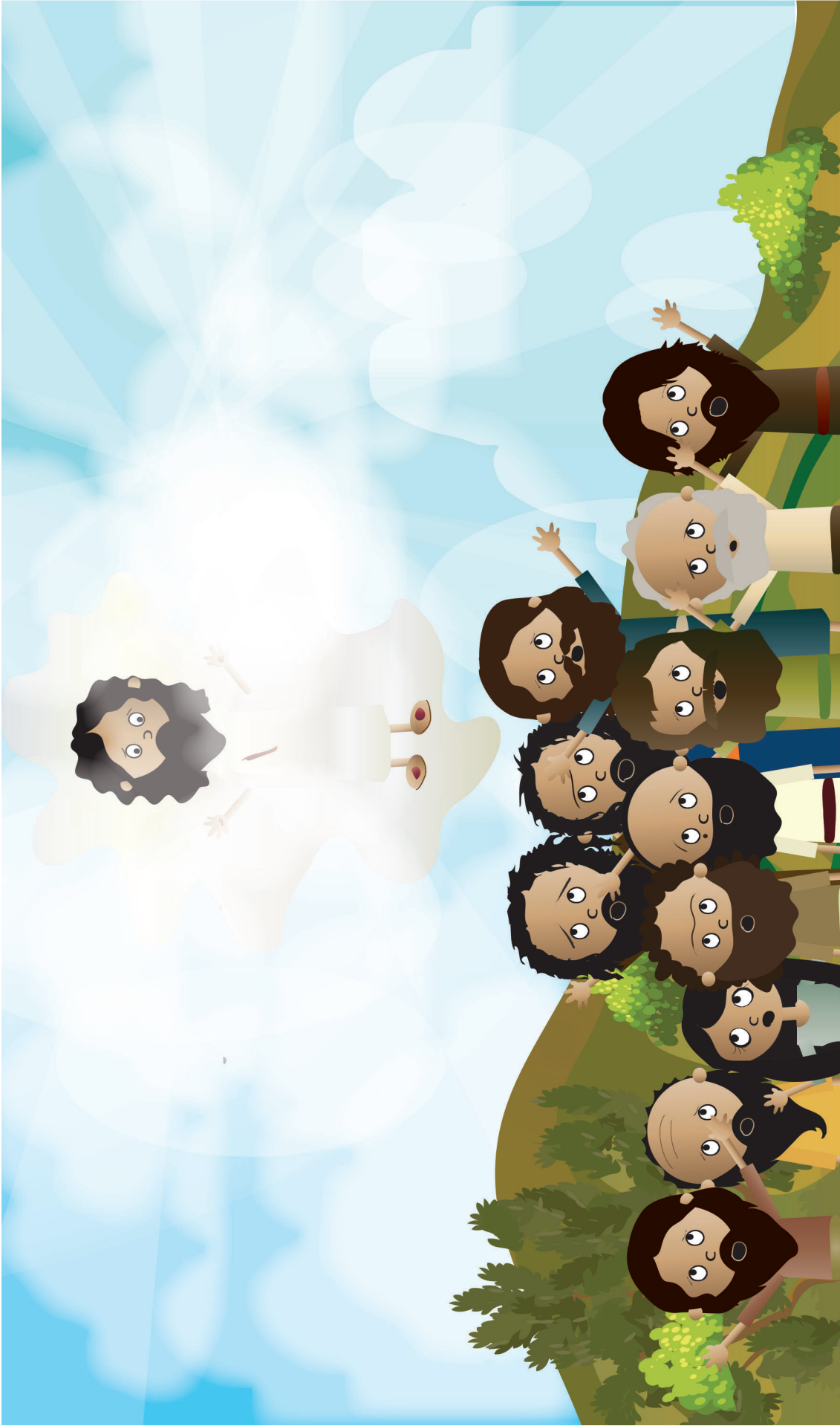

6. When Jesus finished saying all these things, He went up through the clouds to heaven. The disciples were sad for Jesus to leave them, but they were happy about His promises. How exciting! The Holy Spirit would live inside their hearts! They would get to tell everyone the good news about Jesus. And one day, when their job was finished, Jesus would come back! Yes, this was all very, very exciting!

**7. But what should they do first? Where should they go?**

**“Start in Jerusalem. Wait there for the gift of the Holy Spirit there!”  
Jesus told them; so, that’s just where they went and what they did!  
They waited and prayed until God’s Holy Spirit came to live inside  
them, just as Jesus promised.**



**7. But what should they do first? Where should they go? “Start in Jerusalem. Wait there for the gift of the Holy Spirit there!” Jesus told them; so, that’s just where they went and what they did! They waited and prayed until God’s Holy Spirit came to live inside them, just as Jesus promised.**

**8. The disciples burst out into the streets of Jerusalem, and helped by the Holy Spirit, they spread the good news of Jesus:**

**“Turn away from disobeying God! Trust in Jesus as your Savior!” they told all who would listen. “God will forgive your sins and make you, His people. You can know and love God in your hearts, right now. And when you die, you can live with Him and enjoy Him forever,” they promised.**

**“Believe this wonderful, good news today!” they urged everyone.**





8. The disciples burst out into the streets of Jerusalem, and helped by the Holy Spirit, they spread the good news of Jesus: "Turn away from disobeying God! Trust in Jesus as your Savior!" they told all who would listen. "God will forgive your sins and make you, His people. You can know and love God in your hearts, right now. And when you die, you can live with Him and enjoy Him forever," they promised. "Believe this wonderful, good news today!" they urged everyone.

**9. The Holy Spirit began to work in the hearts of many that day.  
And guess what happened next?**

**They turned away from their sins and trusted in Jesus as their  
Savior. Yay!**



9. The Holy Spirit began to work in the hearts of many that day. And guess what happened next? They turned away from their sins and trusted in Jesus as their Savior. Yay!

**10. Thousands of new believers joined Jesus' first disciples.**

**They gathered together as a church to pray and learn from God's Word. They encouraged each other to love God and love one another like sisters and brothers.**

**And, they encouraged each other to do the job Jesus gave them.  
Can you remember what that job was?**

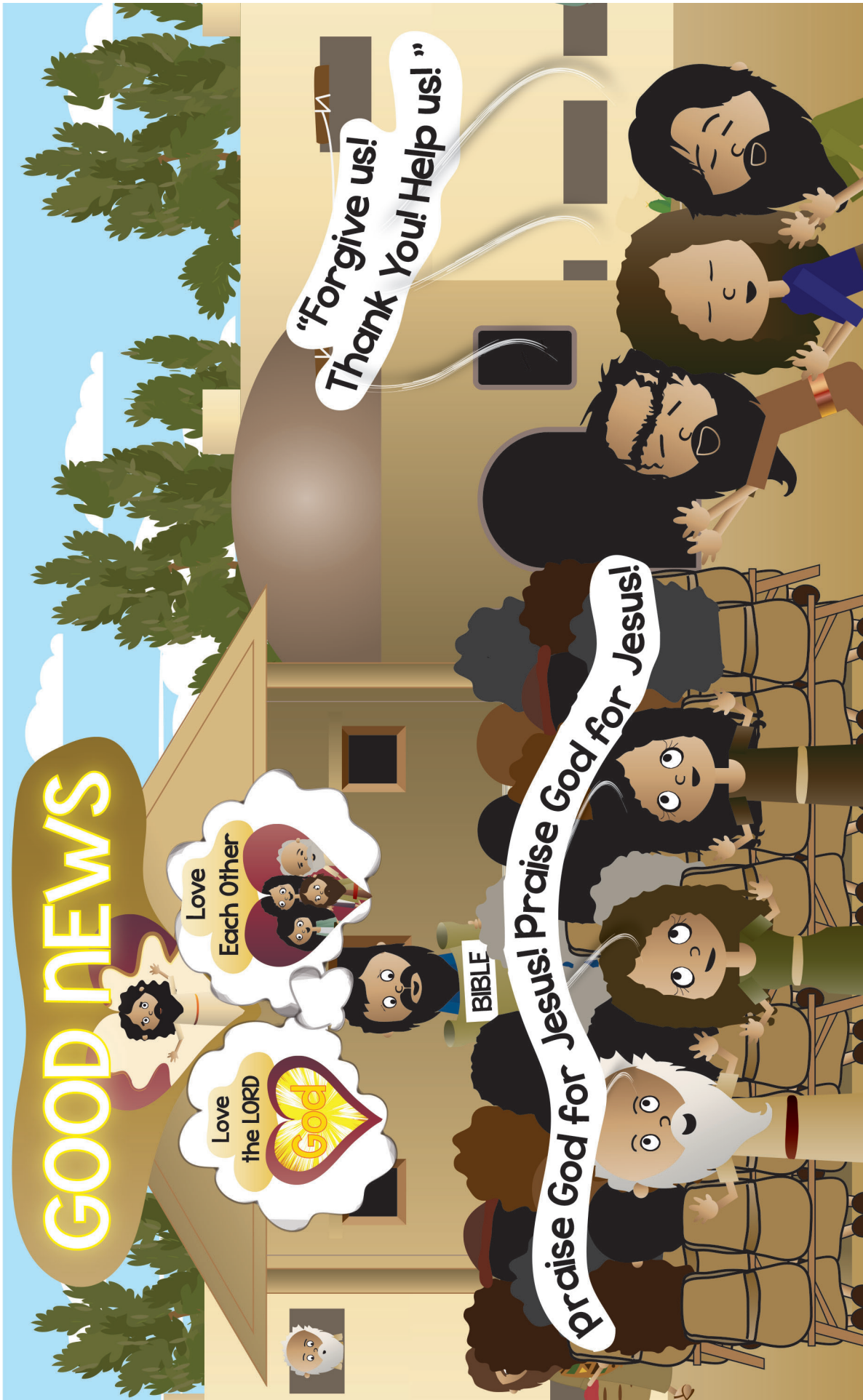

10. Thousands of new believers joined Jesus' first disciples. They gathered together as a church to pray and learn from God's Word. They encouraged each other to love God and love one another like sisters and brothers. And, they encouraged each other to do the job Jesus gave them. Can you remember what that job was?

**II. “Be My witnesses! Tell the whole world about Me!” Jesus had told them. Now, it was time to do it!**

**Some stayed in Jerusalem. They kept on telling others the good news of Jesus there.**

**But many others left Jerusalem. Jesus had told them to go to the whole world, so that’s what they did. Some went to the little towns of their homeland, Judea.**

**And what did they remember as they moved? Jesus’ last words: “Be My witnesses! Tell the whole world the wonderful, good news of salvation through faith in Me.”**



II. **“Be My witnesses! Tell the whole world about Me!”** Jesus had told them. Now, it was time to do it! Some stayed in Jerusalem. They kept on telling others the good news of Jesus there. But many others left Jerusalem. Jesus had told them to go to the whole world, so that’s what they did. Some went to the little towns of their homeland, Judea. And what did they remember as they moved? Jesus’ last words: **“Be My witnesses! Tell the whole world the wonderful, good news of salvation through faith in Me.”**

**12. And so, they did.**

**“Turn away from disobeying God and trust in Jesus as your Savior,” they told people in Judea. “God will forgive your sins and make you, His people. You can know and love God in your hearts, right now. And when you die, you will live with Him and enjoy Him forever. Believe this wonderful, good news today!” they urged the people in Judea.**

**Many heard this wonderful, good news and believed! Now, they were God’s people, brothers and sisters through Jesus!**



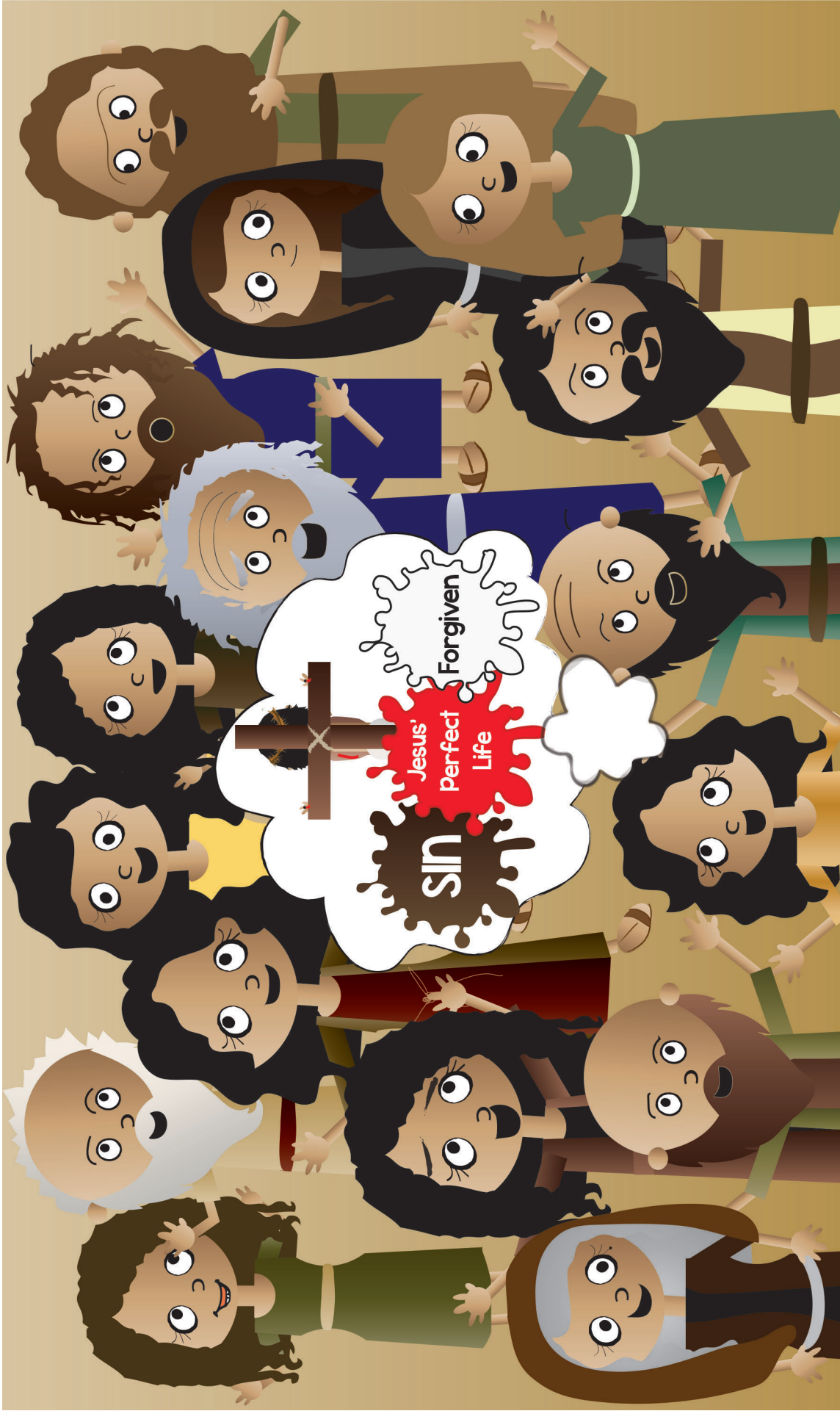

12. And so, they did. "Turn away from disobeying God and trust in Jesus as your Savior," they told people in Judea. "God will forgive your sins and make you, His people. You can know and love God in your hearts, right now. And when you die, you will live with Him and enjoy Him forever. Believe in this wonderful, good news today!" they urged the people in Judea. Many heard this wonderful, good news and believed! Now, they were God's people, brothers and sisters through Jesus!

**13. Some of Jesus' followers left Judea and went even farther away. Some, like Philip, went to Samaria, the nearby land of their enemies.**

**And what did Philip and the others remember as they went? Jesus' last words. Can you remember them? "Be My witnesses! Tell the whole world the wonderful, good news of salvation through faith in Me!" Jesus had told them.**



13. Some of Jesus' followers left Judea and went even farther away. Some, like Philip, went to Samaria, the nearby land of their enemies. And what did Philip and the others remember as they went? Jesus' last words. Can you remember them? "Be My witnesses! Tell the whole world the wonderful, good news of salvation through faith in Me!" Jesus had told them.

**14. So, that's what Philip and others did: "Turn away from disobeying God and trust in Jesus as your Savior," they told their enemies in Samaria. "God will forgive your sins and make you, His people. You can know and love God in your hearts, right now. And when you die, you will live with Him and enjoy Him forever. Believe this wonderful, good news today!" they urged.**

**Many of these enemies heard and believed! They weren't enemies, anymore! Now, they were God's people, brothers and sisters through Jesus!**



14. So, that's what Philip and others did: "Turn away from disobeying God and trust in Jesus as your Savior;" they told their enemies in Samaria. "God will forgive your sins and make you, His people. You can know and love God in your hearts, right now. And when you die, you will live with Him and enjoy Him forever. Believe this wonderful, good news today!" they urged. Many of these enemies heard and believed! They weren't enemies, anymore! Now, they were God's people, brothers and sisters through Jesus!

**15. Others, like Paul and Barnabas, went even farther away.**

**They sailed on ships over the wavy seas to islands. They walked miles and miles to other faraway places. Over tall mountains, down deep valleys, along the seashore, they travelled. Wherever people were, they went.**

**And what did they remember as they went to all these places? Jesus' last words. Can you remember them? "Be My witnesses! Tell the whole world the wonderful, good news of salvation through faith in Me!" Jesus said.**



15. Others, like Paul and Barnabas, went even farther away. They sailed on ships over the wavy seas to islands. They walked miles and miles to other faraway places. Over tall mountains, down deep valleys, along the seashore, they travelled. Wherever people were, they went. And what did they remember as they went to all these places? Jesus' last words. Can you remember them? "Be My witnesses! Tell the whole world the wonderful, good news of salvation through faith in Me!" Jesus said.

**16. So, that's what Paul and Barnabas did: "Turn away from disobeying God and trust in Jesus as your Savior," they told the peoples in those faraway places. "God will forgive your sins and make you, His people. You can know and love God in your hearts, right now. And when you die, you will live with Him and enjoy Him forever. Believe this wonderful, good news today!" they urged.**

**Many in these faraway places heard this wonderful, good news and believed! Now they were God's people, brothers and sisters through Jesus!**





16. So, that's what Paul and Barnabas did: "Turn away from disobeying God and trust in Jesus as your Savior," they told the peoples in those faraway places. "God will forgive your sins and make you, His people. You can know and love God in your hearts, right now. And when you die, you will live with Him and enjoy Him forever. Believe this wonderful, good news today!" they urged. Many in these faraway places heard this wonderful, good news and believed! Now they were God's people, brothers and sisters through Jesus!

**17. Many years have passed since Jesus told His disciples to tell the world how He can be their Savior. And all this time, as His disciples have kept on spreading the good news, the Holy Spirit has been at work in the hearts of people.**

**Now, millions, even billions, of people have become God's people, brothers and sisters through Jesus. But did you know the job is STILL not finished? There are still so many people who need to hear the good news of Jesus. Million, even billions, of people. Who will tell THEM about Him?**

# God's Son, Jesus, the Savior



17. Many years have passed since Jesus told His disciples to tell the world how He can be their Savior. And all this time, as His disciples have kept on spreading the good news, the Holy Spirit has been at work in the hearts of people. Now, millions, even billions, of people have become God's people, brothers and sisters through Jesus. But did you know the job is **STILL** not finished? There are still so many people who need to hear the good news of Jesus. Million, even billions, of people. Who will tell **THEM** about Him?

**18. God's people, living today, that's who! Jesus wants His disciples to keep on telling everyone, all over this world, how He can become their Savior.**

**People who live near them need to hear. People who live far away from them need to hear. And everyone who lives in between needs to hear, too! They ALL need to hear the wonderful, good news of Jesus, that they might turn away from disobeying God, trust Jesus as their Savior, and be saved!**



18. God's people, living today, that's who! Jesus wants His disciples to keep on telling everyone, all over this world, how He can become their Savior. People who live near them need to hear. People who live far away from them need to hear. And everyone who lives in between needs to hear, too! They ALL need to hear the wonderful, good news of Jesus, that they might turn away from disobeying God, trust Jesus as their Savior, and be saved!

**19. And who will help God's people finish this big job?**

**The same person who helped those believers, long ago. God's Holy Spirit, that's who! He is living in their hearts, helping God's people do the job Jesus gave them.**

**He's at work in those who hear the good news of Jesus, too, helping them turn away from their sins and trust in Jesus as their Savior.**



19. And who will help God's people finish this big job? The same Person who helped those believers, long ago. God's Holy Spirit, that's who! He is living in their hearts, helping God's people do the job Jesus gave them. He's at work in those who hear the good news of Jesus, too, helping them turn away from their sins and trust in Jesus as their Savior.

**20. On and on, God's people will remember Jesus' last words to them: "Be My witnesses! Tell the whole world the wonderful, good news of salvation through faith in Me!" Jesus said.**

**Yes, they will keep on doing the job God gave them, until all of God's people are saved, millions and billions, even trillions of people. More people than we can count. Wow!**

**And THEN, at last, it will be time for Jesus to come back. He will take His people to live with Him in the new heaven and earth forever. What a great day that will be! It will be perfect Wonderfulness!**





## Perfect Wonderfulness

20. On and on, God's people will remember Jesus' last words to them: "Be My witnesses! Tell the whole world the wonderful, good news of salvation through faith in Me!" Jesus said. Yes, they will keep on doing the job God gave them, until all of God's people are saved, millions and billions, even trillions of people. More people than we can count. Wow! And THEN, at last, it will be time for Jesus to come back. He will take His people to live with Him in the new heaven and earth forever. What a great day that will be! It will be Perfect Wonderfulness!

## DDD 12.7 Simple Story Scenes

# “The Case of the Beautiful, Busy Feet” Acts

## SOLVED

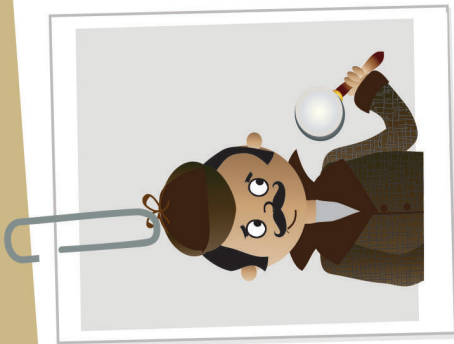

### Detective Dan's Listening Assignment #1

1. Who had beautiful, busy feet?  
God's people.
2. What made the feet beautiful? What were they busy doing?  
They were using their feet to travel to faraway places to tell others about Jesus. People turned away from their sins and trusted in Jesus as their Savior. They became God's people, too. They were so grateful that someone would walk so far just so they could hear about Jesus. That's why they called the feet of these messengers beautiful!

**For You and Me:**  
Jesus' first followers were busy going into the world, telling everyone about Jesus. They wanted everyone to turn away from their sins and trust in Jesus as their Savior. They wanted them all to be God's people forever. Jesus still sends out His followers so that many more people might trust in Him as their Savior. Why, your teachers, even today, are telling you this good news, so that YOU might turn away from your sins and trust in Jesus as your Savior. They want you to be God's people too. I guess that means they have beautiful feet!

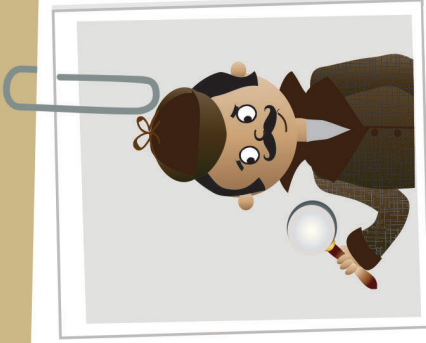

### Detective Dan's Listening Assignment #2

Romans 10:13,15, ESV

“Everyone who calls on the name of the Lord will be saved.” ... As it is written, “How beautiful are the feet of those who preach the good news!”

1. What message about Jesus did Jesus' followers tell everyone?  
That they could become God's people when they turned away from their sins and trusted in Jesus as their Savior.
2. Why were their feet so busy traveling to faraway places to tell everyone this message?  
Only by going to these faraway places would the people who lived there hear about Jesus, turn away from their sins, and be saved. This was the only way they could get to become God's people.

**For You and Me:**

Jesus' first followers were busy going into the world, telling everyone about Jesus. They wanted everyone to turn away from their sins and trust in Jesus as their Savior. They wanted them to be God's people forever. Jesus still sends out his followers today. He still wants people to trust in Him as their Savior. Why, your teachers, even today, are telling you this good news so that YOU might turn away from your sins and trust in Jesus as your Savior. They want you to be God's people too. I guess that means they have beautiful feet, too!

## DDD 12.7 Simple Story Scenes

How Should God's People Live?  
They Should Live Like Jesus...  
By Telling the Good News of Jesus!

# The Gospel

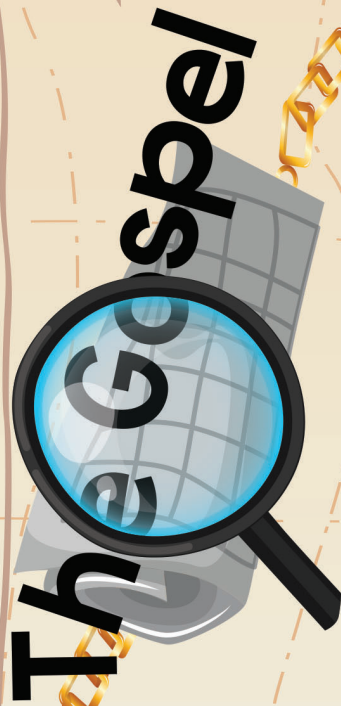

God is the good Creator and King over everything. He gave us His good laws to live by. Yet, we have all chosen to disobey Him and His good ways. And now, we all deserve His punishment. This bad news is why it's so important to tell the good news of Jesus to the whole world!

You see, God chose to send His Son, Jesus, to be the Savior. Jesus lived a perfect life. Then, on the cross, He gave it as the full payment for the sins of God's people. On Day Three, Jesus rose from the dead. He had really beaten sin and death for them.

Now, all who turn away from their sins and trust in Jesus as their Savior can be God's people. This is how we can become God's people, too. Ask Him to help you

do this. He loves to answer this prayer!

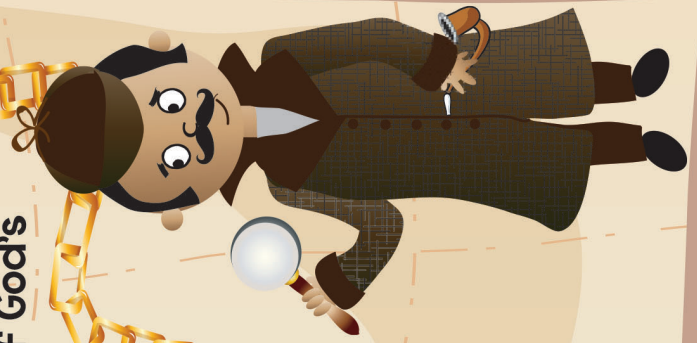

## DDD 12.7 Simple Story Scenes

# A Prayer

A God, we praise You for being the God who saves. You made the way for sinful people like us to become Your people. How loving and merciful You are!

C God, please forgive us for not telling others about You as You want us to. Forgive us for being scared that others might not want to hear about Jesus or make fun of us. Forgive for not trusting You to be at work as we share the good news about salvation through Him. We need a Savior!

T Thank You, God, for offering to make us Your people through Jesus. Thank You for giving us the wonderful, good news of salvation through Him.

S God, please work in our hearts. Help us turn away from our sins and trust in Jesus as our Savior. Help us to tell others how they can receive the free gift of salvation through Him, too. Work inside others as they hear about Jesus and help them believe in Him, too.

In Jesus' name we pray. Amen.



### DDD 12.7 Simple Story Scenes



# **DEEP DOWN DETECTIVES**



**Visual Aids**

**Unit 12,**

**Bible Truth 8**

## About the Deep Down Detectives Visual Aids

### How Are They Used?



The Deep Down Detectives Visual Aids book is a companion resource to be used alongside the Deep Down Detectives Core Curriculum book for each unit. These colorful pictures are used in presenting the key concepts; telling the Bible stories; and, in playing the Bible Story Review games.

### What Do They Include?



**There are four different resources included in this book:**

- 1. Key Concept Visual Aids**-- colorful signs of the Big Question and Answer, the Bible Truth, the Bible verse, and the Listening Assignments to use with the 3 lessons for each Bible Truth.
- 2. The Story Scenes.** Notice that each scene is numbered and that there is a brief summary of the story that corresponds to the picture. You can actually just tell the story in a simple way by using only the text at the bottom of each Story Scene.
- 3. Directions** for making the Deep Down Detectives "Bible" Folder and the **back/front images** to paste in place when making it. (Larger back/front images are found online with the curriculum.)
- 4. Directions** for how to make a homemade flannelgraph storyboard and sturdy Story Scene pictures are found in the back of this book.

### Ready, Set, Rip It Out!

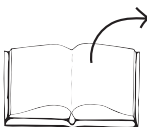

This book is meant to be ripped up and made into your visual aids. The key concept signs can be cut out and laminated or slipped into sheet protectors. The Story Scenes can be put in sheet protectors or laminated, too.

### Store It!



Deep Down Detectives is a curriculum that can be used over and over. Store your visual aids and storyboard pictures after using them and they will serve you for many years. We store ours in manilla envelopes and then put them (along with all the rest of the curriculum) in magazine files, labelled by Bible Truth. If you have multiple classes using the curriculum, store each set of resources in separate manilla envelopes. This will make prep much simpler, second time around.

### Replacement Story Scene Pictures



You can always purchase this book again or simply go online and print out any scenes that go missing.

### Other Options



You can also choose to tell the story in a more traditional flannelgraph way by using your own flannelgraph figures or by purchasing/free downloading the Storyboard Pictures (large and small format size available). This is more complex and requires more preparation, but some love it. And, it does allow for kids to interact more by helping to place pictures up on the board as you tell the story.

**Unit 12: God's People Live for Him**

**Unit Big Question (and Answer):** How Should God's People Live? They Should Live Like Jesus!

**Unit Bible Verse:** "Be imitators of God, as beloved children. And walk in love, as Christ loved us and gave himself up for us." --Ephesians 5:1-2, ESV

**Bible Truth 8 Concept: They Should Live Like Jesus...By Making Much of God!**

There are many things we delight in. Birthdays and Christmas. Learning to ride a bike or how to read. Even beautiful things, like the soft, fluffy snow and colorful rainbows. God's people delight in these things, too. But do you know what (or really WHO) God's people delight in most of all? It's the same person Jesus delighted in most of all... God!

Yes! Like Jesus, God's people want to delight in God most of all. They want their lips to be full of praise for Him, and their lives to be pleasing to Him. They want to tell others how good and loving and powerful God is.

And they don't want others just to HEAR how amazing God is. They want others to BE His people, too, so they can KNOW God and DELIGHT in how amazing He is, themselves. They want the whole world to delight in God, because God is the most wonderful person we can ever know. And, because it pleases God when we make much of Him, the one, true God.

The big, Bible word for making much of God is "glorify." Jesus glorified God with His whole life—in everything He thought, and said, and did. God's people ask God to help them glorify Him, too. We can glorify God, too, when we turn away from our sins, trust in Jesus as our Savior, and live our lives for Him. This is how we become God's people. Let's make much of God!

**Bible Truth 8 Bible Verse: Psalm 66:1-3,5,16, NIV 1984**

"Shout with joy to God, all the earth! Sing the glory of His name! Say to God, "How awesome are your deeds! Come and see what God has done... Let me tell you what he has done for me."

**Learn a Little:** "Shout with joy to God, all the earth! Sing the glory of His name!"

**Meaning**

God's people delight in God's glory. He has been so good to them! He has given His Son to save them from their sins. He has provided for their needs with what He knows is best for them. He has filled them with His Holy Spirit, and they have fellowship with Him in their heart. They have never lacked any good thing and they never will their whole life. They want to praise the LORD all the time. They want others to join them in magnifying His name (praising Him) and in knowing Him, themselves. To be one of God's people is the best blessing anyone can ever have.

**Bible Truth 8 ACTS Prayer**

- A** God, we praise You. You are perfect, good, loving, and wise. You deserve all our praise.
- C** God, please forgive us for choosing to not praise You or delight in You, as You deserve. Many times, we choose to make much of ourselves or others, instead of You. We need a Savior!
- T** Thank You, God, for sending Jesus to save us from our sins. He alone is Savior. He deserves for us to make much of Him.
- S** God, please work in our hearts. Help us turn away from our sins and trust in Jesus as our Savior. Help us to make much of You. Help us to delight in You and how wonderful You are.

In Jesus' name we pray, Amen.

**Bible Truth 8 Story**

**The Case of the Boastful Man**    *Acts 7-9,22; Romans; 1 & 2 Corinthians; Ephesians; Philippians*

**Songs Used in Bible Truth 8**

Big Q & A 12 Song

Big Question 12 Song: How Should God's People Live?

Big Question 12 Bible Verse Song: Walk in Love    Ephesians 5:1-2, ESV

*Extra Big Question 12 Bible Verse Song: Let Everyone Who Names the Name*    2 Timothy 2:19,22, ESV

Big Question 12 Hymn: Trust and Obey, v.1

Big Question 12 Praise Song: I Have Decided to Follow Jesus

Bible Truth 8 Bible Verse Song: Shout with Joy to God    Psalm 66:1-3,5,9,16, ESV

*Extra Bible Truth 8 Bible Verse Song: As Each Has Received a Gift*    1 Peter 4:10-11, ESV

*Extra Bible Truth 8 Bible Verse Song: Gift, Gift, Gift*    1 Peter 4:10-11, ESV

*Extra Bible Truth 8 Bible Verse Song: I Will Bless the Lord at All Times*    Psalm 34:1,3,8,10, ESV

*listen to or download songs for free at <https://praisefactory.org>: Deep Down Detectives Music page*

**The Case of the Boastful Man***Acts 7-9,22; Romans; 1 & 2 Corinthians; Ephesians; Philippians***Story-telling Tips**

Ahead of time:

1. Read the Bible verses and story. Pray!
2. Choose story action cues and prepare storyboard figures/story scenes, if using. (In Visual Aids book)
3. Practice telling story with the storyboard pictures, timing your presentation. Shorten, if necessary.

During your presentation:

1. Maintain as much eye contact as possible as you tell the story.
2. Put up storyboard figures/add story action cues/hold up storybook scenes as you tell the story. Allow the children to help you put them on the board, if desired.
3. Include the children in your story with a few questions about what they think will happen or words/concepts that might be new to them.
4. Watch the kids for signs that their attention span has been reached. Shorten, if necessary.

**INTRODUCTION/ LISTENING ASSIGNMENTS**

**"Our story is called: The Case of the Boastful Man. Here is your listening assignment."** Read from Detective Dan's Listening Assignment signs, but questions are summarized below:

**Detective Dan's Lesson #1 Listening Assignment:**

I need to find out:

1. Who was the man who was boastful? Who did he first boast about?
2. Why did he change his boast? Who did boast in, instead?

**Detective Dan's Lesson #2 Listening Assignment:****Our Bible Verse is Psalm 66:1-3,5,16, NIV 1984:**

"Shout with joy to God, all the earth! Sing the glory of His name! Say to God, "How awesome are your deeds! Come and see what God has done... Let me tell you what he has done for me."

I need to find out:

1. Who changed from being a man who boasted about himself to a man who boasted about God?
2. What awesome deed of God did he especially love to boast about?

**Detective Dan's Lesson #3 Listening Assignment:**

I found six clues, but only 4 of them are in the story.

They are: a star, God's law, a shoe, a Pharisee, the cross, wild animal.

*Hold each of them up for the children to see as you identify them.*

I need to figure out:

1. Which four belong in our story?
2. Who did Paul boast in most of all? Why did he boast in Him so much?

**Read the assignment questions, THEN SAY,**

"Ok, Deep Down Detectives! Put on your best listening ears and see if you can hear the answers to Detective Dan's questions. When I finish telling the story, we will see if we can answer all the questions."

*Read the Bible Truth story, answer questions, present the gospel and lead in prayer.*

*Answers to questions; the gospel; and, ACTS prayer are included with the story text.*

**The Case of the Boastful Man** *Acts 7-9,22; Romans; 1 & 2 Corinthians; Ephesians; Philippians*

*Story with lines separating paragraphs (text in bold, optional interaction cues in italics)*

---

**Paul was a man who was always boasting. What is boasting? It's telling how great someone is to others. Now, some people boast in themselves, and some people boast in others. Many times, boasting is bad, especially when we boast about ourselves. But some boasting is good when we boast about the right person. Paul started out as a bad boaster, but he became a good boaster. Can you guess who Paul learned to boast in?**

*Can you guess who?*

**It was the LORD! Yes, Paul loved to make much of the one, true God!**

---

**"Some might think I have a lot to boast about MYSELF. I certainly used to think I did," Paul told people. "After all, I was born in an important city as a Roman. I enjoyed lots of nice things and was treated as someone special. That sounds like a lot to boast about, doesn't it?" Paul explained.**

---

**"My parents were good Jews. I grew up learning God's Word and obeying it. That sounds like a lot to boast about, too, doesn't it?" Paul told people.**

---

**"I was really, really smart. I went to the school for smart boys in the big city of Jerusalem. I had great teachers like Gamaliel to teach me. That sounds like something else I could boast about," Paul said.**

---

**"I stayed in school a long time. I was one of the best students. I became a Pharisee. I became very good at knowing God's laws and keeping all of the teachers' extra, little rules. I was better than others at keeping them. I thought I pleased God by being a good law-keeper," Paul told them. "Oh, I thought I had so much to boast in!" he exclaimed.**

---

**"But I was wrong," Paul sadly said. "I had nothing to boast about. I was just like everyone else. I was just like everyone else. My heart was full of sin. I was a lawbreaker, not a law-keeper. I could never really please God by obeying laws and rules," Paul confessed. "I did some terrible things. I hated Jesus and told everyone that He was a fake Savior. I hunted down His followers. I had them hurt and put in jail. I was even happy if they died! I thought these things pleased God. But I was so wrong. So terribly wrong!" Paul exclaimed.**

---

**"No, I had nothing to boast about at all. I deserved God's punishment for my sins! I could never please Him on my own," Paul admitted.**

**"But do you know what? God saved me from my sins, and He made me one of His people!" Paul said.**

*Can you guess how God saved Paul?*

**Through Jesus!**

**"Yes, God saved me through His Son, Jesus!" Paul exclaimed. "He forgave me—yes, even me, the worst of sinners! What a wonderful Savior He is!" Paul said. "And that's why I love to boast about God. That's why I want to do anything for Him. I want to make much of God because of what He's done for sinners like me!"**

*Story with lines separating paragraphs (text in bold, optional interaction cues in italics)*

---

**So, for the rest of his life, in everything he did, and everything he said, to EVERYONE he met, Paul boasted about the LORD. There was never a time when Paul could not think of a way to make much of God!**

---

Sometimes, Paul traveled to big cities and talked to smart people who thought believing in Jesus was silly. Paul boasted in God to them: "You may think believing in Jesus is silly, but God's silliness is smarter than all your smartness! Jesus really IS God's Son! Turn away from your sins. Trust in Him as your Savior, and be saved!" he urged them. WHO was Paul making much of when he talked to these smart people?

*Can you tell me?*

**He was making much of the LORD! He loved to tell everyone how great is the one, true God!**

---

Sometimes, Paul talked to people who hurt him and threw him in jail when he told them about Jesus. But Paul boasted in God to them: "I don't like to be hurt or be put in jail, but Jesus suffered far more than this for me. He suffered and died for my sins on the cross. He can forgive your sins, too, if you turn away from disobeying God and trust in Jesus as your Savior," Paul told them. "I am happy to suffer for Him who suffered so much for me, especially if it helps you to believe in Him, too!" he said. WHO was Paul was making most of when he thought about his suffering?

*Can you tell me?*

**He was making much of the LORD! He loved to tell everyone how great is the one, true God!**

---

Sometimes, Paul preached to God's people who gathered at a worship house to hear God's Word. Paul read the Bible to them and showed them all God's promises about Jesus. "How great God is! He planned all along to send Jesus to save His people. God put it here in the Bible for us to read and to help us believe," Paul told them. WHO was Paul making much of when he preached God's Word?

*Can you tell me?*

**He was making much of the LORD! He loved to tell everyone how great is the one, true God!**

---

Sometimes, Paul was weak and sick. His eyes hurt and he could hardly write. "God always makes me strong to do whatever He wants me to do. When I am weak, He can show everyone how strong He is!" Paul boasted. WHO was Paul making much of when he talked about his weakness?

*Can you tell me?*

**He was making much of the LORD! He loved to tell everyone how great is the one, true God!**

---

Paul faced death many times. Once, at the teeth of wild animals; and another time, out on a sinking boat on stormy seas. Paul boasted in God then, too. "God can even rescue me from the teeth of wild animals. He can even save me out in the stormy seas. There is nothing He can't do," Paul said. And sure enough, God DID save him!

**WHO was Paul making much of, even in these very scary times?**

*Can you tell me?*

**He was making much of the LORD! He loved to tell everyone how great is the one, true God!**

*Story with lines separating paragraphs (text in bold, optional interaction cues in italics)*

---

**“And when I DO die,” Paul told people, “(SB18) God will take me to live with Him forever in heaven. Through Jesus, God has already beat sin and death for me! Going to live with Him will be best of all!” Paul exclaimed. WHO was Paul making much of, even when he talked about dying?**

*Can you tell me?*

**He was making much of the LORD! He loved to tell everyone how great is the one, true God!**

**Yes, no matter what Paul went through, no matter who he talked to, Paul boasted in the LORD. He loved to make much of God!**



**Cracking the Case:** (story wrap-up for Listening Assignments)

It's time to see how we did with our Listening Assignment.

**Detective Dan's Lesson 1 Listening Assignment:**

**1. Who was the man who was boastful? Who did he first boast about?** Paul. He boasted in himself and all the good things he did.

**2. Why did he change his boast? Who did boast in, instead?** He changed his boast when God showed him that he was a sinner who did not deserve to be one of God's people. He changed his boast to God and how He had forgiven his sins through Jesus.

**For You and Me:**

God has been kind to give each of us many good gifts. He has made us able to do many good things. Sometimes, we might want to boast about the good things we can do. But like Paul, God wants us to boast only in Him. He is the giver of all those good gifts; and, He is the only one who can forgive our sins through Jesus. We need Him to do that most of all! That's why Paul made much of God. And, that's what God wants us to do, too. He wants us to turn away from our sins and trust in Jesus as our Savior. He wants us to praise Him for being our God and for being so good to us. Ask Him to help you do this. He loves to answer this prayer!

**Detective Dan's Lesson 2 Listening Assignment:**

**Our Bible Verse is Psalm 66:1-3,5,16, NIV 1984:**

"Shout with joy to God, all the earth! Sing the glory of His name! Say to God, "How awesome are your deeds! Come and see what God has done... Let me tell you what he has done for me."

**1. Who changed from being a man who boasted about himself to a man who boasted about God?** Paul did.

**2. What awesome deed of God did he especially love to boast about?** For forgiving his sins through Jesus.

**What about you and me?**

God gives the whole earth reason to shout for joy. He gives the whole earth reason to glory in his name. Everywhere are God's awesome deeds in the earth. More than anyone else, God's people love to make much of God and all of the good things He has done. After all, He has saved from their sins and made them His dearly-loved people forever. We can become God's people, too, when we turn away from our sins and trust in Jesus as our Savior. Then like the rest of God's people, we will have so very much to boast in God about!

**Detective Dan's Lesson 3 Listening Assignment:**

Our six clues were: a star, God's law, a shoe, a Pharisee, the cross, wild animal.

**1. Which four belong in our story?**

God's law, the Pharisee, the cross and the wild animal belong. The star and the shoe do not.

**2. Who did Paul boast in most of all? Why did he boast in Him so much?** He boasted in God. Because God had forgiven his sins and saved him through Jesus, when he never, ever deserved it.

**For You and Me:**

What a great work God did in Paul's heart! He had been a man who boasted in how well he could keep God's laws. God changed him into a man who knew that only through Jesus that he could ever please God and become one of His people. Paul was so grateful to God for saving him! God can save us, too, when we turn away from our sins and trust in Jesus as our Savior. Then, what a lot we will have to be grateful to God for, too!

**The Gospel** (story wrap-up if NOT using Listening Assignments)**Our Bible Truth is:**

**How Should God's People Live?**

**They Should Live Like Jesus...**

**By Making Much of God!**

How should God's people live each day? They should live like Jesus... by making much of Him. God's people want to make much of God because of all He has done for them. He has treated them so much better than they could ever deserve. God's people, like everyone, have all chosen to disobey God. They deserved His punishment. But God sent His Son, Jesus, to live a perfect life and offer it up as He died on the cross as the full payment for their sins. On the third day, Jesus rose from the dead in victory. He had beaten sin and death for them. God's people turn away from their sins and trust in Jesus as their Savior. They get to know God in their hearts, now. And one day, go to live with God forever. We can become God's people, too, when we turn away from our sins and trust in Jesus as our Savior. And if we do, we will want to make a big deal about God's wonderful love for us!

*Close in prayer.*

**Closing ACTS Prayer**

- A** God, we praise You. You are perfect, good, loving, and wise. You deserve all our praise.
- C** God, please forgive us for choosing to not praise You or delight in You, as You deserve. Many times, we choose to make much of ourselves or others, instead of You. We need a Savior!
- T** Thank You, God, for sending Jesus to save us from our sins. He alone is Savior. He deserves for us to make much of Him.
- S** God, please work in our hearts. Help us turn away from our sins and trust in Jesus as our Savior. Help us to make much of You. Help us to delight in You and how wonderful You are.

In Jesus' name we pray, Amen.

***Go to Lesson Plan, p.9 for the script to the rest of the lesson.***

# How should God's people live?

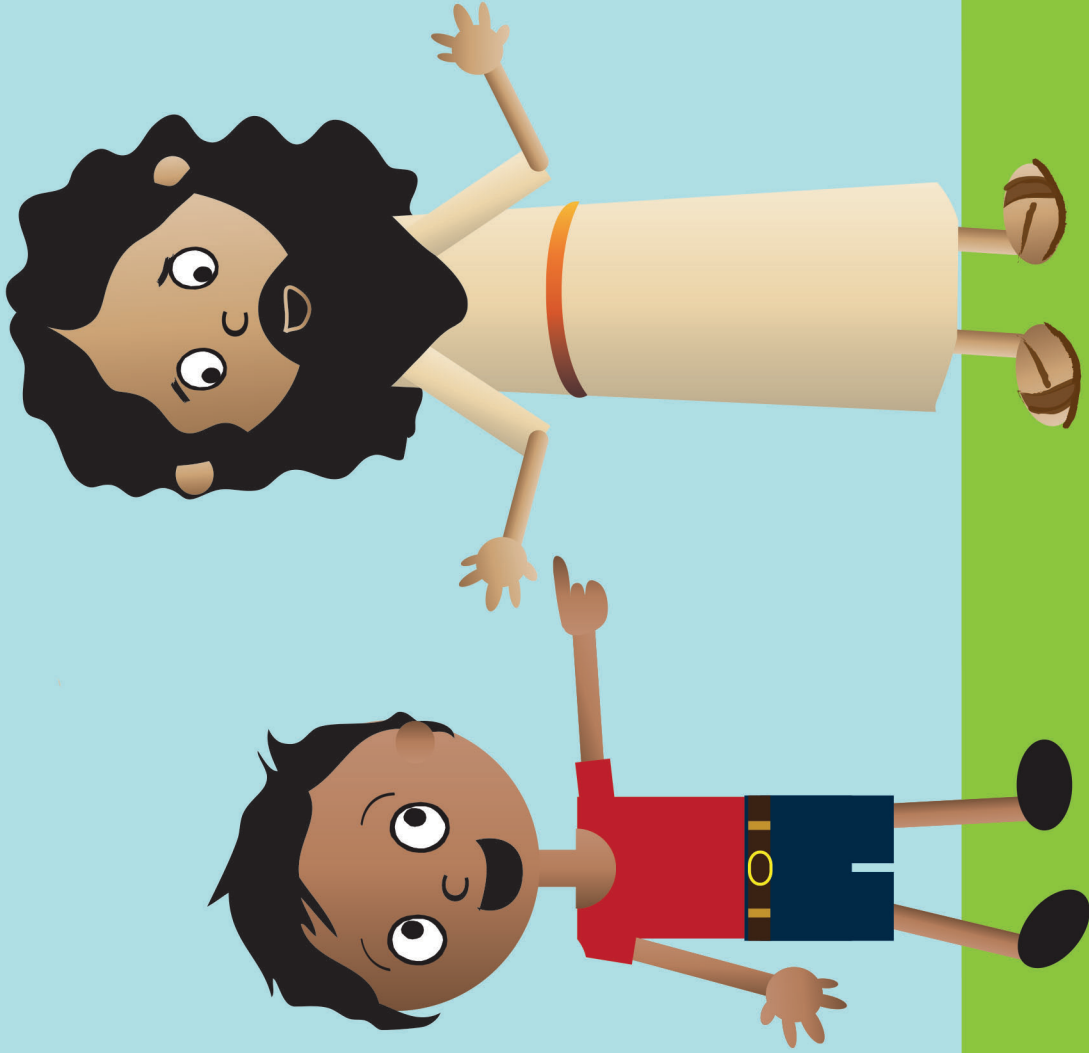

ANSWER:

**They should live like Jesus!**

VISUAL  
AID  
**#1**  
take out  
BIG  
QUESTION  
of BQB

## The Big Question

*Hold up the Big Question sign for all the children to see, and say:*

The Big Question we are investigating today is Big Question

Number 12:

**How Should God's People Live?**

and the Answer is:

**They Should Live Like Jesus!**

### **Meaning:**

We become God's people when we turn away from our sins and trust in Jesus as our Savior. When we do, God forgives our sins, and we begin a whole new way of life. God's people no longer live life just to please themselves. They want to honor God with their whole lives, like Jesus did. They seek to love God most of all and love all people, too.

Let's sing our Big Question Song: "

## Big Q & A 12 Song

*DDD ESV Songs 12, track 12*

*(adapted version of "Pop, Goes the Weasel")*

How should God's people live each day?

They should live like Jesus!

How should God's people live each day?

How should God's people live each day?

How should God's people live each day?

They should live like Jesus!

# BIG QUESTION 12: Eight truths about how God's people live

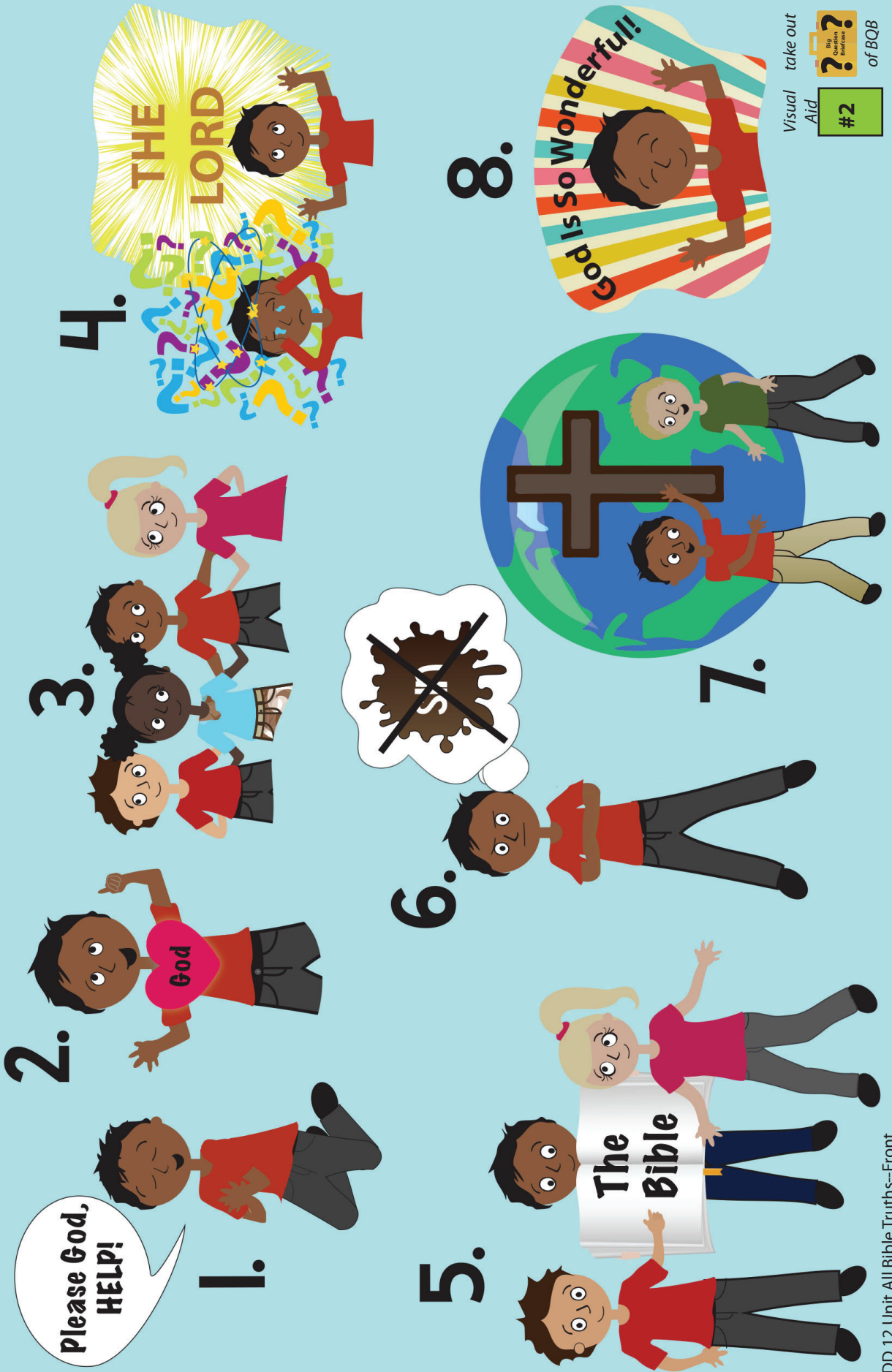

Visual take out  
Aid

#2

The Question Bible  
of BQB

## **This Unit's Bible Truths**

"They Should Live Like Jesus" is a good beginning, but there's so more to learn. So it's time for us to dig down even deeper for more answers to our Big Question about God. We're going to be learning EIGHT Bible truths that all tell us more about how God wants His people to live.

Who would like to hand me the picture with our eight Bible truths on it? It's in the Big Question Box/Briefcase."

*Choose a child to get it and hand it to you, then hold it up and show them the pictures of the eight truths they will be learning.*

*After everyone has had a good look say...*

"Ok, we've learned seven truths about how to live for God. They are: "By Asking God for His Help," "By Loving God Most of All," "By Loving Other People As God Has Loved Them," "By Trusting God and Being Happy with What He Wants," "By Learning God's Word and Obeying It," "By Saying "No" to Disobeying God," and "By Telling the Good News of Jesus." (point to pictures as you identify each Bible Truth). Now let's look at our Bible Truth Clue sign and see if we can figure out which of these eight truths we will be learning about today. Who would like to get it out of the Big Question Briefcase for me?"

*Choose a child to open the briefcase, take out the Bible Truth Clue sign and hand it to you.*

CAN YOU GUESS BIBLE TRUTH 8?

How Should  
God's People Live?  
They Should Live Like Jesus...

By making Much of ???!

HINT: Who made all things  
and is the great, good King  
who rules over it all?  
His name starts with a "G"  
and it rhymes with "odd."

ANSWER:  
By making Much of GOD!

God Is So Wonderful!

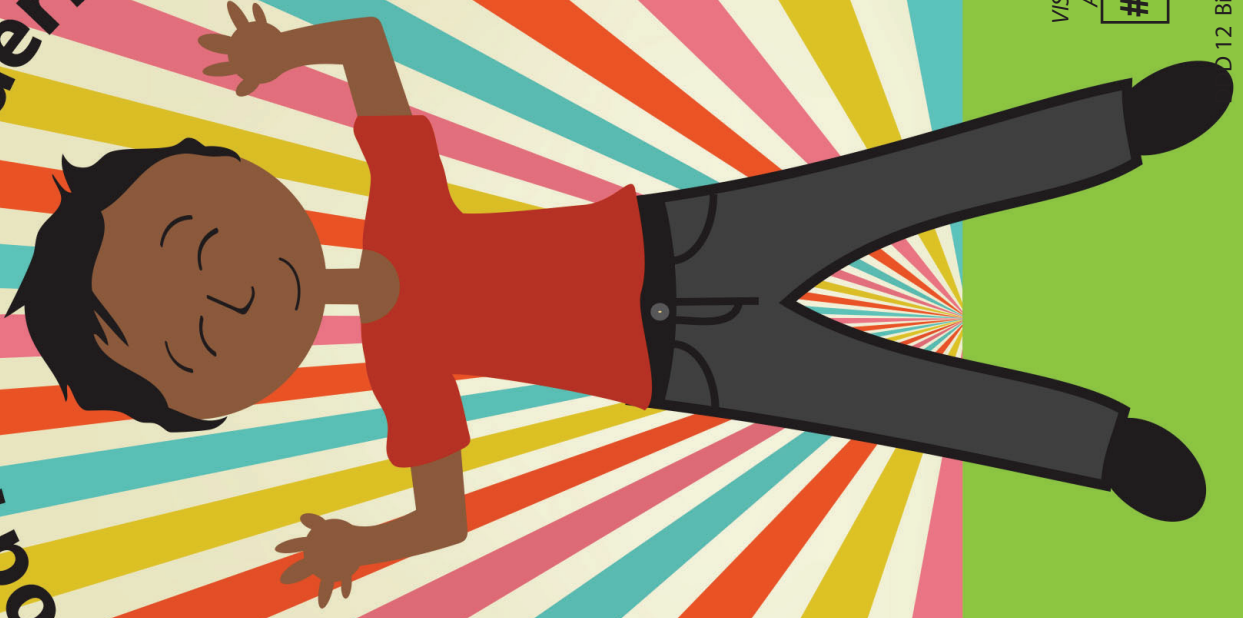

VISUAL  
AID

#1

Big  
Question  
Answers  
of BOB

# Revealing the Bible Truth We Are Learning

*Hold up the front side for the children to see. Cover up the answer, written along the bottom, and say:*

**“How Should God’s People Live?  
They Should Live Like Jesus!  
By Making Much of ?????!”**

We’re missing one word. Here’s the hint to what the missing word is. It says: “Who made all things and is the great, good King who rules over it all? His name starts with a “G” and it rhymes with “odd.”

Can you guess? It’s “GOD.”

So, the Bible Truth we are learning today is:

*(uncover answer from bottom of sign, show it to them and say:)*

**“How Should God’s People Live?  
They Should Live Like Jesus!  
By Making Much of GOD!!”**

And here is what this Bible Truth means:

*(read the meaning off of the back of the sign, say:)*

There are many things we delight in. Birthdays and Christmas. Learning to ride a bike or how to read. Even beautiful things, like the soft, fluffy snow and colorful rainbows. God’s people delight in these things, too. But do you know what (or really WHO) God’s people delight in most of all? It’s the same person Jesus delighted in most of all... God!

Yes! Like Jesus, God’s people want to delight in God most of all. They want their lips to be full of praise for Him, and their lives to be pleasing to Him. They want to tell others how good and loving and powerful God is.

And they don’t want others just to HEAR how amazing God is. They want others to BE His people, too, so they can KNOW God and DELIGHT in how amazing He is, themselves. They want the whole world to delight in God, because God is the most wonderful person we can ever know. And, because it pleases God when we make much of Him, the one, true God.

The big, Bible word for making much of God is “glorify.” Jesus glorified God with His whole life—in everything He thought, and said, and did. God’s people ask God to help them glorify Him, too. We can glorify God, too, when we turn away from our sins, trust in Jesus as our Savior, and live our lives for



Visual Aid

#4

Place verse in



take out



of BQB

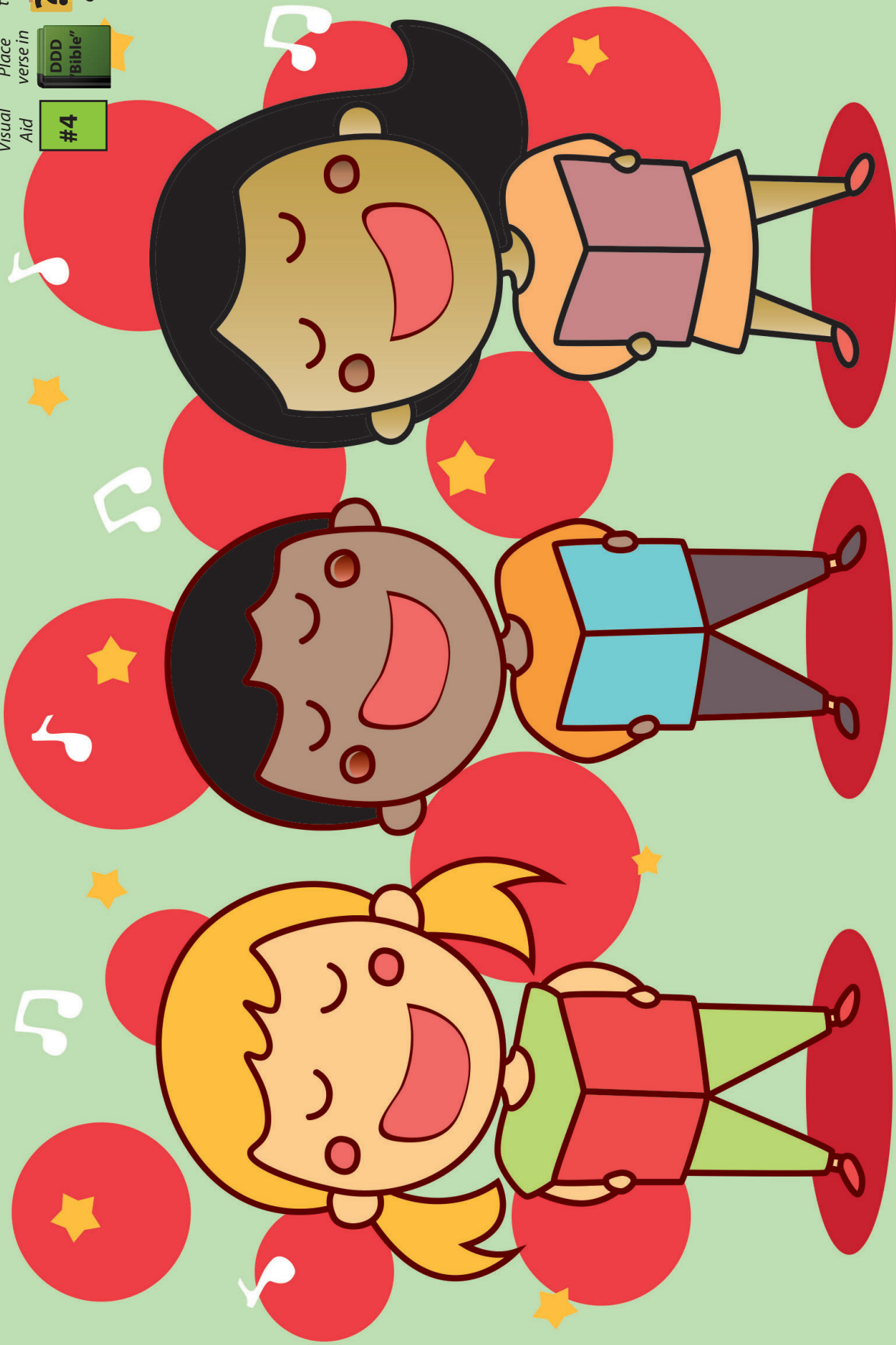

“Shout with joy to God, all the earth! Sing the glory of His name!

Say to God, “How awesome are your deeds! Come and see what God has done...

Let me tell you what he has done for me.” -- Psalm 66:1-3,5,16, NIV 1984

## Bible Truth 8 Bible Verse

*Remove the Bible Verse Picture from the "Bible" folder and hold it up for all the children to see, then say:*

Psalm 66:1-3,5,16 tells us:

### **Psalm 66:1-3,5,16, NIV 1984**

"Shout with joy to God, all the earth! Sing the glory of His name! Say to God, "How awesome are your deeds! Come and see what God has done... Let me tell you what he has done for me:"

#### **Learn a Little:**

"Shout with joy to God, all the earth! Sing the glory of His name!"

#### **What does that mean?**

God's people delight in God's glory. He has been so good to them! He has given His Son to save them from their sins. He has provided for their needs with what He knows is best for them. He has filled them with His Holy Spirit and they have fellowship with Him in their heart. They have never lacked any good thing and they never will their whole life. They want to praise the LORD all the time. They want others to join them in magnifying His name (praising Him) and in knowing Him, themselves. To be one of God's people is the best blessing anyone can ever have!

*"We've said our Bible verse, now let's sing it!"*

## Shout with Joy to God

### **Psalm 66:1-3,5,9,16**

*DDD ESV Songs 12, track 43*

Shout! Shout! Shout with joy!  
Shout with joy to God all the earth!  
Sing! Sing! Sing the glory!  
Sing the glory of His name!  
Say! Say! Say to God!  
Say to God, "How awesome are your deeds."  
Come, Come, Come and see,  
Come and see what God has done!  
Let me tell you what He has done for me!  
Psalm Sixty-six,  
one through three, five, nine, sixteen.

"Now it's time to do a bit more deep down investigating. Let's see what Detective Dan wants us to help him figure out. Would someone like to get it out for me?"

take out



Place in



Visual Aid



# Detective Dan's Listening Assignment #1

# Detective Dan's Listening Assignment #1



Hi, Deep Down Detectives!  
I'm working on a brand-new case called:  
"The Case of the Boastful Man."

I need to find out:

1. Who needed bread? Why was it so hard to get it?  
AND
2. Who never forgot to give them bread? What was special about it?

Can you help me? Listen carefully to the story and you might just hear the answers!

Thanks!  
Detective Dan

**Then say,** "Ok, Deep Down Detectives! Put on your best listening ears and see if you can hear the answers to Detective Dan's questions. When I finish telling the story, we will see if we can answer all of his questions."

*Read the Bible Truth story, putting up the storyboard pictures as you tell it. At the end of the story, repeat the questions and lead the children in answering them. Present the gospel and close in prayer.*

\*Answers to assignment questions, the gospel and ACTS prayer are also included at the end of the story text.\*

Answers:

1. **Who needed bread? Why was it so hard to get it?**  
The people of Israel needed bread in the wilderness. It was so hard to get because the wilderness was dry and there were only weeds and rocks! No food!
2. **Who never forgot to give them bread? What was special about it?**  
The LORD never forgot to give them bread. He gave them "manna"--special bread from heaven that they collected from the ground every morning.

**For You and Me:**

The LORD was faithful to take care of the people of Israel. He fed them bread and meat, even when it seemed impossible. The LORD has been faithful to us in an even more amazing way! He promised to send a Savior to save us from our sins and He kept His promise! He sent His Son, Jesus to live a perfect life and offer it up as the full payment for sins when He suffered and died on the cross. Then on the third day, Jesus rose up from the dead showing He had really done it. He had really beaten sin and death for us! And now, all who turn away from their sins and trust in Jesus as their Savior, they will be forgiven their sins and become God's dearly loved people!

God gives them a brand new heart to know and love God. And one day, when they die, they will go to live with God and enjoy Him, as happy as anyone can ever be, forever! Jesus can be our Savior, too. Ask Him! He loves to help us! How faithful the LORD is to us!

take out



Place in



Visual Aid



# Detective Dan's Listening Assignment #2

# Detective Dan's

## Listening Assignment #2



Hi, Deep Down Detectives!

I'm still working on the case called:

"The Case of the Boastful Man."

Our Bible Verse is Psalm 66:1-3,5,16, NIV 1984:

"Shout with joy to God, all the earth! Sing the glory of His name! Say to God, "How awesome are your deeds! Come and see what God has done... Let me tell you what he has done for me."

I need to find out:

1. Who was the man who was boastful? Who did he first boast about?

AND

2. Why did he change his boast? Who did boast in, instead?

Can you help me? Listen carefully to the story and you might just hear the answers! Thanks for your help!

Detective Dan

**Then say,** "Ok, Deep Down Detectives! Put on your best listening ears and see if you can hear the answers to Detective Dan's questions. When I finish telling the story, we will see if we can answer all of his questions."

*Read the Bible Truth story, putting up the storyboard pictures as you tell it. At the end of the story, repeat the questions and lead the children in answering them. Present the gospel and close in prayer.*

\*Answers to assignment questions, the gospel and ACTS prayer are also included at the end of the story text.\*

Answers:

**Our Bible Verse is Psalm 66:1-3,5,16, NIV 1984:**

"Shout with joy to God, all the earth! Sing the glory of His name! Say to God, "How awesome are your deeds! Come and see what God has done... Let me tell you what he has done for me."

**1. Who was the man who was boastful? Who did he first boast about?** Paul. He boasted in himself and all the good things he did.

**2. Why did he change his boast? Who did boast in, instead?** He changed his boast when God showed him that he was a sinner who did not deserve to be one of God's people. He changed his boast to God and how He had forgiven his sins through Jesus.

**For You and Me:**

God has been kind to give each of us many good gifts. He has made us able to do many good things. Sometimes, we might want to boast about the good things we can do. But like Paul, God wants us to boast only in Him. He is the giver of all those good gifts; and, He is the only one who can forgive our sins through Jesus. We need Him to do that most of all! That's why Paul made much of God. And, that's what God wants us to do, too. He wants us to turn away from our sins and trust in Jesus as our Savior. He wants us to praise Him for being our God and for being so good to us. Ask Him to help you do this. He loves to answer this prayer!!

take out



Place in



Visual Aid

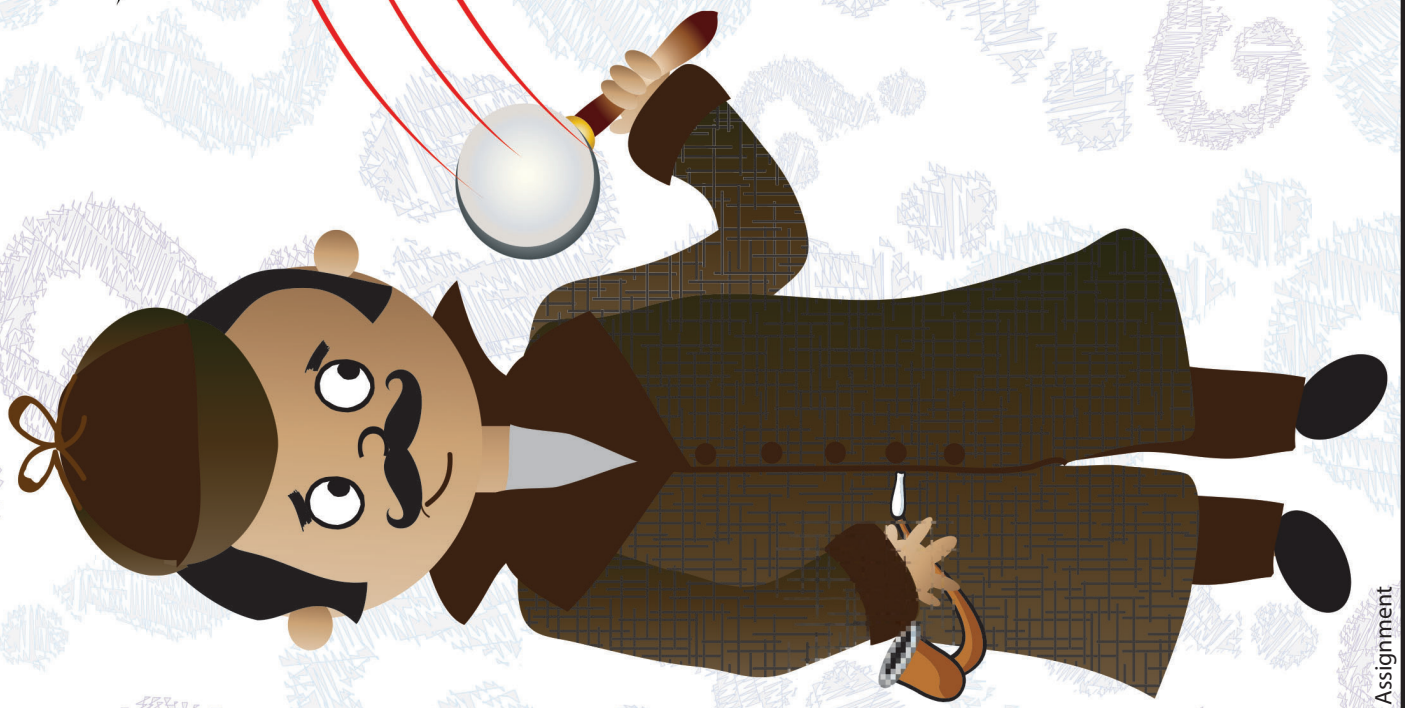

# Detective Dan's Listening Assignment #3

# Detective Dan's

## Listening Assignment #3



Hi, Deep Down Detectives!

I'm still working on the case called:

"The Case of the Boastful Man."

I found SIX clues, but TWO of them are NOT in the story.

They are: a star, God's law, a shoe, a Pharisee, the cross, wild animal.

*Hold up each of the six pictures for the children to see as you identify them. Better yet, put them up on your flannelgraph board, off to one side.*

I need to know:

1. Which FOUR pictures belong in the story and which TWO do NOT?
2. Who did Paul boast in most of all? Why did he boast in Him so much?

Can you help me? Listen carefully to the story and you might just hear the answers!

Thanks!

Detective Dan

**Then say,** "Ok, Deep Down Detectives! Put on your best listening ears and see if you can hear the answers to Detective Dan's questions. When I finish telling the story, we will see if we can answer all of his questions!"

*Read the Bible Truth story, putting up the storyboard pictures as you tell it. At the end of the story, repeat the questions and lead the children in answering them. Present the gospel and close in prayer.*

\*Answers to assignment questions, the gospel and ACTS prayer are also included at the end of the story text.\*

Answers:

**Our six clues were: a pie, a rock, a hippo, a weed, a man named Moses, and manna.**

**1. Which four belong in our story?**

God's law, the Pharisee, the cross and the wild animal belong. The star and the shoe do not.

**2. Who did Paul boast in most of all? Why did he boast in Him so much?**

He boasted in God. Because God had forgiven his sins and saved him through Jesus, when he never, ever deserved it.

**For You and Me:**

What a great work God did in Paul's heart! He had been a man who boasted in how well he could keep God's laws. God changed him into a man who knew that only through Jesus that he could ever please God and become one of His people. Paul was so grateful to God for saving him! God can save us, too, when we turn away from our sins and trust in Jesus as our Savior. Then, what a lot we will have to be grateful to God for, too!



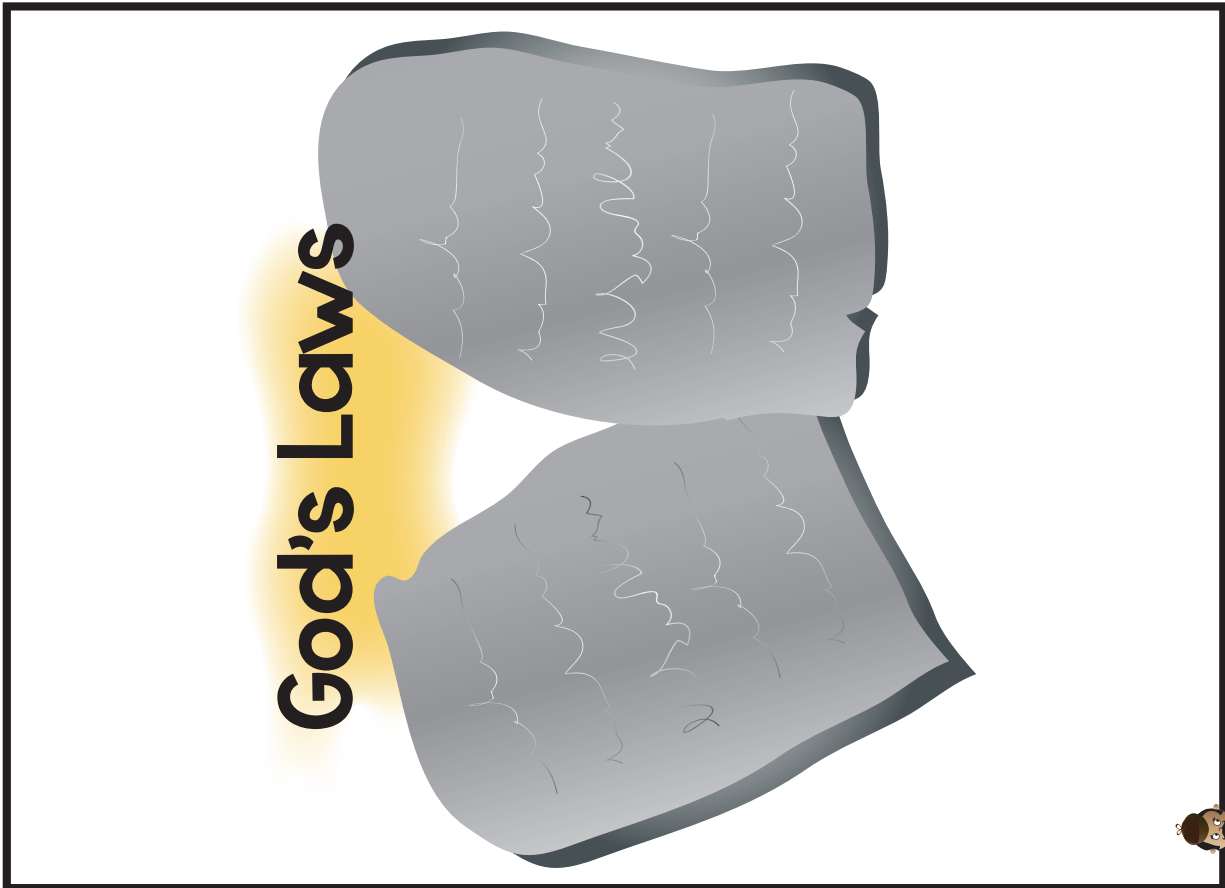

**God's Laws**



**God's Law**

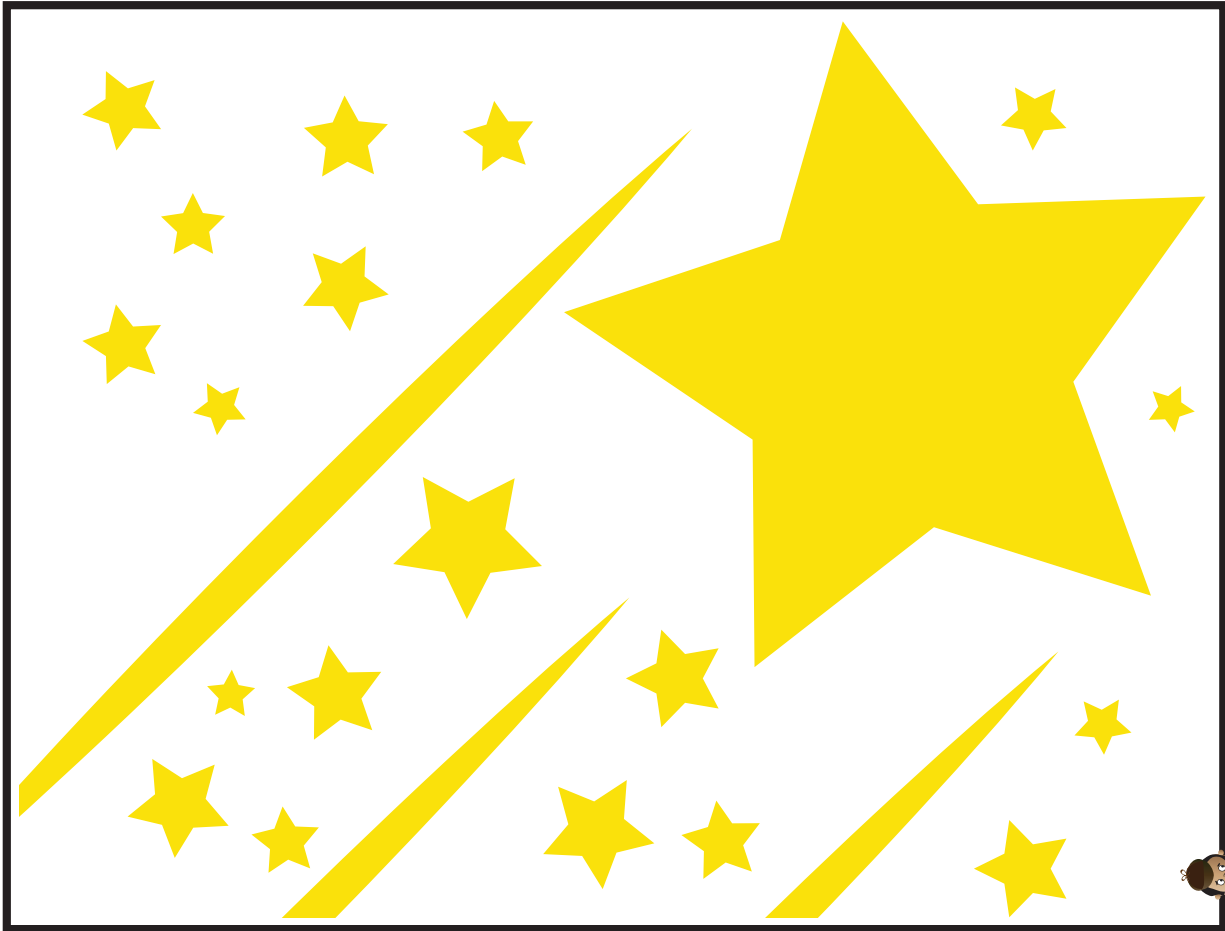

**A Star**



VISUAL  
AID  
#5C

Place in  
DDD  
Bible™

take out  
Big  
Question  
Briefcase  
of BQB

DDD 12.8 Lesson 3 Listening Assignment Clue Picture 2 for kids

VISUAL  
AID  
#5C

Place in  
DDD  
Bible™

take out  
Big  
Question  
Briefcase  
of BQB

DDD 12.8 Lesson 3 Listening Assignment Clue Picture 1 for kids

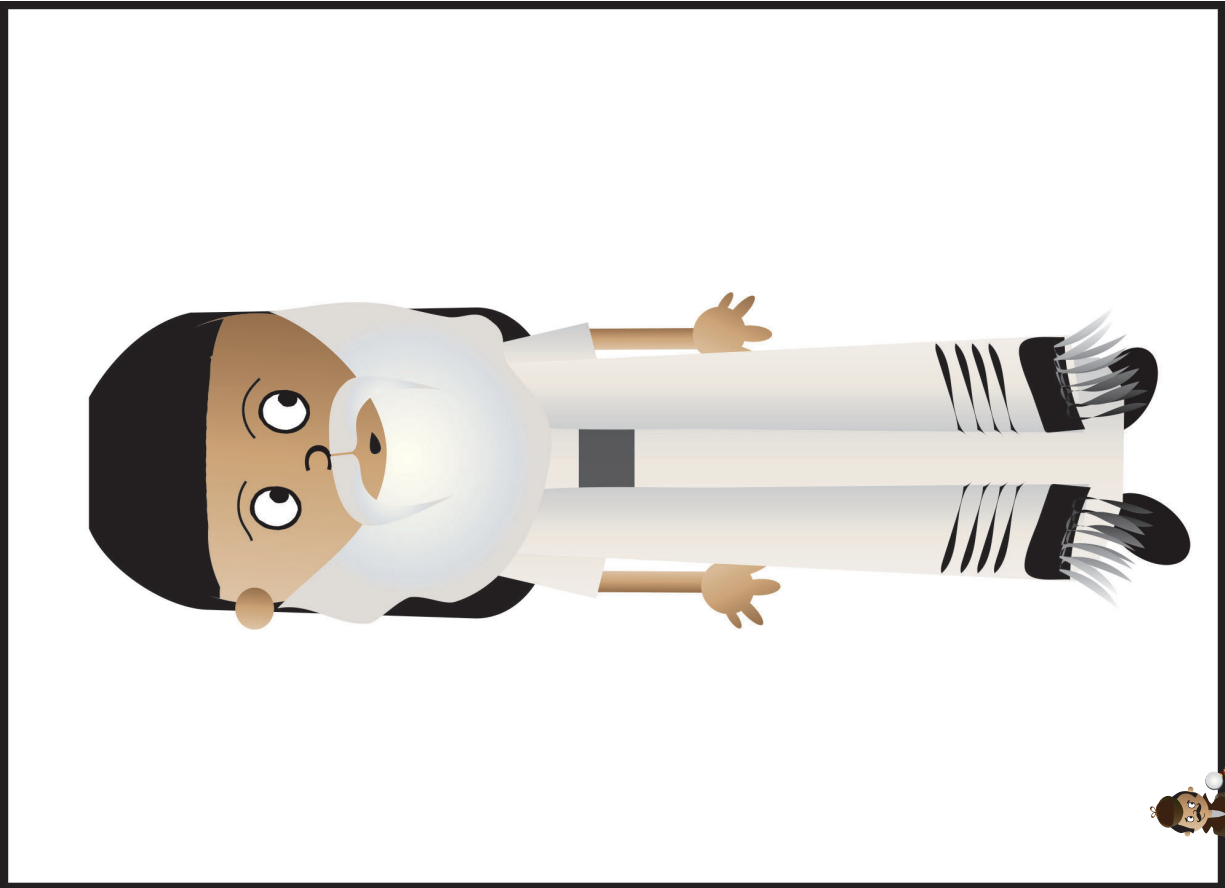

A Pharisee

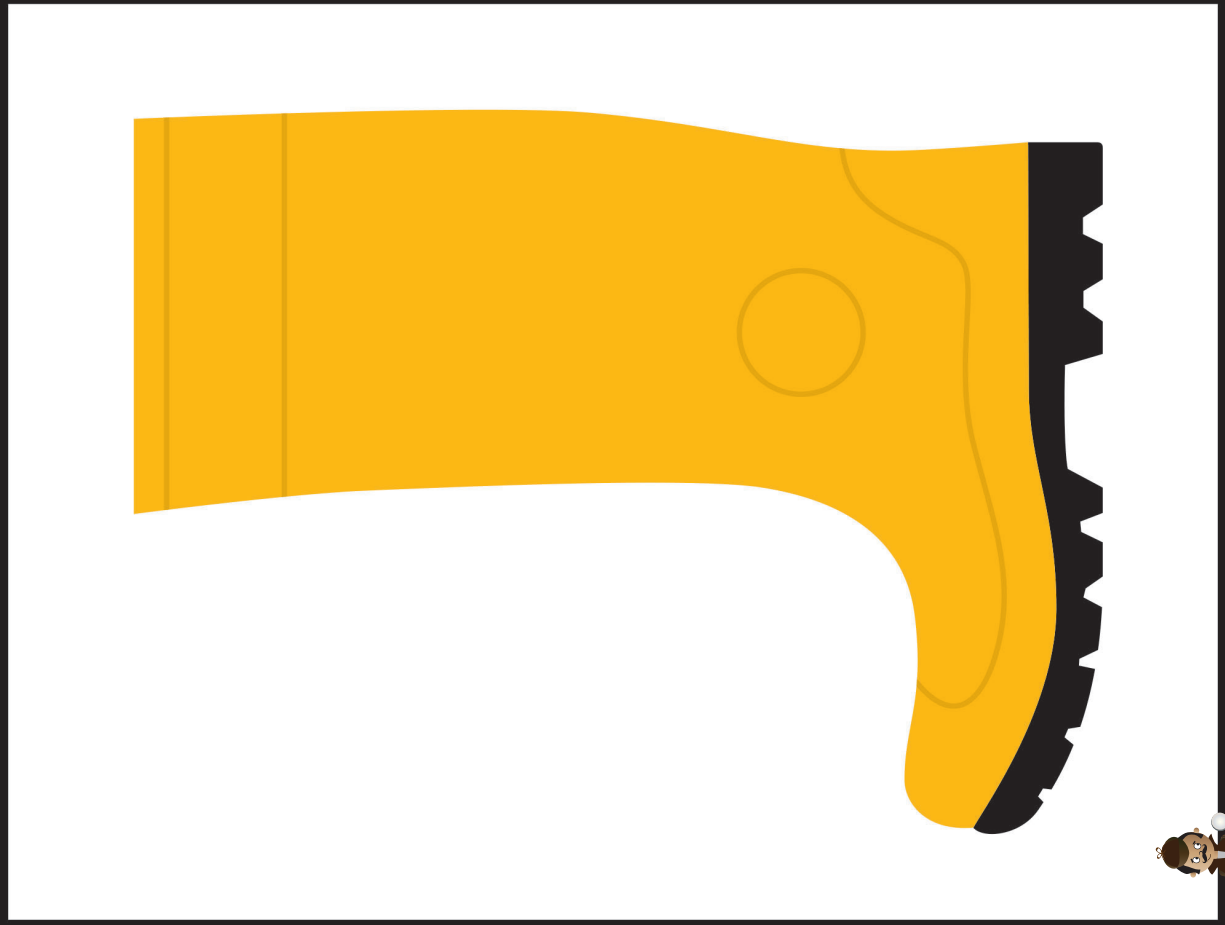

A Shoe

VISUAL  
AID  
#5C

Place in  
DDD  
Bible™

take out  
Big  
Question  
Briefcase  
of BQB

VISUAL  
AID  
#5C

Place in  
DDD  
Bible™

take out  
Big  
Question  
Briefcase  
of BQB

DDD 12.8 Lesson 3 Listening Assignment Clue Picture 4 for kids

DDD 12.8 Lesson 3 Listening Assignment Clue Picture 3 for kids

# Wild Animal



# The Cross

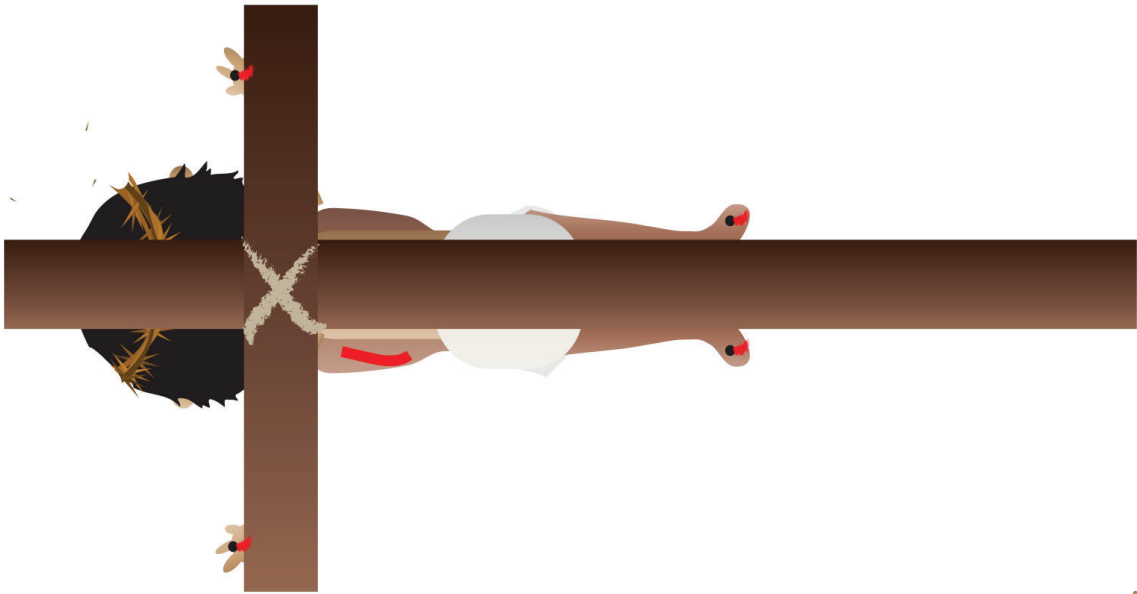

VISUAL  
AID  
#5C

Place in  
DDD  
Bible™

take out  
Big  
Question  
Briefcase  
of BQB

VISUAL  
AID  
#5C

Place in  
DDD  
Bible™

take out  
Big  
Question  
Briefcase  
of BQB

DDD 12.8 Lesson 3 Listening Assignment Clue Picture 6 for kids

DDD 12.8 Lesson 3 Listening Assignment Clue Picture 5 for

# “The Case of the Boastful Man” Acts 7-9,22; Romans; 1 & 2 Corinthians; Ephesians; Philippians

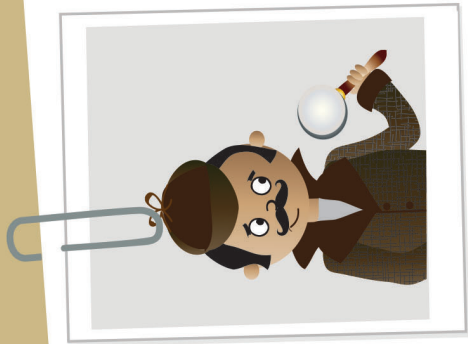

## Detective Dan's Listening Assignment #1

1. Who was the man who was boastful? Who did he first boast about?
2. Why did he change his boast? Who did boast in, instead?



## Detective Dan's Listening Assignment #2

### **Psalm 66:1-3,5,16, NIV**

“Shout with joy to God, all the earth! Sing the glory of His name! Say to God, “How awesome are your deeds! Come and see what God has done... Let me tell you what he has done for me.”

1. Who changed from being a man who boasted about himself to a man who boasted about God?
2. What awesome deed of God did he especially love to boast about?

(more listening and discussion questions are included in the curriculum at [praisefactory.org](http://praisefactory.org))

**I. Paul was a man who was always boasting.**

**What is boasting? It's telling how great someone is to others. Now, some people boast in themselves, and some people boast in others.**

**Many times, boasting is bad, especially when we boast about ourselves. But some boasting is good when we boast about the right person. Paul started out as a bad boaster, but he became a good boaster. Can you guess who Paul learned to boast in?**





1. Paul was a man who was always boasting. What is boasting? It's telling how great someone is to others. Now, some people boast in themselves, and some people boast in others. Many times, boasting is bad, especially when we boast about ourselves. But some boasting is good when we boast about the right person. Paul started out as a bad boaster, but he became a good boaster. Can you guess who Paul learned to boast in?

**2. It was the LORD! Yes, Paul loved to make much of the one, true God!**



2. It was the LORD! Yes, Paul loved to make much of the one, true God!

**3. “Some might think I have a lot to boast about in MYSELF,” Paul told people. “I certainly used to think I did,” he admitted.**

**“After all, I was born in an important city as a Roman. I enjoyed lots of nice things and was treated as someone special. That sounds like a lot to boast about, doesn’t it?” Paul explained.**



3. "Some might think I have a lot to boast about in MYSELF," Paul told people. "I certainly used to think I did," he admitted. "After all, I was born in an important city as a Roman. I enjoyed lots of nice things and was treated as someone special. That sounds like a lot to boast about, doesn't it?" Paul explained.

**4. “My parents were good Jews. I grew up learning God’s Word and obeying it. That sounds like a lot to boast about, too, doesn’t it?” Paul told people.**



4. "My parents were good Jews. I grew up learning God's Word and obeying it. That sounds like a lot to boast about, too, doesn't it?" Paul told people.

**5. “I was really, really smart. I went to the school for smart boys in the big city of Jerusalem. I had great teachers like Gamaliel to teach me. That sounds like something else I could boast about,” Paul said.**





5. "I was really, really smart. I went to the school for smart boys in the big city of Jerusalem. I had great teachers like Gamaliel to teach me. That sounds like something else I could boast about," Paul said.

**6. “I stayed in school a long time. I was one of the best students. I became a Pharisee. I became very good at knowing God’s laws and keeping all of the teachers’ extra, little rules. I was better than others at keeping them. I thought I pleased God by being a good law-keeper,” Paul told them.**

**“Oh, I thought I had so much to boast in!” he exclaimed.**

**Good, Good, Good**

**Proud, Proud, Proud**

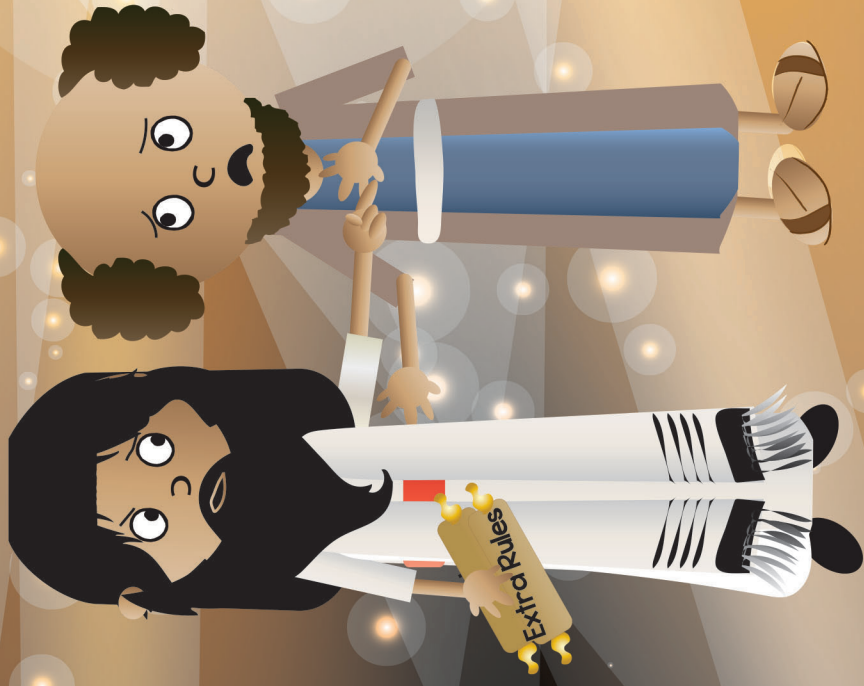

6. "I stayed in school a long time. I was one of the best students. I became a Pharisee. I became very good at knowing God's laws and keeping all of the teachers' extra, little rules. I was better than others at keeping them. I thought I pleased God by being a good law-keeper," Paul told them. "Oh, I thought I had so much to boast in!" he exclaimed.

**7. “But I was wrong,” Paul sadly said. “I had nothing to boast about. I was just like everyone else. My heart was full of sin. I was a lawbreaker, not a law-keeper. I could never really please God by obeying laws and rules,” Paul confessed.**

# God's Laws

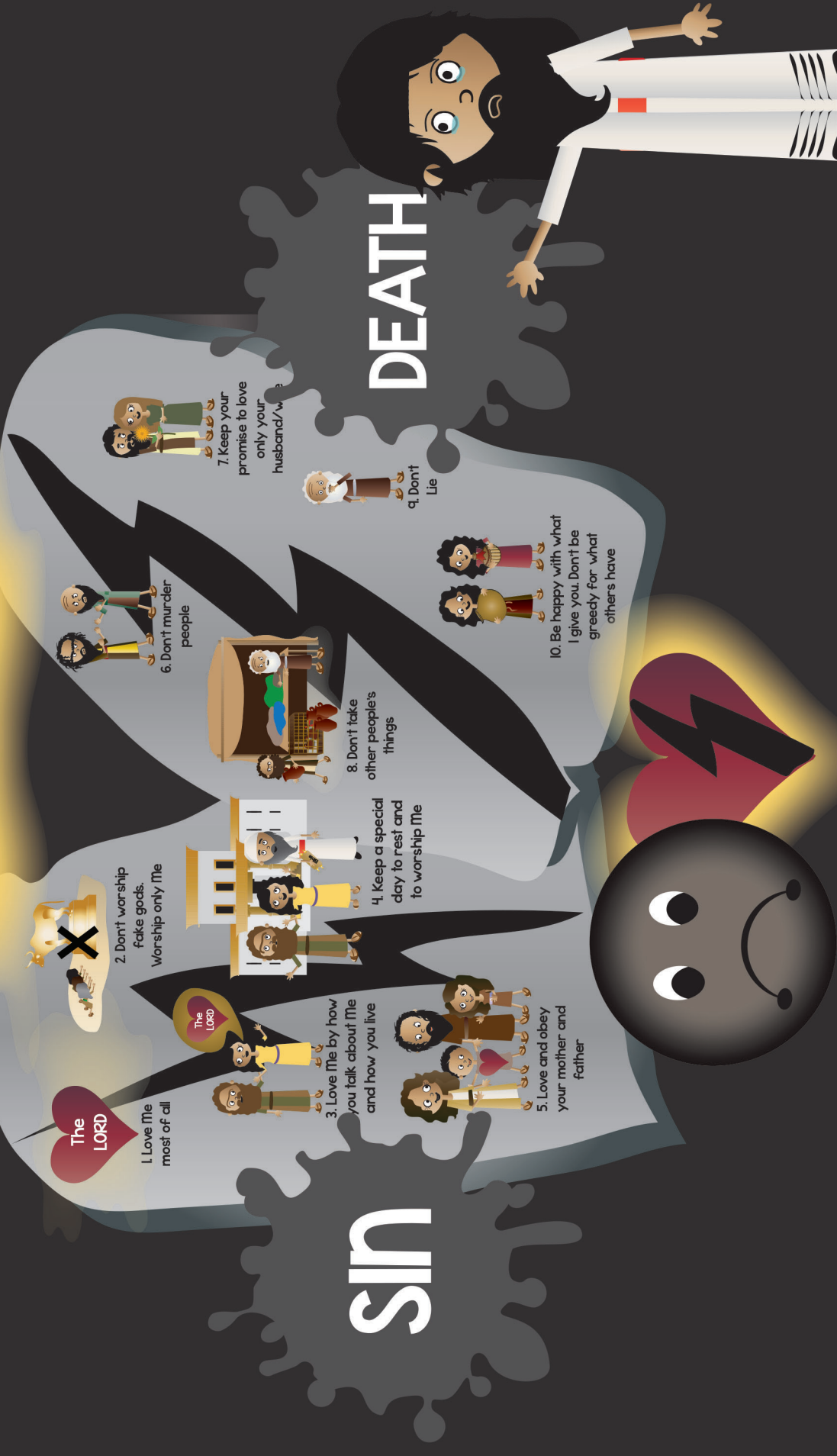

7. "But I was wrong," Paul sadly said. "I had nothing to boast about. I was just like everyone else. My heart was full of sin. I was a lawbreaker, not a law-keeper. I could never really please God by obeying laws and rules," Paul confessed.

**8. “I did some terrible things. I hated Jesus and told everyone that He was a fake Savior. I hunted down His followers. I had them hurt and put in jail. I was even happy if they died! I thought these things pleased God. But I was wrong. So terribly wrong!” Paul exclaimed.**

**“No, I had nothing to boast about at all. I deserved God’s punishment for my sins. I could never please Him on my own,” Paul admitted.**



8. "I did some terrible things. I hated Jesus and told everyone that He was a fake Savior. I hunted down His followers. I had them hurt and put in jail. I was even happy if they died! I thought these things pleased God. But I was wrong. So terribly wrong!" Paul exclaimed. "No, I had nothing to boast about at all. I deserved God's punishment for my sins. I could never please Him on my own," Paul admitted.

**q. “But do you know what? God saved me from my sins, and He made me one of His people!” Paul said.**

**“Yes, God saved me through His Son, Jesus! He forgave me—yes, even me, the worst of sinners! What a wonderful Savior He is!” Paul said. “And that’s why I love to boast about God. That’s why I want to do anything for Him. I want to make much of God because of what He’s done for sinners like me!”**



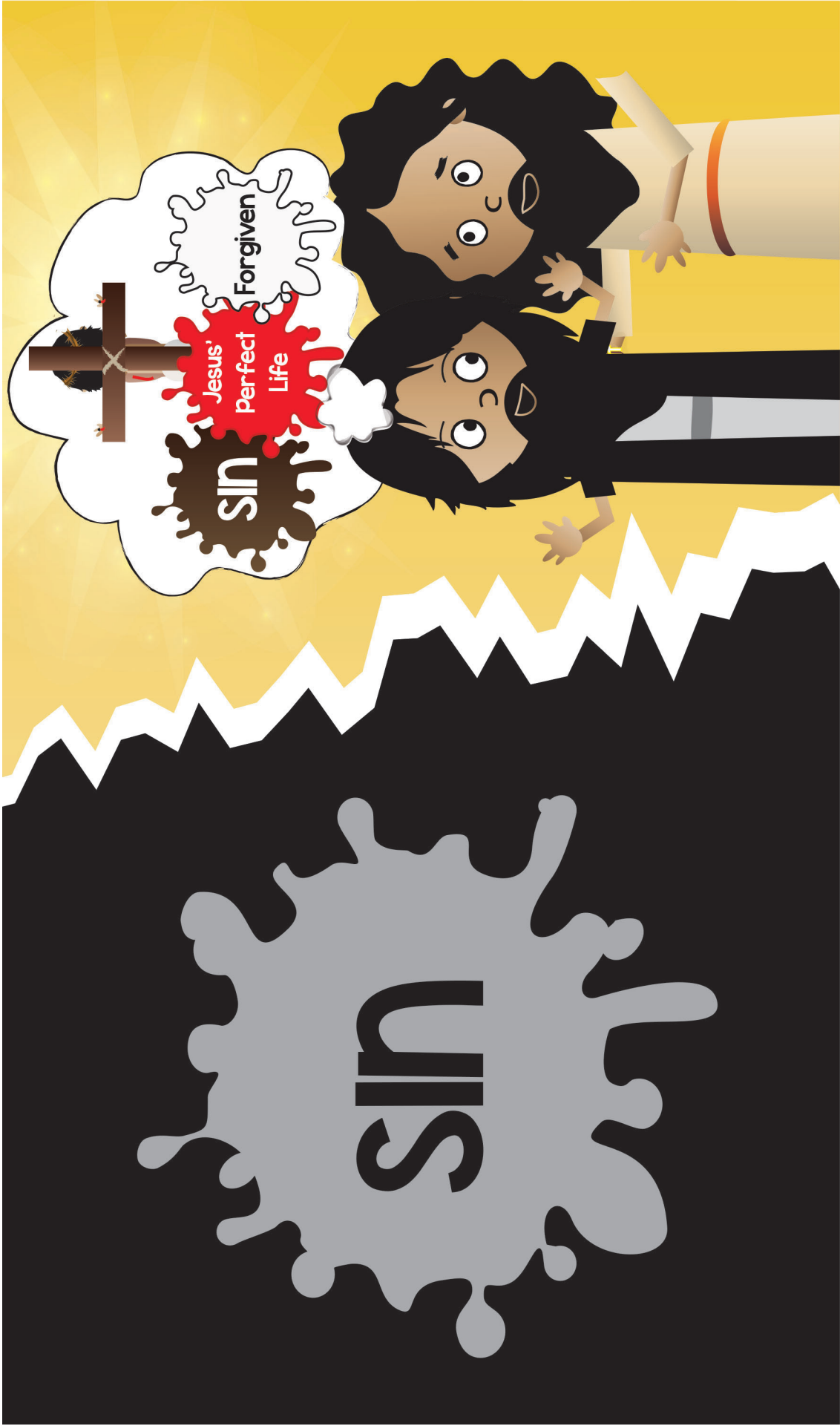

Q. "But do you know what? God saved me from my sins, and He made me one of His people!" Paul said. "Yes, God saved me through His Son, Jesus! He forgave me—yes, even me, the worst of sinners! What a wonderful Savior He is!" Paul said. "And that's why I love to boast about God. That's why I want to do anything for Him. I want to make much of God because of what He's done for sinners like me!"

**10. So, for the rest of his life, in everything he did, and everything he said, to EVERYONE he met, Paul boasted about the LORD. There was never a time when Paul could not think of a way to make much of God!**



**He's the greatest!**

10. So, for the rest of his life, in everything he did, and everything he said, to EVERYONE he met, Paul boasted about the LORD. There was never a time when Paul could not think of a way to make much of God!

**II. Sometimes, Paul traveled to big cities and talked to smart people who thought believing in Jesus was silly.**

**Paul boasted in God to them: “You may think believing in Jesus is silly, but God’s silliness is smarter than all your smartness! Jesus really IS God’s Son! Turn away from your sins. Trust in Him as your Savior and be saved!” he urged them.**



II. Sometimes, Paul traveled to big cities and talked to smart people who thought believing in Jesus was silly. Paul boasted in God to them: "You may think believing in Jesus is silly, but God's silliness is smarter than all your smartness! Jesus really IS God's Son! Turn away from your sins. Trust in Him as your Savior and be saved!" he urged them.

**12. WHO was Paul making much of when he talked to these smart people? He was making much of the LORD! He loved to tell everyone how great is the one, true God!**



12. WHO was Paul making much of when he talked to these smart people? He was making much of the LORD! He loved to tell everyone how great is the one, true God!

**13. Sometimes, Paul talked to people who hurt him and threw him in jail when he told them about Jesus.**

**But Paul boasted in God to them: “I don’t like to be hurt or be put in jail, but Jesus suffered far more than this for me. He suffered and died for my sins on the cross. He can forgive your sins, too, if you turn away from disobeying God and trust in Jesus as your Savior,” Paul told them. “I am happy to suffer for Him who suffered so much for me, especially if it helps you to believe in Him, too!” he said.**





13. Sometimes, Paul talked to people who hurt him and threw him in jail when he told them about Jesus. But Paul boasted in God to them: "I don't like to be hurt or be put in jail, but Jesus suffered far more than this for me. He suffered and died for my sins on the cross. He can forgive your sins, too, if you turn away from disobeying God and trust in Jesus as your Savior;" Paul told them. "I am happy to suffer for Him who suffered so much for me, especially if it helps you to believe in Him, too!" he said.

**14. Paul was making most of WHO when he thought about his suffering? He was making much of the LORD! He loved to tell everyone how great is the one, true God!**



**He's the greatest!**

14. Paul was making most of WHO when he thought about his suffering? He was making much of the LORD! He loved to tell everyone how great is the one, true God!

**15. Sometimes, Paul preached to God's people who gathered at a worship house to hear God's Word.**

**Paul read the Bible to them and showed them all God's promises about Jesus. "How great God is! He planned all along to send Jesus to save His people. God put it here in the Bible for us to read and to help us believe," Paul told them.**

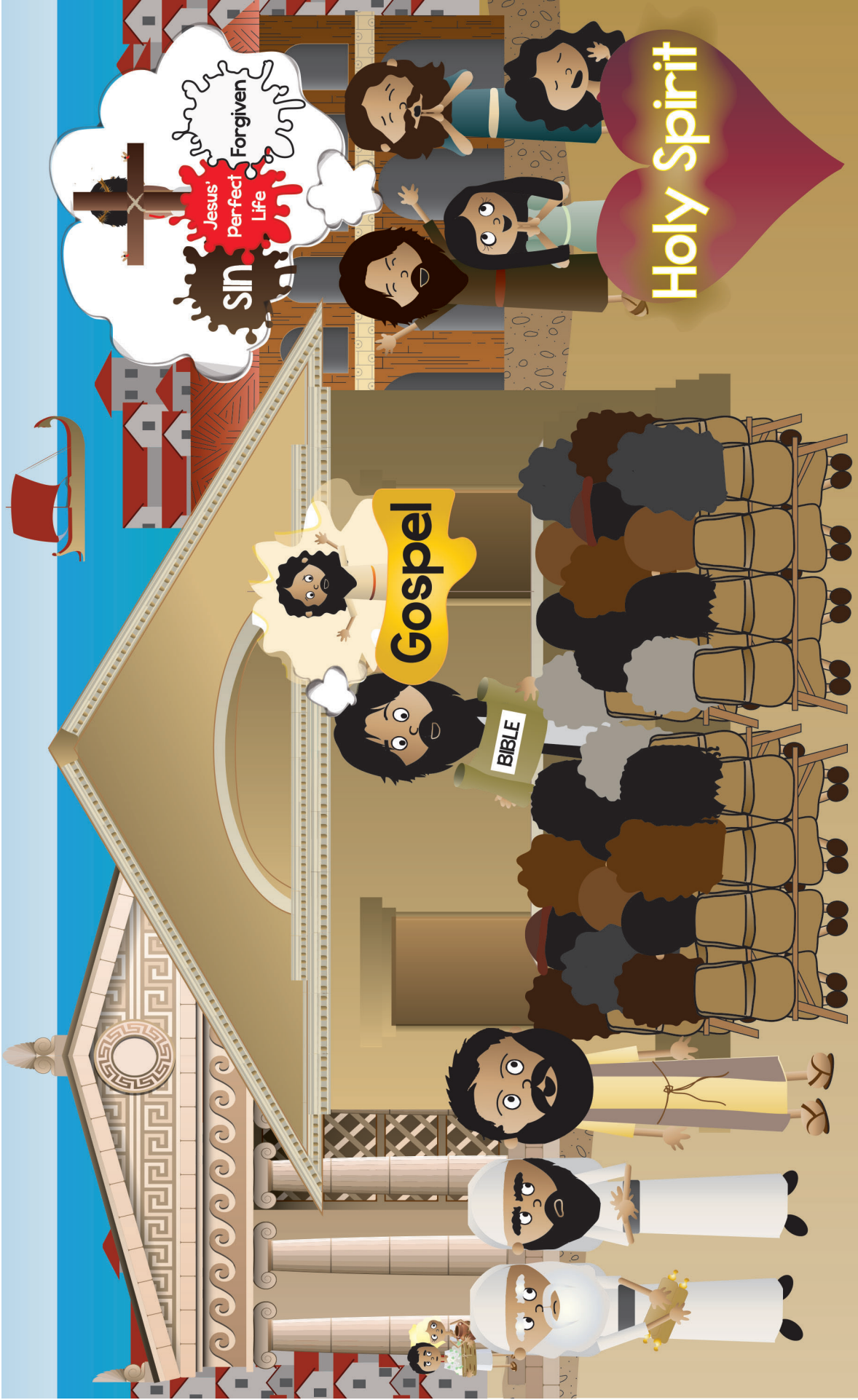

15. Sometimes, Paul preached to God's people who gathered at a worship house to hear God's Word. Paul read the Bible to them and showed them all God's promises about Jesus. "How great God is! He planned all along to send Jesus to save His people. God put it here in the Bible for us to read and to help us believe," Paul told them.

**16. WHO was Paul making much of when he preached God's Word?  
He was making much of the LORD! He loved to tell everyone how  
great is the one, true God!**



16. WHO was Paul making much of when he preached God's Word? He was making much of the LORD! He loved to tell everyone how great is the one, true God!

**17. Sometimes, Paul was weak and sick. His eyes hurt and he could hardly write. "God always makes me strong to do whatever He wants me to do. When I am weak, He can show everyone how strong He is!" Paul boasted.**





17. Sometimes, Paul was weak and sick. His eyes hurt and he could hardly write. "God always makes me strong to do whatever He wants me to do. When I am weak, He can show everyone how strong He is!" Paul boasted.

**18. WHO was Paul making much of when he talked about his weakness?  
He was making much of the LORD! He loved to tell everyone how  
great is the one, true God!**



18. WHO was Paul making much of when he talked about his weakness? He was making much of the LORD! He loved to tell everyone how great is the one, true God!

**19. Paul faced death many times. Once, at the teeth of wild animals; and another time, out on a sinking boat on stormy seas. Paul boasted in God then, too.**

**“God can even rescue me from the teeth of wild animals. He can even save me out in the stormy seas. There is nothing He can’t do,” Paul said. And sure enough, God DID save him!**



19. Paul faced death many times. Once, at the teeth of wild animals; and another time, out on a sinking boat on stormy seas. Paul boasted in God then, too. "God can even rescue me from the teeth of wild animals. He can even save me out in the stormy seas. There is nothing He can't do," Paul said. And sure enough, God DID save him!

**20. WHO was Paul making much of, even in these very scary times?  
He was making much of the LORD! He loved to tell everyone how  
great is the one, true God!**



**He's the greatest!**

20. WHO was Paul making much of, even in these very scary times? He was making much of the LORD! He loved to tell everyone how great is the one, true God!

**21. “And when I DO die,” Paul told people, “God will take me to live with Him forever in heaven. Through Jesus, God has already beat sin and death for me! Going to live with Him will be best of all!” Paul exclaimed.**





21. "And when I DO die," Paul told people, "God will take me to live with Him forever in heaven. Through Jesus, God has already beat sin and death for me! Going to live with Him will be best of all!" Paul exclaimed.

**22. WHO was Paul making much of, even when he talked about dying? He was making much of God! Yes, no matter what Paul went through, no matter who he talked to, Paul boasted in the LORD. He loved to make much of Him!**



**He's the greatest!**

22. WHO was Paul making much of, even when he talked about dying? He was making much of God! Yes, no matter what Paul went through, no matter who he talked to, Paul boasted in the LORD. He loved to make much of Him!

## 12.8 Simple Story Scenes

# "The Case of the Boastful Man" Acts 7-9, 22; Romans; 1 & 2 Corinthians; Ephesians; Philippians

# SOLVED



## Detective Dan's Listening Assignment #1

1. Who was the man who was boastful? Who did he first boast about?  
Paul. He boasted in himself and all the good things he did.
2. Why did he change his boast? Who did boast in, instead?  
He changed his boast when God showed him that he was a sinner who didn't deserve to be one of God's people. He changed his boast to God and how He had forgiven his sins through Jesus.

**For You and Me:**  
God has been kind to give each of us many good gifts. He has made us able to do many good things. Sometimes, we might want to boast about the good things we can do. But like Paul, God wants us to boast only in Him. He is the giver of all those good gifts; and, He is the only one who can forgive our sins through Jesus. We need Him to do that most of all! That's why Paul made much of God. And, that's what God wants us to do, too. He wants us to turn away from our sins and trust in Jesus as our Savior. He wants us to praise Him for being our God and for being so good to us. Ask Him to help you do this. He loves to answer this prayer!

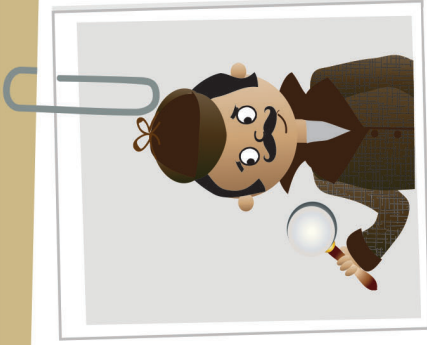

## Detective Dan's Listening Assignment #2

Psalms 66:1-3, 5, 16, NIV

"Shout with joy to God, all the earth! Sing the glory of His name! Say to God, "How awesome are your deeds! Come and see what God has done... Let me tell you what he has done for me."

1. Who changed from being a man who boasted about himself to a man who boasted about God?  
Paul did.
2. What awesome deed of God did he especially love to boast about?  
For forgiving his sins through Jesus.

What about you and me?

God gives the whole earth reason to shout for joy. He gives the whole earth reason to glory in his name. Everywhere are God's awesome deeds in the earth. More than anyone else, God's people love to make much of God and all of the good things He has done. After all, He has saved from their sins and made them His dearly-loved people forever. We can become God's people, too, when we turn away from our sins and trust in Jesus as our Savior. Then like the rest of God's people, we will have so very much to boast in God about!

## 12.8 Simple Story Scenes

How Should God's People Live?  
They Should Live Like Jesus...  
By Making Much of God!

# The Gospel



God's people make much of God because of all He's done for them. He's treated them so much better than they could ever deserve.

God's people, like all people, had chosen to disobey God. They deserved His punishment. But God sent His Son, Jesus, to live a perfect life and offer it up as He died on the cross as the full payment for their sins. On the third day, Jesus rose from the dead. He had beaten sin and death for them.

Now, all who turn away from their sins and trust in Jesus as their Savior can be God's people. They can know God in their hearts. And one day, they will go to live with God forever.

This is how we can become God's people, too. And if we do, we will want to make a big deal about God's wonderful love for us!

Ask Him to help  
you!



## 12.8 Simple Story Scenes



# A Prayer

A God, we praise You. You are perfectly good, loving, and wise. You deserve all our praise.

C God, please forgive us for choosing to not praise You or delight in You, as You deserve. Many times, we choose to make much of ourselves or others, instead. We need a Savior!

T Thank You, God, for sending Jesus to save us from our sins. He alone is Savior. He deserves for us to make much of Him.

S God, please work in our hearts. Help us turn away from our sins and trust in Jesus as our Savior. Help us to make much of You. Help us to delight in You and how wonderful You are.

In Jesus' name we pray. Amen.



## 12.8 Simple Story Scenes

# DEEP DOWN DETECTIVES



**Other Visual Aids**

## Big Question Box/Briefcase

### What You Want

The Big Question Briefcase is a briefcase or other container with these characteristics:

- Ideally, this should be around 17" x 12", but needs to be at least big enough to fit a 8 ½" x 11" sheets of paper inside it.
- Have various pockets to put these sheets in
- Is attractive or curious looking to preschoolers
- Not necessary, but extremely fun, if it has a combination lock

### Finding a Briefcase:

You can certainly buy one new, but you always may find a used one at a thrift shop. Or, someone may have one they want to donate. We use one that stores valuables in it and is the 17" x 12" size. Very durable and has the lock feature that the kids love.

You also can move away from the briefcase idea and use a little trunk or other box for your substitute briefcase. Just change the name to the Big Question Box, if you use a box instead. A boot box or the cardboard box that 10 reams of copy paper comes in is a great size, if you are using a box.

If you use a box, but want a lock-like feature, that's easy to do. Simply cut "straps" out of felt or vinyl and glue in place to the top and bottom sides of the box on one side, with the top strap overlapping the bottom straps. Add velcro to the top and bottom pieces so that they meet and fasten. Make back "hinges" for the box with the felt/vinyl straps, too. Or, you can simply add a belt around the box that has to be unfastened before the box can be opened.

Here are some suggestions for decorating a box or even the outside of your briefcase to make it appealing.

### Supplies

Your box/briefcase  
Plain white contact paper or white cardstock  
Colorful wrapping paper  
Glitter glue  
Markers  
Sequins, fake jewels, buttons, rick rack, etc.  
Other decorating supplies  
Stickers  
Glue  
Clear packing tape

### Directions

1. If you are using a box that has wording on it, you will first need to make plain surfaces for decorating and a hinge for the lid. Stick the white contact paper or white cardstock to each side of the box. On the other hand, you can also use colorful wrapping paper. Then, make a lid by sticking the clear packing tape along one long side of the box, attaching the lid to the box.

2. Use the craft decorating supplies to decorate the box. If desired, you can put a big question mark on top of the box, but remember that you are working with two and three year olds: the question mark symbol is not very meaningful to them yet.

## Making a Flannelgraph Storyboard

for use in story-telling and in playing the story review games

While you may decide to use sticky tac and stick your storyboard pictures to a white board, it is very easy to make a flannelgraph board. The advantage to the flannelgraph board is that the pictures stick very easily and there is no messing with the sticky-tac.

### Supplies

Large Format Pictures Board: AT LEAST a 36" x 48" foamboard or corkboard (We actually use a far bigger canvas and attach it to the wall) A science project board with the two sides that fold out makes a good 36" x 48" board.

Small Format Pictures Board: AT LEAST a 24" x 36" (to 36" x 48)" board

Large piece of neutral-colored felt to cover your board with extra to overlap over to the back, if desired.

Glue gun and glue sticks

### Directions

1. Center felt on front side of board. Turn over. Secure in place with glue.

## Making Durable Storyboard Pictures

for use in story-telling and in playing the story review games

Whether you purchase the Deep Down Detectives storyboard pictures from Amazon or print them off the website (included in the Deep Down Detectives Visual Aids book), you will want to find some way to make them more durable. They are used not only as a part of telling the story, but are integral in the story review games. Here's how we make ours durable enough to be used over and over again. **See note below for other simpler options for using these pictures.**

### Supplies

Deep Down Detectives Visual Aids book (purchased or downloaded)

White cardstock or printer paper (if downloading pictures)

Sticky-back velcro, circles or cut pieces; or sticky tac putty

Laminator or Self-laminating sheets

Sturdy Sheet Protectors, preferably the "Secure Top" kind, like offered by Avery

Flannelgraph pictures for the Bible stories found at [www.praisefactory.org](http://www.praisefactory.org) with each unit's resources.

### Directions

1. Purchase from Amazon or download and print out the storyboard figures.
2. Cut out flannelgraph figures.
3. Laminate the figures.

**Special tip:** When laminating the big background pictures that are two (and sometimes even three or four) pieces put together, leave a small gap between the two pieces before laminating together. This small space acts like a hinge and allows you to fold up pictures without hurting them into a manilla envelope that fits 8.5" x 11" sheets of paper along with all of the smaller, regular-sized storyboard pictures.

4. If using a flannelgraph board: Stick a piece of sticky backed velcro (ROUGH SIDE) onto the back of each figure. If using sticky tack and whiteboard: simply stick a small amount of sticky tack on the back of a picture when using it. Remove and store sticky tack in airtight container.

**Note:** Instead of using all of the pictures as separate flannelgraph pieces, you can choose to use only a few (helpful to have 10 for the story review game); you can clump them onto posterboard and make them into picture scenes; or, you can simply use the Storyboard Picture Guide as a single picture. At [praisefactory.org](http://praisefactory.org), go to DDD Bits and Pieces for a 22" x 28" poster size jpg of this picture guide if you want to create a large version.

## The Deep Down Detectives “Bible” Folder

This is a homemade folder that looks (kinda) like the cover of a Bible. You will use this to put the Bible verse, the Bible Story and storyboard pictures to help make the point that the truths you are teaching them come from the Bible.

### Supplies

1 piece of 22" x 28" posterboard (white is fine. Green or brown is nice)

Glue

Stapler and staples or packing tape

The Bible Cover pictures (see online with resources for this unit or from the back of each Deep Down Detectives Visual Aids book.)

NOTE: The Bible Cover pictures included in the Deep Down Detectives Visual Aids books cannot be created larger than 8.5" x 11". That means that they will be under-sized for a Bible Folder of the dimensions you are making. However, you can go online to the Deep Down Detectives curriculum and there is a pdf of a bigger version of these covers that will actually fit the size of this Deep Down Detectives “Bible” Folder.

### Directions

1. Lay out poster board with long side along the bottom.
2. Fold in 2" on each side.
3. Take packing tape and tape the folded in 2" flaps to the main section of the posterboard, all the way down.
3. Fold up 8 1/2" on the bottom of the poster board.
4. Use packing tape to tape this flap in place, all the way down.
5. Take scissors and snip through the tape where the flap is attached to the folder. This will give you a bit more room in the folder.
6. Fold the poster board in the middle to make the center fold.
7. Cut out the Bible Cover Pictures. If possible, laminate these. They will last longer.
- 8.. Glue the two cover pieces to the outside of the folder.

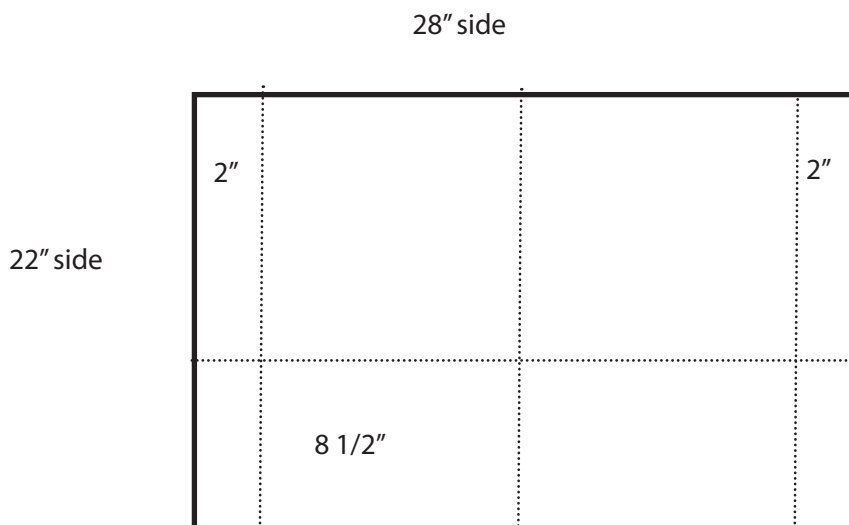

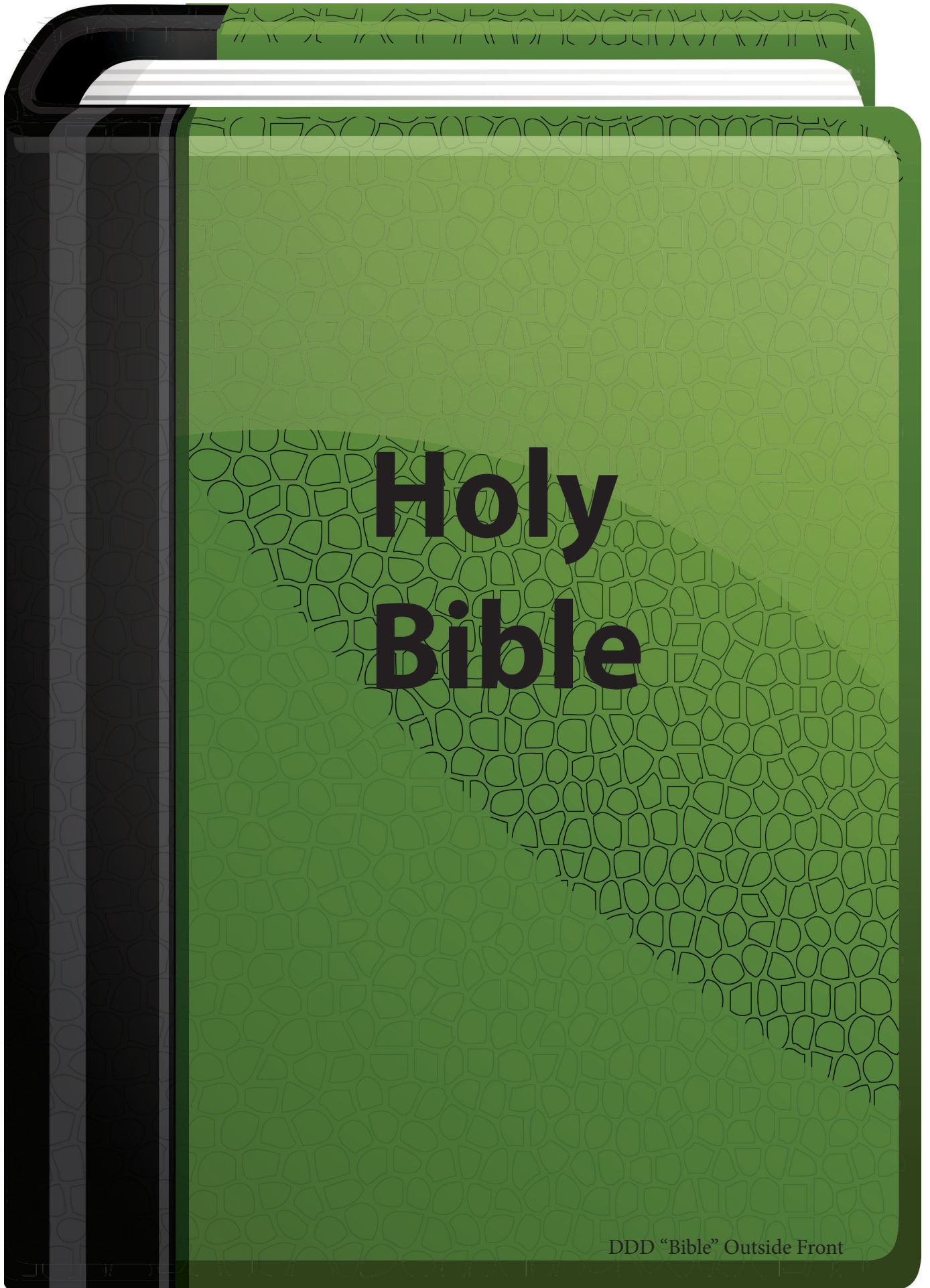

# Holy Bible

DDD "Bible" Outside Front







DDD "Bible" Outside Back

