

DEEP DOWN DETECTIVES

**70 Bible Truths
for Inquisitive 4-7's**



Unit 11

Core Curriculum, ESV

The God Who Saves



Curriculum for preschool and elementary age children,
training tools, music and other resources
are available for download or to order at:
www.praisefactory.org

© 2018 Praise Factory Media

This and many other resources are available online at www.praisefactory.org

Scripture quotations marked (NIV) are taken from the Holy Bible,
New International Version®, NIV®. Copyright © 1973, 1978, 1984 by
Biblica, Inc.™ Used by permission of Zondervan. All rights reserved worldwide.www.zondervan.com

Scripture quotations marked (ESV) are from The Holy Bible, English
Standard Version® (ESV®), copyright © 2001 by Crossway,
a publishing ministry of Good News Publishers. Used by permission. All rights reserved.

Scripture quotations marked HCSB are taken from the
Holman Christian Standard Bible®, Copyright © 1999, 2000, 2002, 2003, 2009
by Holman Bible Publishers. Used by permission. Holman Christian Standard Bible®,
Holman CSB®, and HCSB® are federally registered trademarks of Holman Bible Publishers.

Psalm 100

the psalm behind the name



(v.1) Make a joyful noise to the LORD, all the earth!

(v.2) Serve the LORD with gladness!

Come into His presence with singing!

(v.3) Know that the LORD, He is God!

It is He who made us, and we are His;

We are His people, and the sheep of His pasture.

(v.4) Enter His gates with thanksgiving,

And His courts with praise!

Give thanks to Him; bless His name!

(v.5) For the LORD is good;

His steadfast love endures forever,

And His faithfulness to all generations.

May this curriculum help you to be manufacturers of noisy joy unto the LORD (v.1). To sing (v.2), to know (v.3), and to worship Him with thanksgiving and praise (v.4), that the witness of His great faithfulness might continue through all generations (v.5).

The LORD is amazing! It Is God's Free Gift!

Constance Dever
June 27, 2016

Table of Contents

Getting to Know the Deep Down Detectives Curriculum	9
Getting Started with Deep Down Detectives	9
Deep Down Detectives Overview Flyer	11
Session Prep	13
Learning More about Deep Down Detectives Curriculum, by Resource	14
Learning More about Deep Down Detectives Curriculum, by Activity	16
Customizing the Curriculum: Know Yourself to Know What You Need	21
Customizing the Curriculum: Build-Your-Own-Curriculum Sandwich	22
Common Customizations: by Age Groups	23
Common Customizations: Teaching Situations	25
Maiden Voyage: Testing Out the Curriculum	27
The Real Launch: Implementing the Curriculum in Your Situation	28
Protect Your Investment: Tips on Storing the Curriculum for Future Use	29
Master Supplies List for All Deep Down Detectives Games (this list also included in Appendix B)	33
VBS, Camps and Other Programs	36
The Praise Factory Bible Truths across the Three Curriculums	41
CORE CURRICULUM FOR UNIT 11: THE GOD WHO SAVES	
How Can We Be Saved? It Is God's Free Gift...	
Bible Truth 1: When We Tell God Our Sins and Turn Away from Them	43
Session Prep	44
Unit Overview	45
Bible Truth Overview Sheet	47
Songs Track Numbers	48
Lesson Plan	49
Bible Story	61
Discussion Sheet	67
Bible Truth 2: When We Trust in Jesus as Our Own Savior	69
Session Prep	70
Unit Overview	71
Bible Truth Overview Sheet	73
Songs Track Numbers	74
Lesson Plan	75
Bible Story	87
Discussion Sheet	93
Bible Truth 3: When the Holy Spirit Works in Our Hearts	95
Session Prep	96
Unit Overview	97
Bible Truth Overview Sheet	99
Songs Track Numbers	100
Lesson Plan	101
Bible Story	113
Discussion Sheet	119

APPENDIX A: Songs	121
Track Numbers	122
Index of Songs	123
General Classroom Songs (Used every lesson, every unit)	125
Lyric	127
Sheet Music	131
Unit 11 Songs (Used every lesson throughout the unit)	135
Lyrics	137
Sheet Music	142
Bible Truth 1 Songs	149
Bible Truth 2 Songs	153
Bible Truth 3 Songs	157
APPENDIX B: Games	161
Games Index	162
Master Supplies List for All Deep Down Detectives Games	163
Bible Verse Games	167
Music, Movement & Memory Activities	180
Bible Story Review Games	193
APPENDIX C: Crafts and Take Home Sheets	207
Unit 11: Bible Truth 1 Crafts	209
Unit 11: Bible Truth 2 Crafts	231
Unit 11: Bible Truth 3 Crafts	251
APPENDIX D: Free Time Activity Suggestions	271
APPENDIX E: Resources to Make or Buy	277
Making a Big Question Box/Briefcase	278
Making a Flannelgraph Storyboard	279
Making Durable Storyboard Pictures	279
Making Durable Story Scene Pictures	279
Making the Deep Down Detectives Bible Folder	280

Deep Down Detectives Curriculum Resources

There are five companion resources for each of the sixteen units of Deep Down Detectives. Use whichever resources are useful to your setting. Deep Down Detectives resources are available as free, digital downloads at praisefactory.org, or for purchase as hard copies through amazon.com.

Make sure to check out the “Bits and Pieces” section of the Deep Down Detectives curriculum online. It has all of the resources separated out making it easy for you simply to pick, choose and print out whatever you want.

Deep Down Detectives Core Curriculum Book, ESV/NIV for each unit

The Deep Down Detectives Core Curriculum book contains the curriculum introduction, the lesson plans, stories, music, activities and take home sheets for each of the units.

Deep Down Detectives Visual Aids with Simple Story Scenes, ESV/NIV for each unit

This resource provides large, colorful signs of the key concepts used in the unit, PLUS, easy-to-use, colorful scenes that you hold up in sequence as you tell the story. The story text for each scene is printed on the bottom of each scene.

Deep Down Detectives Simple Story Scenes, ESV/NIV for each volume

This resource includes only 2-page overview for Bible Truth, the story scenes, and take home sheets. This is a great, basic resource for use at home and in many classroom teaching situations.

Deep Down Detectives Small Format Visual Aids, ESV/NIV (Small Format Storyboard Pictures) for each volume

This resource provides large, colorful signs of the key concepts used in the unit, PLUS, colorful storyboard (flannelgraph) pictures to cut out and use as you tell each story. These storyboard pictures are for use with storyboards at least 24" x 36" in size.

Deep Down Detectives Large Format Visual Aids, ESV/NIV (Large Format Storyboard Pictures) for each volume

This resource provides large, colorful signs of the key concepts used in the unit. It also provides colorful storyboard (flannelgraph) pictures to cut out and use as you tell each story. These storyboard pictures are for use with storyboards 36" x 48" in size.

All of these materials may be photocopied for non-commercial church, classroom or school use by licensed users.

Other Resources in the Praise Factory Family of Curriculum

Deep Down Detectives is the second in a family of three, inter-related curriculums:

- Hide 'n' Seek Kids (focus group: ages 2-4; adaptable range: ages 2-pre-K 5's)
- Deep Down Detectives (focus group: ages 4--6's; adaptable range: ages 3-2nd grade)
- PFI: (focus group: grades K-5th grade; adaptable range: pre-K 5's-6th grade)

Each curriculum teaches the same biblical themes, but are presented in greater depth as the children grow and develop. Together, the curriculums work like an expanding spiral of truth that returns to reinforce the same truths with each curriculum, yet leading the children to deeper understanding with each step up.

Learn more about these curriculums as well as other resources and ideas for reaching children with the gospel at: www.praisefactory.org.

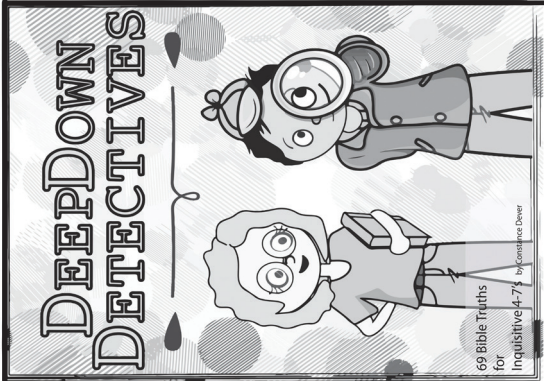
	<h1 style="text-align: center;">DEEP DOWN DETECTIVES</h1> <p style="text-align: center;">designed for ages 4-6, often used with ages 3-7</p> <p style="text-align: center;">the second of 3 curriculums in the Praise Factory family</p> <p style="text-align: center;">downloads and hard-copies available through www.praisefactory.org</p>	<h2 style="text-align: center;">DEEP DOWN DETECTIVES SESSION OVERVIEW</h2> <p>Session Format: Circle Times, Free Play and Your Choice of Activities Each session is structured around Circle Time and Free Play Time. Circle Times are used to introduce and review the concept, Bible verse, Bible story, and the ACTS prayer. (A prayer including <u>A</u>doration, <u>C</u>onfession, <u>T</u>hanksgiving, and <u>S</u>upplication related to the Bible truth they are learning.) Free play is not only enjoyable, but also helps to replenish attention spans and prepare the children for more group listening later in the session. Every session also includes lots of response activities that you may choose to use during free play time to add as much reinforcement as best suits your children. Each Deep Down Detectives session follows the same four-part format, as described here:</p> <p>PART 1: Getting Started A time to welcome the children to the class, enjoy free play, music, and/or play a Bible verse game.</p> <p>PART 2: Opening Circle Time The children are gathered together for their primary teaching time. The Big Question and Bible Truth (and related songs) are introduced. A listening assignment* is given, the Bible story told, then the listening assignment answered at the end of story time.</p> <p>PART 3: Free Play/Activity Time The children participate in free play and/or response activities.</p> <p>PART 4: Closing Circle Time The children gather together for a brief review of what they have learned and a closing prayer. Teachers give out take home sheets as children are dismissed.</p> <p>*As with the other two Praise Factory curriculums, Deep Down Detectives has a few detective-ish elements to it. (1) There is the "Big Question Briefcase" that contains the key concept visual aids and the Bible storyboard pictures that the teacher uses as he teaches. And (2), Each story is called "The Case of the" and comes with "Detective Dan's Listening Assignments." These are listening assignments to be solved as the children listen to the story. There are 3 different listening assignments--one for each of the 3 sessions of curriculum included with each Deep Down Detectives Bible Truth. These questions are especially good for use with three-year-olds or older preschoolers.</p> <p>Session Length The resources for each Deep Down Detectives session--as described in the lesson plan--are designed for a 60 to 90 minutes session. However, they can be easily tailored to fit a shorter or longer session.</p>
<h2 style="text-align: center;">DEEP DOWN DETECTIVES... AT A GLANCE</h2> <ul style="list-style-type: none"> • Teaches the 16 Biblical (theological) themes used in all three Praise Factory curriculums, but in greater depth than in Hide 'n' Seek Kids. Each of these themes is presented as a "Big Question and Answer." • Each theme is taught as a series of Bible truths that develop the theme. There are 69 Bible truths in all. • There is one Bible story and one Bible verse for each of the 69 Bible truths. All of the Bible verses are set to music, which can be a great aid in learning and remembering them. • There are three sessions of curriculum per Bible truth. Use as few or as many as you want. Each is jam-packed with activities. • The multiple sessions give children the time they need to really learn each truth. The new activities keep the learning fresh each session. • The curriculum for each Bible truth comes with a fully-scripted lesson plan, beautiful storyboard pictures, games, crafts, take-home sheets, and lots of music. • The curriculum is flexible and is easily adaptable to many different teaching settings. • Both downloads and hard copies available. 		

Note: *If desired, you can start out each of the 16 units of Deep Down Detectives with one session (or more) from Hide 'n' Seek Kids curriculum. This creates a nice introduction to the over-arching theme for each unit. It would also add 16 or more sessions to the curriculum.

DEEP DOWN DETECTIVES SCOPE AND SEQUENCE			
UNIT	BIBLE TRUTHS TAUGHT	UNIT	BIBLE TRUTHS TAUGHT
Unit 1: The God Who Reveals Himself Q: How Can I Know What God Is Like? A: He Shows Me What He's Like!	1. By the Heart He Gave Me to Know and Love Him 2. In Everything I See All Around Me 3. In the Bible, the Perfect Word of God 4. Through His Very Own Son, Jesus Christ	Unit 9: Jesus Christ, Immanuel, God with Us Q: What Did Jesus Come to Do? A: Jesus Came to Bring Us to God!	1. He Left His Home in Heaven to Save Us 2. He Never, Ever Disobeyed God 3. He Taught about God and Did Amazing Things 4. He Died on the Cross for His People's Sins 5. He Rose from the Dead 6. He Went Up to Rule in Heaven
Unit 2: God's Wonderful Word, the Bible Q: What's So Special about the Bible? A: It Alone Is God's Word!	1. God Made Sure It Was Written Down Just Right 2. It Tells Us about God and His Plans 3. God Uses It to Save His People 4. God Uses It to Change His People	Unit 10: The Holy Spirit: The Indwelling God Q: What Does the Holy Spirit Do in God's People? A: He Changes Their Hearts!	1. The Holy Spirit Lives in God's People 2. The Holy Spirit Gives God's People Courage 3. The Holy Spirit Gives God's People Wisdom 4. The Holy Spirit Builds God's Church
Unit 3: The Good News of God, the Gospel Q: What Is the Gospel? A: Salvation through Faith in Jesus Christ!	1. God Made Us and We Should Obey Him 2. We Have All Disobeyed God and Deserve His Punishment 3. God Sent Jesus to Pay for God's People's Sins 4. God Saves All Who Repent of Their Sins and Trust in Jesus	Unit 11: The God Who Saves Q: How Can We Be Saved? A: It Is God's Free Gift!	1. When We Trust in Jesus as Our Own Savior 2. When We Tell God Our Sins and Turn Away from Them 3. When the Holy Spirit Works in Our Hearts
Unit 4: The God Like None Other Q: Can Anybody Tell Me What the LORD Is Like? A: He's Not Like Anyone Else!	1. He Is a Glorious Spirit 2. He Is the One, True God 3. He Is God the Father, Son and Holy Spirit: One God, but Three Persons 4. He Is Everywhere, All the Time 5. He Knows Everything There is to Know 6. He Is Perfectly Holy, Purely Good 7. He Can Do Anything He Wants to Do 8. He Is Always Faithful, Through and Through	Unit 12: God's People Live for Him Q: How Should God's People Live? A: They Should Live Like Jesus!	1. By Asking God for His Help 2. By Loving Him Most of All 3. By Loving Other People as God Has Loved Them 4. By Trusting God and Being Happy with What He Wants 5. By Learning God's Word and Obeying It 6. By Saying "No" to Disobeying God 7. By Telling the Good News of Jesus 8. By Making Much of God
Unit 5: God, the Good Creator Q: Can You Tell Me What God Made? A: God Made All Things Good!	1. He Made Everything Good in Heaven and Earth 2. He Made People in a Special Way	Unit 13: The Sustaining God Q: Why Do God's People Keep Believing in Him? A: It Is God's Sustaining Grace!	1. God Alone Sustains His People 2. God the Father Promises to Help His People 3. Jesus Provides God's People with Everything They Need to Live for Him 4. The Holy Spirit Works in His People 5. The Word of God Grows God's People 6. God Uses His People to Strengthen and Comfort Each Other
Unit 6: God, the Just and Merciful Q: How Did Bad Things Come into God's Good World? A: Bad Things Came Through Sin!	1. When Adam and Eve Chose to Disobey God 2. When It Spread to the Whole World	Unit 14: The God Who Delights in Our Prayers Q: How Does God Want Us to Pray? A: Every Night and Day!	1. He Wants Us to Praise Him 2. He Wants Us to Confess Our Sins to Him 3. He Wants Us to Thank Him 4. He Wants Us to Ask Him to Do Great Things
Unit 7: The God Who Saves Q: How Can We Be Saved? A: It Is God's Free Gift!	1. When We Tell God Our Sins and Turn Away from Them 2. When We Trust in Jesus as Our Own Savior 3. When the Holy Spirit Works in Our Hearts	Unit 15: God's People Gather Together Q: Why Do God's People Go to Church? A: To Worship God and Love One Another!	1. By Praising God for Jesus' Win over Death 2. By Learning from God's Word, the Bible 3. By Caring for Each Other's Needs 4. By Telling What God Has Done and Praying 5. By Baptizing People Who Trust in and Live for Jesus 6. By Remembering Jesus Died to Save Them
Unit 8: The God Who Loves Q: What Is God's Love for His People Like? A: It's More than They Could Ever Deserve!	1. He Gave His Son, Jesus to Save Them 2. He Always Takes Care of Them 3. He Uses Their Sadnesses for Good 4. He Will Never Stop Loving His People	Unit 16: Jesus, the Returning King Q: What Will Happen When Jesus Comes Back? A: God Will Make Everything New!	1. Jesus Will Judge All People Fairly 2. God's People Will Live Happily with God Forever

Session Prep (especially good for newbies!)

Pray!



Pray for the Holy Spirit to be at work in your and the children's hearts.

Review



If new to the curriculum, look at the **Getting Started with Deep Down Detectives section of the Core Curriculum book**. (p.5) It will be especially helpful to read through the Deep Down Detectives section of **The Praise Factory Tour: Extended Version Book**. This is a visual way to understand what goes on in the classroom. (A pdf of the book is found in the samples section on the website.)

Look through and Learn the Lesson



Read over **lesson plan**. Practice any **songs or action rhymes** you are using. Choose/make up motions to go with these. Choose less with younger children and more with older preschoolers. **Practice the lesson with the visual aids** and using the Big Question Box/Briefcase.

Read and Rehearse the Bible Story with Pictures



Read the Bible story from the Bible. Read the curriculum version. Practice telling it with the storyboard pictures. (If you have not previously laminated the story pictures, do that now.) Or, rehearse it from the Simple Story Scenes, if you are using those.

Let There Be Music



Download the music and listen to the songs. Choose which of the songs you will use with the children. If using live musicians, make sure they have the sheet music (Appendix A, Core Curriculum book).

Put the Props in Place



1. Prepare your Visual Aids. Put the Big Question, Unit Bible Truths, Bible Truth, Bible Verse, and Listening Assignment signs, as well as the Bible Story script in one side of the Bible folder.
2. Get out your storyboard. If using Simple Story Scenes, put these in your Bible Folder. Or, if using the individual storyboard figures, put all background pictures in place (they have a BG by the number). Put the rest of the storyboard pictures (these have a SB by the number) in order of use in the other side of the Bible folder.
3. Put the DDD Bible Folder as well as the Big Question sign in the Big Question Box/Briefcase and shut it. If your box/briefcase has locks and you want to use the unlocking the box as part of your session, lock it now....but make sure you have the key or know the code first.
4. Prepare the music CD or sheet music or mp3 device for use in your session.

Set Out Free Play Activities



Choose and set up free time activities you will use with the children. Choose a variety of different activities that will be enjoyed by different types of children. Rotate the activities you provide to keep them interesting and fresh to your children. (Suggestions in Appendix D, Core Curriculum books.)

Prepare Any Activities



Choose which (if any) of the Bible Truth games and crafts activities you want to use in the session. Bear in mind your time frame as well as the developmental abilities and attention span of your children as you decide which/how many to prepare. **Look over the Discussion Sheet** and choose a few questions you might use to spark discussion with the children as they do their activities (especially good for ages 3's+). Pray for God to give you opportunities to talk about these things with the children.

Let Them Take It with Them



Make copies of the craft/take home sheets, if you are not already using them as one of your activities. You may also want to make copies of the story (see take-home version of each story included in Appendix C with the other take home resources) to have for parents to use with their children at home. There's a link on each craft/take home sheet to the story, if you don't make hard copies.

Store It



After your session is over, collect the resources and store them for future use. This curriculum can be used over and over for years to come.

Learning More about Deep Down Detectives Curriculum, by Resource

The extra-depth information starts here! This section will describe important features of the Deep Down Detectives curriculum. Look at each resource in the Deep Down Detectives Core Curriculum and Visual Aid books as you read below. **This first section takes a look at the major resources used in presenting the curriculum.**

<p>Scripted Lesson Plan</p>  <p><i>Found in the Core Curriculum books</i></p>	<p>There are three lessons of curriculum provided for each Bible Truth. Since much of the text is the same for all three lessons, only one lesson plan is needed. The different activities for each lesson are noted where they occur. The lesson plans are fully-scripted. This helps even the most inexperienced teacher to know what to say and do. They train your teachers in what to say and do, every step of the way. Notice the green squares with numbers found in the left side bar of the lesson plan. These are references to the visual aids the teacher can use with the children as she teaches.</p>
<p>Visual Aids</p>  <p><i>Resources found in the Deep Down Detectives Visual Aids books</i></p>	<p>Visual aids are very important in the Deep Down Detectives curriculum. They help the children learn, and keep them focused and interested. Visual aids also help even the newest teacher teach with greater ease. All of the visual aids are used with the Big Question Box/Briefcase and are revealed as the lesson progresses. They include the Big Question and Answer sign, the Unit Bible Truths sign, the Bible Truth sign, the Bible Verse sign, the Listening Assignments (used as the children listen to the Bible story), and the storyboard pictures used with the Bible story.</p>
<p>Big Question Box/Briefcase</p>  <p><i>Directions for making this are found in the back of the Deep Down Detectives Core Curriculum books</i></p>	<p>The Big Question Box/Briefcase is a simple box with a lid that you buy or make; or, you can use a briefcase with a combination lock (kids love this!). Inside the Big Question Box/Briefcase are the props for key teaching concepts (Big Question and Answer; Unit Bible Truths, the Bible Truth concept, the Bible verse and Bible story. While not absolutely necessary, the Big Question Box adds a lot of interest to the lesson.</p>
<p>Deep Down Detectives "Bible" Folder</p>  <p><i>Directions for making this are found in the back of the Deep Down Detectives Core Curriculum and Visual Aids books</i></p>	<p>The Deep Down Detectives "Bible" Folder is a large, homemade folder made from a 22" x 28" piece of poster board. Images for the front and back of this mock Bible can be glued in place. 8.5" x 11" front and back cover images are included in the Deep Down Detectives Visual Aids in the back. Larger versions of the front and back covers are found online for download with the resources for each unit.</p> <p>Inside this over-sized folder, the teacher places the Bible Verse, the Listening Assignment for the Bible story, the text to the Bible story and the storyboard pictures. The point of this Bible folder is for children to begin to grasp that the truths they are learning come from the Bible.</p>
<p>Simple Story Scenes, Storyboard & Storyboard Pictures</p>  <p><i>Directions for making these are found in the back of the Deep Down Detectives</i></p>	<p>Beautiful storyboard pictures have been created for you to put up on a feltboard to bring the story alive. (These figures are also used in the Bible Story Review Game.) The storyboard pictures are found in the Deep Down Detectives Visual Aids Book for each unit. See Core Curriculum Appendix E for preparation instructions.</p> <p>Simple Story Scenes are the easiest way to use the pictures. Each story is simply told with book-like illustrations and story text along the bottom.</p> <p>If you want a more traditional flannelgraph approach, choose the Storyboard Pictures. These are individual figures that let you build your own scene and allow kids to help put up the pictures. Fun, but they are more work. There are two, different sizes of storyboard pictures you can choose from. Small Format for the smaller class or home setting. Large Format, for a larger class.</p>

Learning More about Deep Down Detectives Curriculum, by Resource

Two, Colorful Ways to Present the Story: Story Scenes OR Storyboard (Flannelgraph) Pictures



Directions for making these are found in the back of the Deep Down Detectives Core Curriculum and in the Visual Aids books

Beautiful **pictures** have been created to help you bring the story alive.

The Deep Down Detectives Visual Aids and Story Scenes Book for each unit is the easiest way to access these pictures. Ten, colorful, 11" x 17" scenes with text on back can be held up as you tell the story. Each comes as two, 8.5" x 11" sheets which are taped together to create each 11" x 17" scene. Quick to prepare. Easy to use.

Or, you can use the **Storyboard Pictures**, which are individual, flannelgraph pieces that you put up on a felt storyboard as you tell the story. There are **two, different sizes of storyboard pictures** you can choose from. **The pictures in the Deep Down Detectives Small Format Visual Aids books fit on 24" x 36" to 36" x 48" storyboards.** Plenty for a smaller class or home setting. Or, for **larger classroom settings**, choose **The pictures in the Deep Down Detectives Visual Aids (Large Format Storyboard pictures) books work best on a storyboard that is AT LEAST 36" x 48".**

Those with less prep time or with less experience teaching may feel more at ease with the Storybook Scenes. The storyboard pictures do take time to cut out and laminate. You do need to take time to learn to tell the story with them. But, the children love watching the story unfold as you put up the storyboard pictures. And, they can take an active role in helping put them up, which is of great, educational benefit. We (CHBC) actually use both. We love to tell the story with the Story Scenes; then, we have the children review the story by reconstructing it with the Storyboard Pictures. They are like a big puzzle that kids love to put together. Either or both are all great options.

Deep Down Detectives Music



Songs for each unit found in the back of the Core Curriculum book

Lyrics and sheet music for the songs used with each unit are actually included within the Deep Down Detectives Core Curriculum books in Appendix A.

Deep Down Detectives Audio mp3's



Resources found online only with the resources for each unit

The audio music for each unit is **included in a zip file** found on the Praise Factory website with the resources for each Deep Down Detectives unit.

Download the zip file from the website to a desired location on your computer. Open the zip file by choosing the "extract" option (often shows up when you right click your mouse over the file.) Once they are extracted, you can access them.

You also can play the songs right off of the website from the Deep Down Detectives "Just Music" section.

Or, you can download the QR code sheet of songs used with each Bible Truth.

Learning More about Deep Down Detectives Curriculum, by Activity

This section describes the activities offered in the Deep Down Detectives curriculum, in order of use. Look at them in the Deep Down Detectives Core Curriculum and Visual Aids books as you read below.

<p>Intake Activities</p> 	<p>These are activities that help the children settle in their class and get ready for learning. They are open-ended so that any child can join in as they are checked into class. Younger children typically do a free time activity.</p> <p>Older children typically play a Bible Verse Memory Game or take part in the Sing-along Music Time. Adding the Music, Movement & Memory Activity to the singing can be especially enjoyable for these children.</p> <p>Both the Bible Verse Memory Game and the Music, Movement & Memory Activity are some of the games included in the Response Activities section of the lesson plan. There are three sets of these games suggested, enough for a new set of game for each of the three lessons included with each Bible Truth. Game directions are found in Appendix B of each Deep Down Detectives Core Curriculum book.</p>
<p>The Classroom Song</p> 	<p>Transitions between activities can be difficult, particularly for preschoolers. The Classroom Song is a simple song with four verses used at transition times to make transitions easy and fun.</p> <p>Verse 1: The Gathering Verse invites the children to gather together to worship God. Verse 2: The Go and Play Verse dismisses the children to play time. Verse 3: Time to Go & Tell Verse transitions the children to Closing Circle Time,. It is used not only to help them remember what they have learned in class , but also to go and tell others what they've learned Verse 4: What's Our Big News Verse asks the children to think about what they will go and tell others as they are dismissed.</p> <p>The lyrics to the Classroom Song are included in the lesson plan. Large format lyrics and sheet music are included in Appendix A of each Deep Down Detectives Core Curriculum book. An audio version of each verse is included in the unit music.</p>
<p>The Deep Down Detectives Theme Song</p> 	<p>Circle Time opens with the curriculum theme song. It reminds the children what their learning time is about. The lyrics to the Classroom Song are included in the lesson plan. Large format lyrics and sheet music are included in Appendix A of each Deep Down Detectives Core Curriculum book. The song audio included with the rest of the unit songs.</p>
<p>The Classroom Rules Song</p> 	<p>A major challenge and important goal with preschoolers is teaching them how to act in a more formal, group teaching setting. Remember this and do not let yourself become frustrated. Your work with the children now will make way for easier teaching as they get older. Reviewing simple and clear classroom rules, then praying for God's help with the children is a great way to start every session During the rest of the session, you may want to refer back to the rules, praising the children when they are keeping them well or reminding them of the rules when addressing problems.</p> <p>The Classroom Rules Song provides a simple, fun to sing/say chant of class rules. It helps remind children of the behavior expected of them in class.</p> <p>The lyrics to the Classroom Rules Song are included in the lesson plan. Large format lyrics and sheet music are included in Appendix A of each Deep Down Detectives Core Curriculum book. The audio for this song is included in the unit music.</p>

Prayers

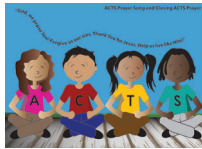

Two prayers are used in each session: an **Opening Prayer** and an **Unit ACTS** prayer.

The Opening Prayer stays the same for every session of Deep Down Detectives. It is a prayer asking for God’s help to keep the class rules and to learn about Him.

The Opening Prayer can be introduced with the **“Let’s Pray!” Song/rhyme**.

The ACTS Prayer changes with each Bible Truth. It is called an ACTS prayer because it incorporates four elements of prayer: Adoration (praising God for who He is); Confession (asking forgiveness for our sins); Thanksgiving (thanking God for what He’s done, especially through Jesus); and, Supplication (asking God to do great things). It centers around the Bible Truth the children are learning. The ACTS prayer for each Bible Truth can be introduced by the **ACTS Prayer Song**, which helps familiarize the children with the four elements of prayer represented by A,C,T, and S.

The lyrics to “Let’s Pray” and the “ACTS Prayer Song” **are included in the lesson plan. Large format lyrics and sheet music are included in Appendix A of each Deep Down Detectives Core Curriculum book. The audio for these songs is in the unit music.**

The Big Question & Answer



The Big Question Box Song



The Big Question and Answer is introduced by the use of a 8½”x 11” two-sided **Big Question and Answer sign**. This sign is hidden in **The Big Question Box/Briefcase**, a simple box with a lid you can buy or make; or, a briefcase. (Suggestions for making or buying one included in the Core Curriculum books in Appendix E).

The children sing/say the **Big Question Box/Briefcase Song**, then the teacher or a designated child opens the box/briefcase and gives it to the teacher to hold up and read to the children. The teacher and children then sing the **Big Q & A Song**: the Big Question and Answer set to the tune of a familiar nursery rhyme.

The words to the Big Question Box Song **are included in the lesson plan. Large format lyrics and sheet music are included in Appendix A of each Deep Down Detectives Core Curriculum book. The audio for this song is included the unit music.**

Big Question Action Rhyme and Song



The meaning of the Big Question and Answer is explained by use of an action rhyme. The action rhyme includes actions that you can do as you say it. Use as few or as many of the actions as you deem appropriate for your children.

Or, you can sing the **Big Question Song**, which incorporates the same concepts into a song.

The lyrics to the Big Question Song **are included in the lesson plan. Large format lyrics and sheet music are included in Appendix A of each Deep Down Detectives Core Curriculum book. The audio for this song is in the unit music.**

Unit Bible Truths



Having learned the Big Question and Answer for the unit, now it’s time to introduce the Bible Truths about this Big Question that the children will be learning. The teacher holds up the **Unit Bible Truths sign** that show all the Bible Truths in the unit. (There are anywhere from two to eight truths in a unit). He tells the class that these are the truths they will be learning about the Big Question, one by one. This helps the children to group the truths together and review what they are as they progress through the unit.

The Bible Truth Clue Sign



Having shown the children all the Bible Truths, the teacher is now ready to focus in on the one of the Bible Truths. The teacher/designated child will take the **Bible Truth Clue sign out of the Big Question Box/Briefcase** and show it to the class. At first, he only shows them the words on the top of the sign (use one hand to cover up the answer along the sign's bottom). He reads the words along the top, emphasizing the word that is missing. The class listens to the clue hint and works together to come up with the missing word. The teacher reveals the answer, then reads the meaning of the Bible Truth off of the back of the sign (or from the lesson plan.) There are three lessons for each Bible Truth, allowing the children to learn and master the concept before moving onto the next one.

The Bible Chant



The kids prepare to hear teaching from the Bible by singing/saying **the Bible Chant Song**. This is a simple jingle that reminds the kids that the Bible is very special because it alone is God's Word.

The lyrics to the Bible Chant **are included in the lesson plan. Large format lyrics and sheet music are included in Appendix A of each Deep Down Detectives Core Curriculum book. The audio for this song is in the unit music.**

The Deep Down Detectives "Bible" Folder



After singing the Bible Chant song, the teacher/designated child pulls out the **Deep Down Detectives "Bible" Folder** from the **Big Question Box/Briefcase**. As explained previously, the point of this Bible folder is for children to begin to grasp that the truths they are learning come from the Bible. The Deep Down Detectives "Bible" Folder is a large, homemade folder made from a 22" x 28" piece of poster board. Images for the front and back of this mock Bible can be glued in place. Inside this over-sized folder, the teacher places **the Bible Verse, the Listening Assignment for the Bible story, the text to the Bible story and the storyboard pictures.**

The Bible Verse and Song



The first thing that the teachers pulls out of the "Bible" folder in the Bible verse. Only one Bible verse is taught with each Bible truth. This gives the children three lessons to really learn the verse and its meaning--not just hear it and forget it. The Bible verse is reinforced even more through **the Bible Verse Song**. This song is used as part of the regular teaching time in Circle Time, as well as in the **Music, Movement and Memory activities**, described next. These activities provide even more opportunities for learning the verse.

The lyrics to the Bible Verse Song **are included in the lesson plan. Large format lyrics and sheet music are included in Appendix A of each Deep Down Detectives Core Curriculum book. The audio for this song is in the unit music.**

The Bible Story and Resources



Only one Bible story is used in each Bible truth. Instead of tiring of hearing the same story for three lessons, the children are delighted to have a chance to master it.

Optional actions/questions are woven into the story text. Beautiful **storyboard pictures** have been created for you to put up on a feltboard to bring the story alive. (These figures are also used in the **Bible Story Review Game**.) The storyboard pictures are found in the **Deep Down Detectives Visual Aids books. Or, use Simple Story Scenes.**

Directions for making a homemade storyboard board and for making durable storyboard pictures are found in the Core Curriculum books.

While the same Bible story is used for all three lessons, there is a different "listening assignment" for each lesson. These are called **"Detective Dan's Listening Assignments."** (These listening assignments will probably be **too much for two year olds; can be useful in developing a three year olds listening skills; and, and are great for children older than this.**

Finish your story time by answering the listening assignment; sharing the gospel, and praying the ACTS (Adoration, Confession, Thanksgiving, Supplication) prayer; and, two response songs.

Story Response Songs



There is a hymn and a praise song that you may choose to close Opening Circle Time with. Each unit features a different pair of response songs, related to the unit Big Question and Answer. This gives the children many lessons to learn these songs. A short unit tie-in description is included with each song.

The words to these two songs **are included in the lesson plan. Large format lyrics and sheet music are included in Appendix A of each Deep Down Detectives Core Curriculum book. The audio for this song is in the unit music.**

Response Activities: Games and Crafts



After Opening Circle Time, the children can either enjoy free play (**see Core Curriculum Appendix D for suggestions**) or one of the many game or craft activities. The games and crafts are all created to help reinforce the truths the children have just learned in Circle Time. These are all created to help reinforce the truths the children have just learned in Circle Time.

There are **three, different games suggested for each lesson:** the Bible Verse Game, the Bible Story Game, and the Music, Movement & Memory Activity. And, there is a **simple coloring craft/take home sheet for each of the three lessons, as well as three extra crafts that can be used at any time.**

Because there are so many response activities, some teachers like to incorporate some of them as Intake Activities at the beginning of a session.

Let's look at each of these activities, starting on the next page.

Response Activities: Games



When Opening Circle Time ends, the children can either enjoy free play or one of the many game or craft activities. **The games are referenced in the lesson plans, but are listed in Appendix B at the back of each Deep Down Detectives Curriculum book. The crafts are referenced in the lesson plan, but instructions and any pages to be photocopied are found in Appendix C at the back of each Deep Down Detectives Curriculum book.**

Let's look at the games, then the crafts.

The Bible Verse Game



The Bible Verse Game helps the children learn the Bible verse and think about what it means. **The Bible verse games are referenced in the curriculum, but listed in Appendix B in each Deep Down Detectives Core Curriculum book.**

The Bible Story Review Game



The **Bible Story Review Game** helps the children think about what they learned in the story. It uses the **Storyboard Pictures** from the Bible story. **The Bible Story games are referenced in the curriculum, but listed in Appendix B in each Deep Down Detectives Core Curriculum book.**

Music, Movement & Memory Activity



The Music, Movement & Memory Activities have the children do certain movement or use **simple homemade (or store bought) musical instruments**, as they sing songs or say the Bible verse. A **simple hymn** and **praise song** as well as the **Bible Verse Songs** and **Big Question Song** are suggested for use. A short blurb describing how each song ties in with the Bible Truth concept is given. **The Music, Movement & Memory Activities are referenced in the curriculum, but listed in Appendix B in each Deep Down Detectives Core Curriculum book.**

The lyrics and sheet music to these songs are included in the Core Curriculum books. The audio for these songs is found with each unit's music.

All three of these activities are part of a **collection of games that can be assembled ahead of time, then stored** for use throughout the curriculum on a rotation basis. This makes it easy to keep each lesson active and fun, but with less prep work. **A complete list of supplies need to make the games is included in later in this chapter and in Appendix B of each Core Curriculum book.**

Response Activities: Crafts

Coloring Pages/ Take Home Sheets







There are both coloring pages/take home sheets as well as a few extra crafts available with each Bible Truth. **The crafts are referenced in the lesson plan, but instructions and any pages to be photocopied are found in Appendix C at the back of each Deep Down Detectives Core Curriculum book.**

A coloring page is provided for each of a Bible Truth's three lessons. On the back of each page are the key concepts, a few questions; an ACTS prayer; and, a song/s for parents to use with their children that act as a take home sheet. There is a different emphasis for each lesson's coloring sheet that corresponds with the listening assignment for the lesson:



- Lesson 1 Coloring Sheet Emphasis: The Bible Truth
- Lesson 2 Coloring Sheet Emphasis: The Bible Verse
- Lesson 3 Coloring Sheet Emphasis: The ACTS Prayer

While these are simple, coloring sheets, they can be easily turned into something more. Upgrade your coloring sheet to a more interesting craft by offering simple embellishments, such as jiggly eyes, craft sand, glitter, glitter glue, colored paper dots (made with a hole punch), fabric scraps, etc. Make cut-to-size glued-on clothes, hair, etc. for characters by using a copy of the coloring sheet, cutting out the selected portions and making them the patterns for whatever you want to cut out of fabric, paper, foil, etc.



<p>Response Activities: Crafts</p> <p>Extra Crafts</p> 	<p>With each Bible Truth, there are three extra crafts included for use at any time.</p> <p>These are a Go-and-Tell Craft; a Bible Story Coloring Picture and a Bible Story Puzzle (which is the Storyboard Picture Placement page from the story, which you can cut out into the appropriate number of puzzle pieces for your children, then re-assembled by them).</p> <p>Like the other crafts in the curriculum, these extra crafts are referenced in the lesson plan, but instructions and any pages to be photocopied are found in Appendix C at the back of each Deep Down Detectives Core Curriculum book.</p>
<p>Response Activities: Discussion Sheet</p> 	<p>The discussion sheet contains questions about the key concepts used in the Bible Truth. These can be used to spark good conversation as the children are coloring. They can also be used as part of the games and other activities to add even more depth.</p> <p>They are most appropriate for use with children ages 3 and up.</p>
<p>Take Home Resources</p> <p>Coloring Pages/ Take Home Sheets</p>  <p>Take Home Version of the Bible Story</p> 	<p>There is a different coloring page/take home sheet for each of the three lessons provided for every Bible Truth. Each take home sheet has a slightly different emphasis, but they all include the key concepts and a few questions. They also tell parents where they can find the full script to Bible story and other resources on the Praise Factory website (in the Parents' Resource section for the curriculum), if they want to use them at home with their children.</p> <p>The front side is the coloring page and the back side is the take home sheet. The coloring pages/take home sheets are referenced in the lesson plan, but the pages to be photocopied are found in Appendix C at the back of each Deep Down Detectives Core Curriculum book.</p> <p>There is also a take home version of the story that you can give out along with the take home sheets. This is also available online in the Deep Down Detectives parents' resources section.</p> <p>This version of the Bible story is referenced in the lesson plan, but is included in Appendix C at the back of each Deep Down Detectives Core Curriculum book. It is also available online in the Deep Down Detectives Parent Resource section, as parents are reminded on each take home sheet along the bottom.</p>
<p>Music Resources</p> <p>Lyrics and Sheet Music</p>  <p>audio mp3's of the songs</p>	<p>Lyrics and sheet music for the songs used with each Bible Truth are included within the Deep Down Detectives Core Curriculum books.</p> <p>Each lesson plan includes the lyrics to the core songs used with each Bible Truth. Large format lyrics and sheet music for the songs is included in Appendix A of each Core Curriculum book.</p> <p>Frequently, the lesson plan references extra songs. The lyrics and sheet music to these extra songs are only found in Appendix A with the other unit songs.</p> <p>The songs can be downloaded from the praisefactory.org website. There are 16 zip files of mp3s of songs, one for each of the 16 Deep Down Detectives units. Or, you can download the QR code sheets of links to the songs.</p>

Customizing the Curriculum: Know Yourself to Know What You Need



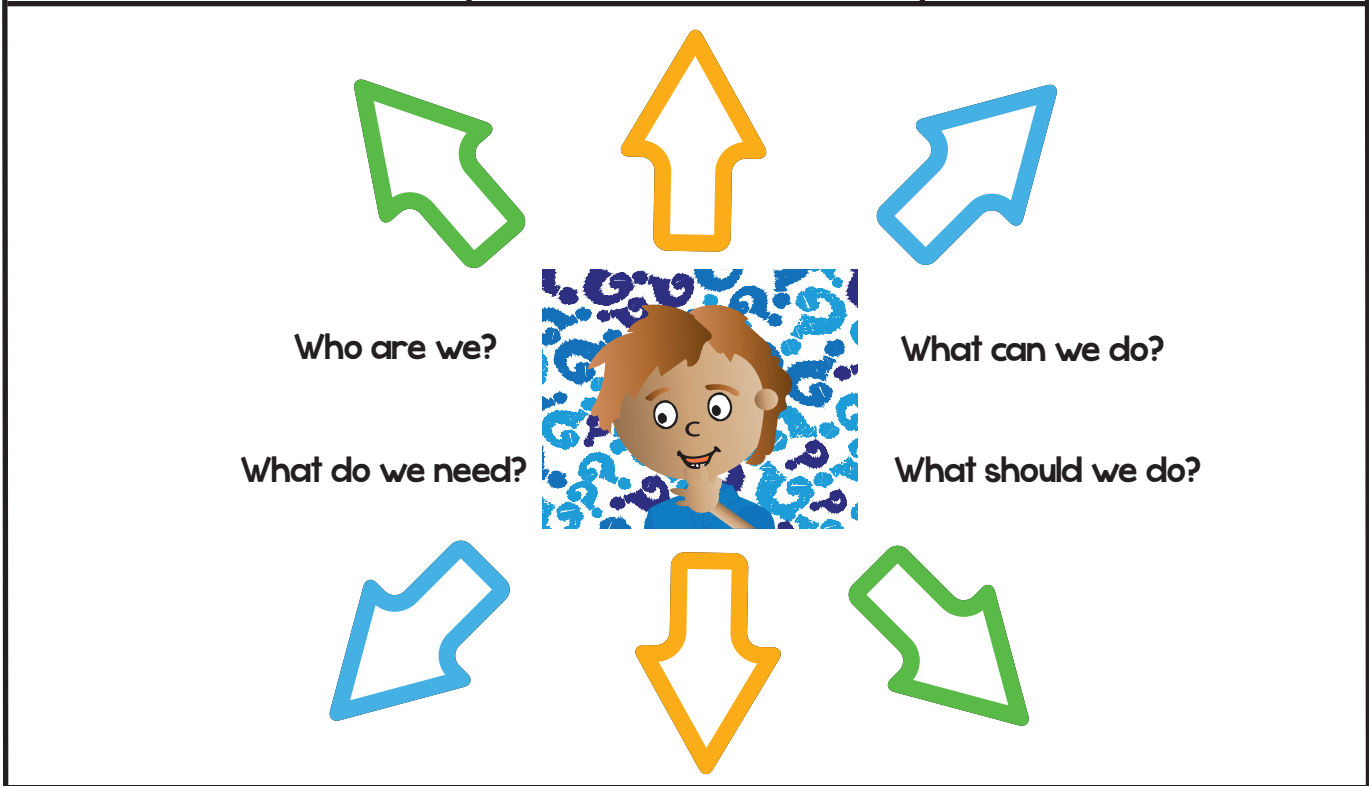

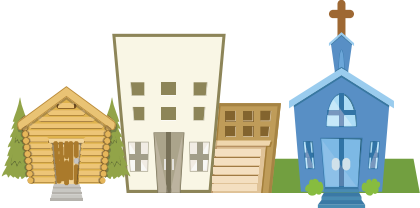

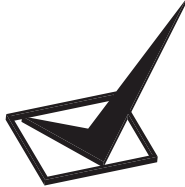

A good, curriculum custom-fit starts with thinking carefully about those involved. Here are six, key factors to consider. (The Children’s Ministry Questionnaire will guide you through these issues in much greater depth.)

 <p>Your Children’s Abilities</p>	 <p>Your Teachers’ Agility</p>	 <p>Your Time Capacity</p>
<ul style="list-style-type: none"> + readers/pre-readers? + age groupings in the same class + attention span + exposure to the gospel? + etc. 	<ul style="list-style-type: none"> + teaching experience + experience with children + classroom experience + their own spiritual maturity + etc. 	<ul style="list-style-type: none"> + Thirty minutes or one hour? + Once a week/five days a week? + A camp session/a V.B.S + School year/a full year? + etc.

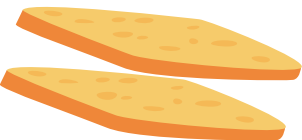

 <p>Your Teaching Locality</p>	 <p>Your Ministry Priorities</p>	 <p>Your Practicalities</p>
<ul style="list-style-type: none"> + Home, church or school? + Urban, suburban or rural? + Storage space available? + Classroom size? + etc. 	<ul style="list-style-type: none"> + Who gives you spiritual oversight? + What do they want you to teach? + Are they willing to look over the curriculum/help find and screen teachers? + etc. 	<ul style="list-style-type: none"> + What is your budget? + Who will prepare the curriculum? + How much time do they have? + Is there anyone willing/able to oversee the start up and implementation of a new curriculum?

Customizing the Curriculum: Build-Your-Own-Curriculum Sandwich

		<p>You've thought about who you are, what you need, what you can do, and what you can should do. Now it's time to customize your own curriculum version. We like to think of this process as similar to creating your favorite sandwich. Start with what you know has to be there, then add in extras until you get just what you want. You might be a "meat-only" sandwich, needing only the very basics of the curriculum. Or, you want "the works"--the whole curriculum, just as it is written. Many people use something in between. The important thing is to keep in mind the specifics of your teachers; your children; your time constraints; and, your ministry situation. Then build your own version of Deep Down Detectives that works best for you. Bon appetit!</p>
<p>1. Start with the Meat: Core Curriculum</p> 	<p>Resources:</p> <ul style="list-style-type: none"> • Big Question and Answer • Bible Truth • Bible Verse • Bible Story 	<p>These are the backbone of biblical truth for the curriculum. You really only have to have these. Everything else is extra!</p>
<p>2. Choose Your Cheese: Response Activities</p> 	<p>Resources:</p> <ul style="list-style-type: none"> • Bible Memory Game • Bible Story Review Game • Music, Movement & Memory • Crafts 	<p>Response activities are second in importance only to the "meat." They are enjoyable, hands-on activities that help the children learn and retain the "meat" of biblical truths.</p>
<p>3. Add the Lettuce: Intake Activities</p> 	<p>Resources:</p> <ul style="list-style-type: none"> • Free Play • Activity Centers • Unit Songs • Bible Memory Game 	<p>Intake Activities are a nice addition to your curriculum "sandwich", but you don't have to have them. They often help the children settle better in class and prepare them for learning.</p>
<p>4. Throw on Extra Veggies: Zesty Extras</p> 	<p>Resources:</p> <ul style="list-style-type: none"> • Deep Down Detectives Song • Classroom Rules Chant • The Big Question Box Song • The Bible Song • Let's Pray Song • ACTS Prayer Song 	<p>These are few extras that add zest to the curriculum. The Classroom Rules Song is especially helpful for reminding the children of expected classroom behavior in a fun way.</p>
<p>5. Spread on Condiments: Transitions</p> 	<p>Resources:</p> <ul style="list-style-type: none"> • The Classroom Song (4 verses) 	<p>Harnessing the transition points in your curriculum can make teaching much easier for your teachers and actually fun for your kids. The Deep Down Detectives curriculum uses music to structure and teach the children through every transition.</p>
<p>6. Choose Your Bread: Curriculum Presentation Features</p> 	<p>Resources:</p> <ul style="list-style-type: none"> • Big Question Box/Briefcase • Storyboard Flannelgraph Pictures or Story Scenes 	<p>These are resources that are used to present the curriculum to the children. They help keep the children focus and make the learning more visual and interactive.</p>
<p>7. Prepare It for Carry Out Take Home Resources</p> 	<p>Resources:</p> <ul style="list-style-type: none"> • Coloring Sheet/Take Home Sheet for each lesson • Take Home version of each story 	<p>Take home resources are a great way for parents to know what their children are learning and to provide them with a tool for further discussion.</p>

Common Customizations: Age Groups

Having considered these questions, put this information to work to build your version of the curriculum.

Here are some ways we have customized the curriculum or seen it customized by others:

CUSTOMIZE BY: Age Group	
2 year olds	<p>GENERAL OBSERVATIONS: You are doing well just to get these children to begin to sit as a group. Build up to this, as they get adjusted to a classroom setting. Set your expectations LOW! Helping the children learn how to be a group prepares them for learning more later and even more being able to join in the church service better. This, by itself, is a job well-done.</p> <p>NUMBER OF LESSONS OF A BIBLE TRUTH USED: All three lessons for sure! Repetition is great for these kids! But, if you go at this rate, you will not get very far through the 70 Bible Truths in a year. Consider using Hide 'n' Seek Kids instead.</p> <p>SUGGESTIONS FOR HOW TO USE THE CURRICULUM:</p> <p>Opening Activity Time:</p> <ul style="list-style-type: none"> • Free play time as they come to class • You can have unit music playing in the background • Use the Classroom Songs to begin to teach them about transitions <p>Opening Circle Time:</p> <ul style="list-style-type: none"> • Use the Big Question Box/Briefcase • Teach them the Big Question • Sing the Big Question Song (short, nursery rhyme version) • Teach them the Bible Truth • Tell them the Bible Verse (maybe sing the song) • Tell the Bible story, using the storyboard • Do not expect these children to be able to do the listening assignment. • End with the ACTS prayer or an even shorter prayer, if attention is lagging. <p>Response Activity Time:</p> <ul style="list-style-type: none"> • Dismiss to free play time. • You can have unit music playing in the background. • Offer the coloring sheet/take home sheet craft after they have played for a while. • You MIGHT be able to weave a few of the discussion questions into your conversations with the children as they play or do their coloring sheet... but don't count on it. It's just fine if they don't! They are only two years old! <p>Closing Circle Time:</p> <ul style="list-style-type: none"> • Use the Classroom Songs to gather them back together. • Ask them the Big Question and Answer, tell them the Bible Truth, and sing the short Big Question Song again. • End with the ACTS prayer or an even shorter prayer, if attention is lagging. <p>Dismissal:</p> <ul style="list-style-type: none"> • Give out the take home version of the Bible Story, the day you start a new Bible Truth. • Give out coloring sheet/take home sheet for the lesson.

Common Customizations: Age Groups

CUSTOMIZE BY: Age Group	
3 year olds	<p>GENERAL OBSERVATIONS: This age group can enjoy much of this curriculum.</p> <p>NUMBER OF LESSONS OF A BIBLE TRUTH USED: All three lessons for sure! Repetition is great for these kids! But, if you go at this rate, you will not get very far through the 70 Bible Truths in a year. Consider using Hide 'n' Seek Kids instead.</p> <p>HOW TO USE THE CURRICULUM: As written, except... the listening questions will be a new concept to this children of this age. This is the new skill you will be working on to give the children. It may take a while to get them used to holding on to a question or two as they listen. You might even want to remind them of the questions as you read the story. (This is another way we help these children prepare to gather with the congregation and be ready to learn from a sermon. And, be careful not to overwhelm them with too many discussion questions. Choose a few and repeat them when playing the games. Add in more as they master the answers to your initial ones.</p>
4-5 year olds OR 2-5 year olds as one class	<p>GENERAL OBSERVATIONS: 4-5 year olds: The concepts of the curriculum were especially created with this age group in mind.</p> <p>2-5 year olds as one class: You are combining children with fairly different developmental abilities. While one teacher is teaching, the other teacher may need to be quietly tending to the 2 year olds as their attention span fades.</p> <p>NUMBER OF LESSONS OF A BIBLE TRUTH USED: These children will do best with 2-3 lessons of the three included with each Bible Truth. We do two concepts per month of Sundays. That 2 lessons from Bible Truth, then 2 lessons from the next Bible Truth. Or, in months with five Sundays, you would choose to do 2 lessons from one Bible Truth and 3 lessons from the next. You will complete the curriculum in about 2 1/2 years at this rate.</p> <p>HOW TO USE THE CURRICULUM: As written. You can introduce the longer, full Big Question Songs, not just the short nursery songs with children.</p> <p>And, for those who have combined 2-5 year olds, having the children do the suggested actions that go with the full, Big Question Songs can be a great chance for the little 2-year-olds to get some wiggles out.</p>

Common Customizations: Age Groups

CUSTOMIZE BY: Age Group

pre-K & K

GENERAL OBSERVATIONS:

The concepts of the curriculum were especially created with this age group in mind.

NUMBER OF LESSONS OF A BIBLE TRUTH USED:

These children will do best with 2 lessons of the three included with each Bible Truth. We do two concepts per month of Sundays. That 2 lessons from Bible Truth, then 2 lessons from the next Bible Truth. Or, in months with five Sundays, you would choose to do 2 lessons from one Bible Truth and 3 lessons from the next. **You will complete the curriculum in about 2 1/2 years at this rate.**

HOW TO USE THE CURRICULUM:

As written. You can introduce the longer, full Big Question Songs, not just the short nursery songs with children.

K-2nd grade

GENERAL OBSERVATIONS:

The concepts of the curriculum can still very good for this age group, but you are bumping up against its outer limits. I would move on to Praise Factory Investigators, if I was using Deep Down Detectives with the preschoolers. However, if this curriculum is being introduced with this age group, it will be great for them.

NUMBER OF LESSONS OF A BIBLE TRUTH USED:

These older children will do best with 1 to 2 lessons of the three included with each Bible Truth. You will probably bore them if you repeat beyond this point.

HOW TO USE THE CURRICULUM:

Definitely introduce the longer, full Big Question Songs, not just the short nursery songs with this group.

I would eTher do:

two, full lessons per Bible Truth;

OR,

I would do one full lesson per Bible Truth, then use the Opening Activity time of the next session to review the previous session's concepts by playing the Bible Story game/ Bible Verse Review Game/singing the songs). I would then introduce the next Bible Truth concepts in Opening Circle Time.

Common Customizations: Teaching Situations

CUSTOMIZE BY: Teaching Situation	How to Structure the Curriculum
<p>Single Session One, 60-90 minute session on a lesson, in one day, once a week examples: Sunday School, Church Hour, Mid-week programs</p>	<p>As written. If you do not really have 60 minutes of actual teaching time, you will need to choose what not to use. Choose what you think is most important to have in your session, then continue to add in elements until you have filled up your time budget.</p>
<p>Double Session Two 60-90 minute sessions, on the same lesson, in one day, once a week examples: Sunday School PLUS Church Hour OR, Sunday Morning PLUS Sunday Evening OR, Sunday Morning PLUS Wednesday Evening</p>	<p><i>(This is how we use the curriculum here at CHBC)</i></p> <p>First session of the Double:</p> <ul style="list-style-type: none"> • Use Opening Activity • Opening Circle Time • And choose an activity • Fill in extra time with free play activities <p>snack and potty break</p> <p>Second session of the Double:</p> <ul style="list-style-type: none"> • Review Opening Circle Time • Choose another activity • Fill in extra time with free play activities
<p>Daycare/Schools Bible Class</p>	<p>Schools vary in how many days they teach Bible. Some will have a daily Bible class. Others, will have it only certain days.</p> <p>Here's a suggestion for one Bible Truth a week, 5 days a week Bible class for preschoolers:</p> <p>Typically, each session you will be:</p> <ul style="list-style-type: none"> • Reminding the children of the Big Question and Bible verse; • Telling them the Bible story (or asking them questions to review it); • Singing the songs; and, • Following up with a response activity. <p>There are three lessons in each Bible Truth, with a listening assignment for each lesson. each with a coloring page, and three games; plus, three extra crafts.</p> <ul style="list-style-type: none"> • That makes 12 activities, plus the three extra crafts. Plenty for a week of Bible classes for little preschoolers. • You could read the story on Monday, Wednesday and Friday, using a different listening activity each time. Use the coloring sheet corresponds to the listening activity on those days. • Then, the other two days of the week, use the games to review what they have learned. <p>With 16 units of 67 Bible truths, this gives you about two academic years of curriculum.</p>
<p>Camps, VBS and Short-term Missions Trips</p>	<p>Since camps, VBS and mission trips usually involve both preschoolers and elementary school children, you will do best use two or three of the Praise Factory family of curriculum to meet everyone's needs. At the end of this introduction section, we provide suggested schedules for these ministry situations. We also have included how the Bible Truths across all three curriculums line up so you can coordinate the truths you are teaching across all of the age groups/curriculums.</p>

Maiden Voyage: Testing Out the Curriculum

Making a Test Run

At last it's time to try out the curriculum on your kids. As mentioned before, our favorite way to try out a new curriculum is with a smaller group of children (of the more-likely-to-be-well-behaved variety), when there is an opportunity to do so. This gives the curriculum its best test-run. Ideally, you want to give any curriculum a few sessions trial period. New curriculum is new curriculum. Teachers will be getting used to it as will the kids.

You may choose to dive in the deep end and introduce the whole curriculum to the children at once. As you introduce the curriculum to your children, also remember that everything will be new to them at first. New ideas and structures use up a lot more attention and energy than when they are familiar and routine...and it takes time for them to become routine. Be patient! Expect this!

Or, you may take the gradual approach, deciding on lesson elements to introduce gradually, then adding more in as you go. Think about the routine the children are used to in your classroom already. What works? What doesn't work? Slot Deep Down Detectives resources into the parts of your current framework that work best with your children, then gradually build from there.

For example, you might want to start with just the Bible story and Bible verse the first lesson, adding other elements the second lesson, and so on. Also, realize that the children will be doing a lot more watching and a lot less direct participation at first as they are learning the routine.

Give yourself and the children a few lessons to settle into the routine before deciding what is the right amount of activities to include each week. As the children get used to the lesson routine, you will find the children have more attention and energy to devote to the learning activities.

Evaluate and Adjust It

As you test-run the curriculum, you will probably want to evaluate and make changes. Reflect on how the teaching session goes, after each of your test runs and make any necessary changes. As you get closer to a good fit, add in more conditions like the typical classroom--such as your crazier kids, etc.. See how the curriculum works with these new elements. Make more changes until you feel good about your fit.

The Real Launch: Implementing the Curriculum in Your Situation

Sign Post It	Once you have figured out what works best for your children and those teaching the curriculum, put sign posts in place in the classroom. If you found that certain activities work better in a certain part of the room (such as games or craft time), put up a sign on the wall near that area indicating that. Or, put down a rug where you want to have Circle Time.
Choose and Train Your Load-Bearers	<p>If the curriculum follows a set time schedule, display the schedule on the wall in large print so a teacher can with just a glance know what he/she should be doing.</p> <p>Signpost where you store your curriculum resources (games, curriculum, music, craft supplies, etc), too, so that even the newest teacher can easily find what he/she needs.</p> <p>Once you feel that you have adjusted the curriculum to a good fit for teacher and children, begin to train others in how to teach it, too. Ideally, this starts as a mentoring experience between you and another teacher (preferably two). You are looking for people who are willing to learn the curriculum inside-out until they can teach it well themselves and can later train others in it, too. I call these teachers, "load-bearers," because they will share the weight of implementing the new curriculum.</p> <p>First, have your load-bearers come observe you as you teach the curriculum. Have them read the introductory materials and the curriculum lesson plan before they observe. After class, de-brief with them about the session. Have them continue to come for a number of session, gradually handing over the teaching responsibilities until they are comfortable and confident.</p>
Bring the Parents Up to Speed	Make sure to include parents in your launch! Communicate with them about the change in curriculum that is happening. Hold a meeting. Send out an email. Hand out the Deep Down Detectives flyer (pgs. 7-8, Core Curriculum books). Ask them to parents. Invite their feedback. Make them your partners, after all, it is them and their kids you hope to help.
Add Others	With your load-bearers in place and confident in the curriculum, you can now begin to look for more potential teachers to be trained. The load-bearers will then follow the same steps as you took with them: having them observe, then gradually take teaching responsibilities, de-briefing after each session. Continue until they are confident.
Want to See More?	<p>Three times a year (the third Saturday/Sunday of March, May and September), we hold a free lunch, learn-and-look workshop and observation time here at Capitol Hill Baptist Church in Washington, D.C.</p> <p>On Saturday, we gather for lunch and talk philosophy; child protection policy; encouraging parents; recruiting teachers; dealing with discipline issues; etc; and, of course, curriculum. After finishing up our group session, we are happy to talk to individual churches about their particular situations.</p> <p>Then on Sunday, we offer an opportunity to see Deep Down Detectives and the other Praise Factory curriculum in action in our classes. This can be a great way to help others understand and get excited about the curriculum.</p> <p>The registration form for these workshops can be found on the Praise Factory website.</p>

Protect Your Investment: Tips on Storing the Curriculum for Future Use

This is a curriculum that keeps on giving year after year. Everything is re-used. If you do a good job storing the curriculum, it will serve your church well and at little cost for many years.

Here are two ideas to help you:

Idea #1: If you are teaching only a small group of children:



Then, store all of these resources together in a magazine file



Protect Your Investment: Tips on Storing the Curriculum for Future Use

Idea #2: If you are teaching a large group of children (like we do at CHBC), you may want to have a separate envelope for each resource type.

Copies of
Unit Lesson Plan,
and Story
with Listening
Assignments

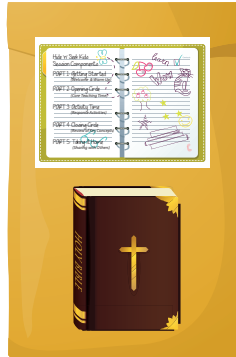

CDs,
Song Track Lists,
Lyrics &
Sheet Music

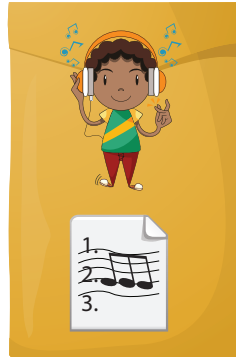

Bible Story
storyboard
Pictures,
Pictures Key and
Placement Guide



Discussion Sheet



Visual aids,
(except for Bible
Storyboard Pics)

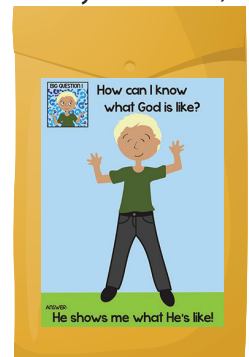

Craft/Take Home
Sheet 1



Craft/Take Home
Sheet 2



Craft/Take Home
Sheet 3



Extra Craft 1



Extra Craft 2



Extra Craft 3



**Then, store all of these
resources together in a
magazine file**



Protect Your Investment: Tips on Storing the Curriculum for Future Use

Store your games in separate ziploc bags and put them in bins.:

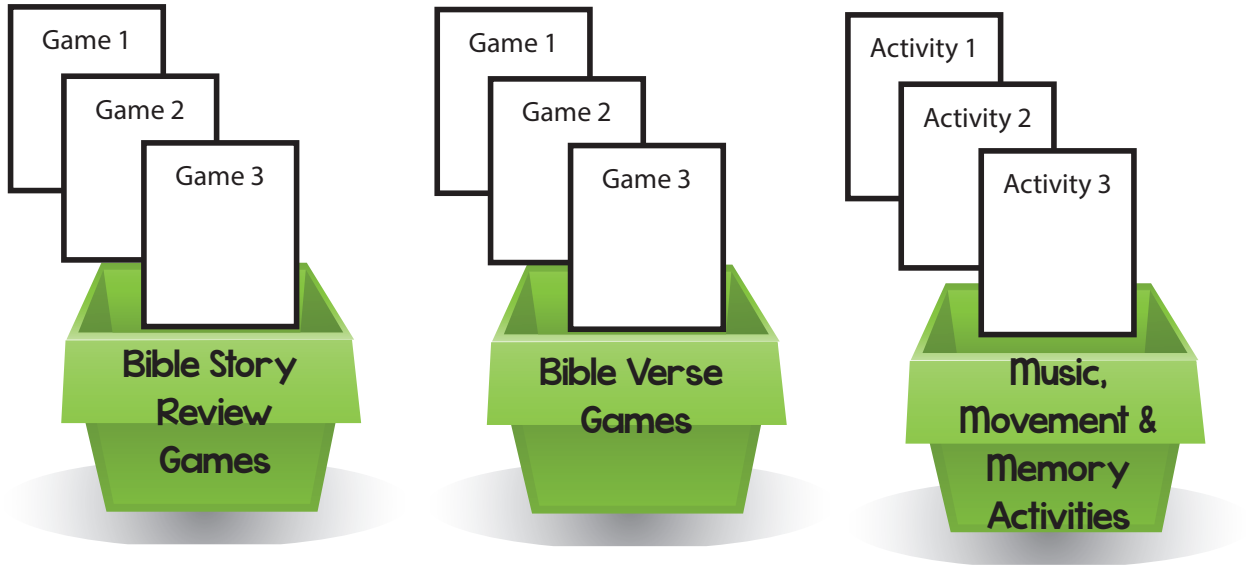

Master Supplies List for All Deep Down Detectives Games

Deep Down Detectives uses many games. The good news is, they are simply made and they are re-used throughout the whole curriculum. Make sure you save the games you make and it will save you a lot of time later.

This is the full list of the games and the supplies needed in the Deep Down Detectives Curriculum. While you only need to make whatever games you choose to use with each lesson, **I strongly recommend that you make all the games before you start using the curriculum.** Get the prep work over with at the beginning and coast your way through years of enjoyment! Store them in ziploc bags or baskets and pull them out when needed. So simple!

THIS LIST IS ALSO INCLUDED IN APPENDIX B: GAMES

Bible Verse Games

Lily Pad Jump

- Cube-shaped cardboard box,
- paper,
- glue,
- marker

Animal Cube

- Cube-shaped cardboard box,
- paper,
- glue,
- marker

Simon Says How

- Cube-shaped Cardboard box
- Paper, glue, and a marker

Bean Bag Catch

- 1 bean bag per every 2 children (or every child)
- NOTE: Can also fill socks with beans and tie open end to make beanbags.

Slap, Clap and Stack

- 10 or 12 Blocks or other stackable objects

Freeze 'n' Say

- Music and CD/Tape player

Fill 'er Up

- 1 bean bag per child
- NOTE: Can also fill socks with beans and tie open end to make beanbags.
- Cardboard box or laundry basket
- Carpet squares, 1 per child

Loud and Soft, Big and Little

- none

Bible Verse Games

Roll 'n' Toss

- Cube-shaped Cardboard box
- Paper, glue, and a marker
- 1 bouncy ball per 2 children

Duck, Duck, Goose

- none

Deep Down Detective Mission Madness Practice

- Detective Gear, such as a trench coat, sunglasses, and a hat

Block Clapping

- 2 wooden blocks per child, preferably about 3"x 2", as found in many children's block sets

Meet, Greet, and Keep It Up

- 16 oz cups, 1 per child (with some extras)
- 2 pieces of rope as long as a line of children
- Masking tape

Master Supplies List for All Deep Down Detectives Games, continued

Music, Movement & Memory

Thumping Drums

- 1 Oatmeal container/coffee can with lid per drum
- Tape
- Popcorn, rice, beans, etc.
- Wooden spoons, dowels, unsharpened pencils, if desired, for mallets

Say, Spring Up and Shout

- Bean bags, one per child

Freeze Frame

- Some kind of fun hat or clothing for the leader to wear

Egg Shakers

- Empty Easter eggs
- Rice, beans, buttons, pennies, popcorn, beads, small nails or bolts, etc.
- Glue and glue gun OR strong packing tape

Jingle Bell Hands

- 1 6" piece of sturdy string
- 4 or 5 jingle bells, available in most craft shops

Sing, Dance, and Fall Down

- Optional: Bean bags, one per child

Big Voice, Little Voice

- none

Bottle Shakers

- 1 empty 16 oz. soda bottle per shaker
- Rice, beans, buttons, pennies, popcorn, beads, small nails or bolts, etc.
- Glue and glue gun OR strong packing tape

March 'n' Say

- Optional: A fun hat for the leader of the march, or for everyone in the march

Clap, Tap and Say

- none

Lullabies, Bells and Lions

- Bell

Music, Movement & Memory

Musical Squares

- Carpet Squares, enough for all of the children (or chairs)

Block Clappers

- 2 wooden blocks per child, preferably about 3"x 2", as found in many children's block sets

Master Supplies List for All Deep Down Detectives Games, continued

Story Review Games

Going Fishing

- One long wooden dowel, yardstick, etc. per fishing pole
- Yarn
- Paper clip per fishing pole
- Rope
- Two chairs
- Blanket
- Box/bucket/container
- Bucket

Pony Express

- Small manila envelopes, one per flannel graph figure
- Kid's small backpack or a tote bag with a strap
- Basket
- Cowboy hat
- Stick horse or a broom

Fix Up the Mix Up

- None

Can You Remember?

- Index cards

Deep Down Detectives Clue Hunt

- Variety of interesting items that have one or more places to hide a storyboard picture
- Detective Hat
- 4 False Clues (included on the next page)
- CD Player and Deep Down Detectives Theme Song

Clothespin Line Up and Drop

- Rope
- Clothespins, the hinged type
- Shoe box
- Tape

Who's in the Basket?

- Blanket
- Basket

Run to the Grocery Store

- Grocery bag or kid's grocery cart
- Empty food cartons

Story Review Games

Treasure Hunt

- 10 small lidded plastic containers or boxes (like from a jewelry store) or wooden, hinged boxes from a craft store
- Various decorating supplies, such as fake craft jewels, glitter, glitter glue, foil paper, gold spray paint
- glue

Take Me Through the Tunnel

- Chairs or Table
- Sheet or blanket
- Box

Missing in Action

- None

Who's Inside?

- 10 different containers with lids

Look Who's Coming Down the Tracks

- Two shoe boxes
- 6' or so of rope
- Optional: Engineer's hat

VBS, Camps and other Programs

Programs like camps, VBS and short-term missions Children's Ministry usually involve such a wide, age-range of children that it's best to use two or three curriculums, instead of just one, to meet everyone's learning level. This is easy to do with the Praise Factory family of curriculum, since you are using the same, sixteen Big Question Units in all three curriculums.

There are so many ways to do these programs. Here are the most common ones I've heard of:

- One, half day
- One, full day
- One evening
- Friday Night-Saturday
- Five, half days
- Five, full days
- Five evenings in a row
- Five one-day evenings (such as five Wednesday nights in a row)
- Two, five-day weeks in a row

Although these programs take place at many different times, they typically run one of three, standard lengths of time:

- 1 1/2 hour programs
- 2 1/2 hour programs
- 6 hour programs

Here are session suggestions for each of these three lengths of programs:

NOTE: I have put some place holder times in schedules. You change them to your actual times.

1 1/2 Hour Multi- Age Programs

1 1/2 Hour Program (for 2 year olds):

- 9:00 Free Play/Activity Centers
- 9:15 Opening Circle Time (Singing, Big Question, Bible Verse and Bible Story)
- 9:30 Free Play/Activity Centers
- 9:45 Activities: Game, Craft and/or Music
- 10:20 Closing Circle Time
- 10:30 Dismissal

1 1/2 Hour Program (for ages 3-5):

Hide 'n' Seek Kids or Deep Down Detectives Session, as written

1 1/2 Hour Program (for elementary age kids):

Praise Factory Investigators Session, as written

VBS, Camps and other Programs: 1 1/2 Hour Schedule

1 1/2 Hour Program (for 2 year olds): (Hide 'n' Seek Kids or Deep Down Detectives)

- (9:15 – Early Arriver Activity – a few puzzles or paper and crayons on a table)
- 9:30 – Activity Centers
- 9:40 – Clean Up Toys
- 9:45 – Opening Circle Time (Add actions to songs to make this time more active)
- 10:05 – Craft Time (Use one of the Extra Crafts)
- 10:15 – Play with Toys /Check Diapers/Potty Break
- 10:25 – Clean Up Toys
- 10:30 – Memory Verse Time: Music, Movement & Memory; Bible Verse Review Game
- 10:40 – Snack Time
- 10:50 – Closing Time/Take Home Sheet/Coloring Time (Ask them the Closing Time questions as they are coloring at the tables)
- 11:00 – Parents come

1 1/2 Hour Program (for 3-preK 5 year olds): (Hide 'n' Seek Kids or Deep Down Detectives)

- (9:15 – Early Arriver Activity – a few puzzles or paper and crayons on a table)
- 9:30 – Activity Centers
- 9:40 – Clean Up Toys
- 9:45 – Opening Circle Time (Add actions to songs to make this time more active)
- 10:05 – Craft Time (Use one of the Extra Crafts)
- 10:15 – Play with Toys /Check Diapers/Potty Break
- 10:25 – Clean Up Toys
- 10:30 – Memory Verse Time: Music, Movement & Memory; Bible Verse Review Game
- 10:40 – Snack Time
- 10:50 – Closing Time/Take Home Sheet/Coloring Time (Ask them the Closing Time questions as they are coloring at the tables)
- 11:00 – Parents come

1 1/2 Hour Program--elementary school (Praise Factory Investigators)

- 9:00 Opening Large Group Time: Welcome, Singing
- 9:15 Opening Large Group Time: Big Question, Bible Truth, Bible Verse and Bible Story
- 9:45 Small Group Activities (Discussion and Games/Music/Craft Activities) If desired, each small group can prepare their activity for Small Group Presentations in Closing Large Group.
- 10:15 Closing Large Group Time: Small Group Presentations and/or Singing
- 10:30 Dismissal

VBS, Camps and other Programs: 2 1/2 Hour Schedule

2 1/2 Hour Program (for 2 year olds): (Hide 'n' Seek Kids or Deep Down Detectives)

- (8:45 Early Arriver Activity – a few puzzles or paper and crayons on a table)
- 9:00 Activity Centers (first set)
- 9:10 Clean Up Toys
- 9:15 Opening Circle Time (Add actions to songs to make this time more active)
- 9:25 Activity Centers (first set)
- 9:35 Craft Time (Use one of the Extra Crafts)
- 9:45 Play with Toys /Check Diapers/Potty Break 2
- 9:55 Clean Up Toys
- 10:00 Snack Time
- 10:10 Memory Verse Time: Music, Movement & Memory; Bible Verse Review Game
- 10:20 Activity Centers (second set)
- 10:30 Clean Up Toys
- 10:45 Craft Time (one of the extra crafts)
- 10:55 Play with Toys /Check Diapers/Potty Break 2
- 11:00 Clean up Toys
- 11:05 Active Indoor/Outdoor Play
- 11:25 Closing Time Circle Time
- 11: 15 Coloring Time/Take Home Sheet
- 11:30 Parents come

2 1/2 Hour Program (for 3-preK 5 year olds): (Hide 'n' Seek Kids or Deep Down Detectives)

- (8:45 Early Arriver Activity – a few puzzles or paper and crayons on a table)
- 9:00 Activity Centers (first set)
- 9:15 Clean Up Toys
- 9:20 Opening Circle Time (Add actions to songs to make this time more active)
- 9:40 Craft Time (Use one of the Extra Crafts)
- 9:55 Activity Centers (first set)
- 10:10 Clean Up Toys
- 10:15 Potty Break/Wash Hands
- 10:25 Snack Time
- 10:35 Active Indoor/Outdoor Play OR Activity Centers (second set)
- 10:50 Clean Up Toys
- 10:55 Memory Verse Time: Music, Movement & Memory; Bible Verse Review Game
- 11:10 Closing Time Circle Time
- 11:20 Coloring Time/Take Home Sheet
- 11:30 Parents come

2 1/2 Hour Program--elementary school (Praise Factory Investigators)

- 9:00 Opening Large Group Time: Welcome, Singing
- 9:15 Opening Large Group Time: Big Question, Bible Truth, Bible Verse and Bible Story
- 9:45 Small Group Activity 1: Discussion and Craft Activity
- 10:15 Active Outdoor/Indoor Play
- 10:30 Snack (Story-related snack) ACTS and Discussion Time (related to activity they are about to do 10:45 Small Group Activity 2: (Prepare this one for presentation to the rest of the children during Closing Large Group Time, if desired)
- 11:15: Closing Large Group Time: Small Group Presentations and/or Singing
- 11:30 Dismissal

VBS, Camps and other Programs: 6 Hour Schedule

6 Hour (Full Day) Program (for 3-preK 5 year olds): (Hide 'n' Seek Kids or Deep Down Detectives)

Use one Bible Truth and Bible story for the whole day's session. Afternoon provides an opportunity for reinforcement.

Morning Schedule

- 8:45 Early Arriver Activity – a few puzzles or paper and crayons on a table)
- 9:00 Activity Centers (first set)
- 9:15 Clean Up Toys
- 9:20 Opening Circle Time (Add actions to songs to make this time more active)
- 9:50 Active Indoor/Outdoor Play (Playground or organized games)
- 10:30 Potty Break/Wash Hands/Snack Time
- 10:45 Music, Movement & Memory Game and Singing
- 11:00 Craft Time (Use one of the Extra Crafts)
- 11:30 Activity Centers (second set)
- 12:00 - 1:00 Lunch and Play Time/Rest Time

Afternoon Schedule

- 1:00 Bible Story Review & Bible Verse Review (repeat story and storyboard or use games to review)
- 1:20 Craft Time (Use one of the take home sheet coloring activities of the Extra Crafts)
- 1:40 Activity Centers (second set)
- 2:00 Snack and Potty Break
- 2:30 Closing Circle Time Review/Singing
- 2:40 Free play, games, possibility outdoors
- 3:00 Dismissal

6 Hour (Full Day) Program--elementary school (Praise Factory Investigators)

Use two stories from same Bible Truth: one in the morning, one in the afternoon.

- 8:45 Greet children and parents as they arrive
- 9:00 Small Group Time: Introduce Big Question, Bible Truth, Bible Verse, etc.
- 9:15 Large Group Singing and Bible Story
- 9:45 Small Group Activity 1: Bible Truth Game
- 10:15 Small Group Activity 2: Craft
- 10:45 Snack and ACTS Prayer Time
- 11:00 Outdoor Fun - Active Game 1
- 12:00 Lunch and Free Play Time

Afternoon Schedule

- 1:00 Large Group Singing and Second Story (Other Bible Story or Story of the Saints)
- 1:30 Small Group Activity 1: Presentation Activity (Choose a different activity for each small group to work on during this time. They will present it to the rest of the children at the end of the session, if desired.)
- 2:15 Snack Time
- 2:30 Closing Large Group Time: Small Group Presentations and/or Singing
- 3:00 Dismissal

VBS, Camps and other Programs: Choosing Curriculum

You've figured out how many sessions your program will run and how long each session will last. Next, you need to figure out which curriculum you want to use. We suggest using Hide 'n' Seek Kids and/or Deep Down Detectives with your pre-schoolers and Praise Factory Investigators for your elementary school kids.

Find a unit you want to become the theme of your VBS. Choose the Bible Truths you want to teach. The charts of the following pages should help you see how the Bible Truths match up in the three curriculums. You've got tons of resources within each concept to fill up your schedule.

Here's a reminder of what you have in each:

Each Hide 'n' Seek Kids unit has:

- There is just one Bible Story and one Bible verse per unit.
 - There are 5 lessons of curriculum in each unit.
 - There is tons of music.
 - The activities in each of the 5 lessons include:
 - 1 Bible Story Review Game
 - 1 Bible Verse Game
 - 1 Music, Movement & Memory Activity (especially good for Bible Memory)
 - 1 Coloring Sheet/Take Home SheetThere are also 3 extra crafts
-

Each Deep Down Detective unit has:

- There are multiple Bible truths within each unit.
 - There are three lessons of curriculum, per Bible Truth, within each unit.
 - There is one Bible story for each Bible Truth.
 - There are 3 lessons of curriculum for each Bible Truth.
 - There is tons of music
 - The activities in each of the 3 lessons include:
 - 1 Bible Story Review Game
 - 1 Bible Verse Game
 - 1 Music, Movement & Memory Activity (especially good for Bible Memory)
 - 1 Coloring Sheet/Take Home SheetThere are also 3 extra crafts
-

Each Praise Factory Investigators unit has:

- Multiple Bible truths within it.
- There are three lessons of curriculum, per Bible Truth
- There are 3 stories for each Bible Truth: 1 Old Testament, 1 New Testament, and one Church History/missions.
- There are 3 lessons of curriculum for each Bible Truth--one for each of the three stories.
- There is tons of music.
- Each of the 3 lessons includes:
 - 1 Bible Story Review Game with Discussion Questions
 - 1 Bible Verse Game with Discussion Questions
 - 1 Bible Truth Game with Discussion Questions
 - 1 Craft with Discussion Questions
 - 1 Bible Verse Game with Discussion Questions
 - 1 Bible Verse Song with Discussion Questions, Sign Language and Song Game
 - 1 Hymn with Discussion Questions, Sign Language and Song Game
 - 1 Story-related Snack
 - 1 Take home sheet with the key concepts, the story and some discussion questions

Bible Truths that Match Up Across the Curriculums		
Hide 'n' Seek Kids	Deep Down Detectives	Praise Factory Investigators
Unit 1: The God Who Reveals Himself Q: How Can I Know What God Is Like? A: He Shows Me What He's Like!	1. By the Heart He Gave Me to Know and Love Him	1. God Made Our Hearts to Know and Love Him
	2. In Everything I See All Around Me	2. God's Creations Tell Us about Him
	<i>included in DDD Unit 1 Bible Truth 3, below</i>	(3. God Spoke to His People through Prophets Long Ago)
	3. In the Bible, the Perfect Word of God	4. God Speaks through His Word, the Bible
Unit 2: God's Wonderful Word, the Bible Q: What's So Special about the Bible? A: It Alone Is God's Word!	4. Through His Very Own Son, Jesus Christ	5. God Reveals Himself Most Completely through His Son, Jesus
	1. God Made Sure It Was Written Down Just Right	1. God Inspired Many People to Write Down His Word Perfectly
	2. It Tells Us about God and His Plans	2. God's Word Tells God's Way and Plans for His People, Past, Present and Future
	3. God Uses It to Save His People	3. God Uses His Word to Save His People
Unit 3: The Good News of God, the Gospel Q: What Is the Gospel? A: Salvation through Faith in Jesus Christ!	4. God Uses It to Change His People	4. God Uses His Word to Change His People
	1. God Made Us and We Should Obey Him	1. God Is the Good Creator and King of the World
	2. We Have All Disobeyed God and Deserve His Punishment	2. All Have Rejected God and Deserve His Eternal Punishment
	3. God Sent Jesus to Pay for God's People's Sins	3. God Sent Jesus to Bear the Punishment for Sin
Unit 4: The God Like None Other Q: Can Anybody Tell Me What the LORD Is Like? A: He's Not Like Anyone Else!	4. God Saves All Who Repent of Their Sins and Trust in Jesus as Their Savior	4. God Saves Those Who Repent and Trust in Jesus
	1. He Is a Glorious Spirit	1. The LORD is a Glorious Spirit
	2. He Is the One, True God	2. The LORD is the Only True God
	3. He Is God the Father, Son and Holy Spirit: One God, But Three Persons	3. The LORD Is God the Father, Son and Holy Spirit: One God, But Three Persons
	4. He Is Everywhere, All the Time	4. The LORD Is Everywhere, All the Time
	5. He Knows Everything There Is to Know	5. The LORD Knows Everything There Is to Know
	6. He Is Perfectly Holy, Purely Good	6. The LORD is Holy
	7. He Can Do Anything He Wants to Do	7. The LORD is Omnipotent
	8. He Is Always Faithful, Through and Through	8. The LORD is Faithful
<i>included in DDD Unit 4 Bible Truth 2, above</i>	9. The LORD's Names Tell Us About Him	
Unit 5: God, the Good Creator Q: Can You Tell Me What God Made? A: God Made All Things Good!	1. He Made Everything Good in Heaven and Earth	1. God Created All Things Good in the Beginning
	2. God Made People in a Special Way	2. God Created People Good in the Beginning
	<i>included in DDD Unit 5 Bible Truth 1, above</i>	3. God Created the World to Praise and Glorify Him
	<i>included in DDD Unit 5 Bible Truth 1, above</i>	4. God's Plans For His Creation Are Good and Unfailing
Unit 6: God, the Just and Merciful Q: How Did Bad Things Come into God's Good World? A: Bad Things Came Through Sin!	1. When Adam and Eve Chose to Disobey God	1. Angels and People Rebelled against God in the Beginning
	<i>included in DDD Unit 6 Bible Truth 1, above</i>	2. God Treated the First Sinners with Justice and Mercy
	2. When It Spread to the Whole World	3. All People Are Born Sinful, All People Need God's Mercy
Unit 7: The Law-Giving God Q: What Are God's Laws Like? A: God's Laws Are Perfect!	1. They are Written in the Bible, God's Word	1. God's Laws Are Written in the Bible
	<i>included in DDD Unit 7 Bible Truth 2, below</i>	2. God Created Us Perfect Law Keepers, But We Are All Lawbreakers
	<i>included in DDD Unit 7 Bible Truth 2, below</i>	3. God Gave Us His Laws to Convict Us of Our Sin that We Might Be Saved
	2. They Show Us that We Need God to Save Us	4. Jesus Kept God's Law Perfectly to Save God's People by His Grace
	3. They Tell Us How to Love God and Others	5. The Heart of God's Law is Love

Bible Truths that Match Up Across the Curriculums

Hide 'n' Seek Kids	Deep Down Detectives	Praise Factory Investigators
Unit 8: The God Who Loves Q: What Is God's Love for His People Like? A: It's More than They Could Ever Deserve!	<i>included in DDD Unit 8, Bible Truth 1, below</i>	1. God Blesses All People with Many Good Gifts
	<i>included in DDD Unit 8, Bible Truth 4, below</i>	2. God Loved His People Before They Loved Him
	1. He Gave His Son, Jesus, to Save Them	3. God Showed the Depths of His Love by Giving His Son to Save His People
	2. He Always Takes Care of Them	4. God Loves His People by Caring for Their Needs
	3. He Uses Their Sadnesses for Good	5. God Uses Everything in His People's Lives for Their Good and His Glory
	4. He Will Never Stop Loving His People	6. God Will Never Stop Loving His People
Unit 9: Jesus Christ, Immanuel, God with Us Q: What Did Jesus Come to Do? A: Jesus Came to Bring Us to God!	1. He Left His Home in Heaven to Save Us	1. Jesus, the Servant King
	2. He Never, Ever Disobeyed God	2. Jesus, the Obedient Son
	3. He Taught about God and Did Amazing Things	3. Jesus, the Amazing Teacher
	<i>included in DDD Unit Bible Truth 3, above</i>	4. Jesus, the Ruler of All Creation
	<i>included in DDD Unit 9, Bible Truth 5, above</i>	5. Jesus, the Lord over Life and Death
	<i>included in DDD Unit 9, Bible Truth 4, below</i>	6. Jesus, the Forgiver of Sins
	<i>included in DDD Unit 9, Bible Truth 2, above</i>	7. Jesus, the Christ, the Son of the Living God
	<i>included in DDD Unit 9, Bible Truth 1</i>	8. Jesus, the Glory of God
	4. He Died on the Cross for God's People's Sins	9. Jesus, the Ransom for Sinners
	5. He Rose from the Dead	10. Jesus, the Conqueror of Death
	<i>included in DDD Unit 9, Bible Truth 5, above</i>	11. Jesus, the Firstborn of the Resurrection
	6. He Went Up to Rule in Heaven	12. Jesus, the Reigning Son in Heaven
Unit 10: The Holy Spirit: The Indwelling God Q: What Does the Holy Spirit Do in God's People? A: He Changes Their Hearts!	1. The Holy Spirit Lives in God's People	1. The Holy Spirit Lives in God's People
	2. The Holy Spirit Gives God's People Courage	2. The Holy Spirit Gives God's People Courage
	3. The Holy Spirit Gives God's People Wisdom	3. The Holy Spirit Gives God's People Wisdom
	4. The Holy Spirit Builds God's Church	4. The Holy Spirit Builds God's Church
Unit 11: The God Who Saves Q: How Can We Be Saved? A: It Is God's Free Gift!	1. When We Tell God Our Sins and Turn Away from Them	1. God Saves Sinners Who Confess Their Sins
	<i>included in DDD Unit 11, Bible Truth 2, below</i>	2. Jesus Is the Only Way to Be Saved
	2. When We Trust in Jesus as Our Own Savior	3. We Must Trust Jesus as Our Savior
3. When the Holy Spirit Works in Our Hearts	4. The Holy Spirit Changes Our Hearts so We Can Be Saved	
Unit 12: God's People Live for Him Q: How Should God's People Live? A: They Should Live Like Jesus!	1. By Asking God for His Help	1. God's People Grow to Be More Like Jesus
	2. By Loving Him Most of All	2. God's People Love Him with All Themselves
	3. By Loving Other People As God Has Loved Them	3. God's People Love Others
	4. By Trusting God and Being Happy With What He Wants	4. God's People Trust Him
	<i>included in DDD Unit 12 Bible Truth 8, below</i>	5. God's People Are Good Stewards of His Gifts
	<i>included in DDD Unit 12 Bible Truth 5, below</i>	6. God's People Obey Him
	<i>included in DDD Unit 12 Bible Truth 5, below</i>	7. God's People Do Good Works God Has Prepared for Them
	5. By Learning God's Word and Obeying It	8. God's People Read His Word, the Bible
	<i>included in DDD Unit 12 Bible Truth 2, above</i>	9. God's People Think about Him
	6. By Saying "No" to Disobeying God	10. God's People Say "No" to Temptation
	7. By Telling the Good News of Jesus	11. God's People Tell Others about Him
	<i>included in DDD Unit 12 Bible Truth 4, above</i>	12. God's People Suffer According to His Plan
	<i>included in DDD Unit 12 Bible Truth 4, above</i>	13. God's People Know Heaven Is Their Home
	8. By Making Much of God	14. God's People Delight in His Glory

Bible Truths that Match Up Across the Curriculums		
Hide 'n' Seek Kids	Deep Down Detectives	Praise Factory Investigators
Unit 13: The Sustaining God Q: Why Do God's People Keep Believing in Him? A: It Is God's Sustaining Grace!	1. God, Alone, Sustains God's People	1. God, Alone, Sustains God's People
	2. God the Father Promises to Help His People	2. God the Father Promises to Help His People
	3. Jesus Provides God's People with Everything They Need	3. Jesus Provides God's People with Everything They Need
	4. The Holy Spirit Works in God's People	4. The Holy Spirit Works in God's People
	5. The Word of God Grows God's People	5. The Word of God Grows God's People
	6. God Uses His People to Strengthen and Comfort Each Other	6. God Uses His People to Strengthen and Comfort Each Other
Unit 14: The God Who Delights in Our Prayers Q: How Does God Want Us to Pray? A: Every Night and Day!	1. God Wants Us to Praise Him	1. God Delights in Our Adoration of Him
	2. God Wants Us to Confess Our Sins	2. God Delights in Our Humble Confession of Sin
	3. God Wants Us to Thank Him	3. God Delights in Our Thanksgiving to Him
	4. God Wants Us to Ask Him to Do Great Things	4. God Delights in Our Supplications to Him
	<i>included in DDD Unit 14 Bible Truth 4, above</i>	5. God Always Answers Prayers
	<i>included in DDD Unit 14 Bible Truth 4, above</i>	6. Jesus Is Why God Answers God's People's Prayers
Unit 15: God's People Gather Together Q: Why Do God's People Go to Church? A: To Worship God and Love One Another!	1. By Praising God for Jesus' Win over Death	1. God's People Gather Together for a Special, Weekly Worship Day
	<i>included in DDD Unit 15 Bible Truth 2, below</i>	2. God's People Are Led by Godly Leaders
	2. By Learning from God's Word, the Bible	3. God's People Gather to Hear God's Word
	<i>included in DDD Unit 15 Bible Truth 3, below</i>	4. God's People Are Called the Body of Christ
	3. By Caring for Each Other's Needs	5. God's People Love One Another with a Covenant Love
	<i>included in DDD Unit 15 Bible Truth 3, above</i>	6. God's People Gather to Give
	4. By Telling What God Has Done and Praying	7. God's People Gather for Fellowship
	<i>included in DDD Unit 15 Bible Truth 4, above</i>	8. God's People Invite Others to Gather with Them
	<i>included in DDD Unit 15 Bible Truth 4, above</i>	9. God's People Gather to Pray
	5. By Baptizing People Who Trust in and Live for Jesus	10. God's People Proclaim Their New Life in Christ through Baptism
	6. By Remembering Jesus Died to Save Them	11. God's People Celebrate Christ's Redeeming Sacrifice for Them
Unit 16: Jesus, the Returning King Q: What Will Happen When Jesus Comes Back? A: God Will Make Everything New!	1. Jesus Will Judge All People Fairly	1. King Jesus Will Return to End the World
	<i>included in DDD Unit 16 Bible Truth 1, above</i>	2. King Jesus Will Return When God's Work on Earth is Done
	<i>included in DDD Unit 16 Bible Truth 1, above</i>	3. When King Jesus Returns, God's People Will Be Made Like Him
	<i>included in DDD Unit 16 Bible Truth 1, above</i>	4. King Jesus Will Return to Bring the Wicked to Just and Final Punishment
	<i>included in DDD Unit 16 Bible Truth 1, above</i>	5. King Jesus Will Return to Judge God's People, Too
	<i>included in DDD Unit 16 Bible Truth 2, below</i>	6. King Jesus Will Be United with His Bride, God's People, Forever
	2. God's People Will Live Happily with God Forever	7. King Jesus Will Reign Forever

DEEP DOWN DETECTIVES

**Curriculum Resources
for Unit 11, Bible Truth 1:**



How Can We Be Saved?

It Is God's Free Gift...

**When We Tell God Our Sins and
Turn Away from Them!**

Session Prep (especially good for newbies!)

Pray!



Pray for the Holy Spirit to be at work in your and the children's hearts.

Review



If new to the curriculum, look at the **Getting Started with Deep Down Detectives section of the Core Curriculum book.** (p.5) It will be especially helpful to read through the Deep Down Detectives section of **The Praise Factory Tour: Extended Version Book.** This is a visual way to understand what goes on in the classroom. (A pdf of the book is found in the samples section on the website.)

Look through and Learn the Lesson



Read over **lesson plan.** Practice any **songs or action rhymes** you are using. Choose/make up motions to go with these. Choose less with younger children and more with older preschoolers. **Practice the lesson with the visual aids** and using the Big Question Box/Briefcase.

Read and Rehearse the Bible Story with Pictures



Read the Bible story from the Bible. Read the curriculum version. Practice telling it with the storyboard pictures. (If you have not previously laminated the story pictures, do that now.) Or, rehearse it from the Simple Story Scenes, if you are using those.

Let There Be Music



Download the music and listen to the songs. Choose which of the songs you will use with the children. If using live musicians, make sure they have the sheet music (Appendix A, Core Curriculum book).

Put the Props in Place



1. Prepare your Visual Aids. Put the Big Question, Unit Bible Truths, Bible Truth, Bible Verse, and Listening Assignment signs, as well as the Bible Story script in one side of the Bible folder.
2. Get out your storyboard. If using Simple Story Scenes, put these in your Bible Folder. Or, if using the individual storyboard figures, put all background pictures in place (they have a BG by the number). Put the rest of the storyboard pictures (these have a SB by the number) in order of use in the other side of the Bible folder.
3. Put the DDD Bible Folder as well as the Big Question sign in the Big Question Box/Briefcase and shut it. If your box/briefcase has locks and you want to use the unlocking the box as part of your session, lock it now....but make sure you have the key or know the code first.
4. Prepare the music CD or sheet music or mp3 device for use in your session.

Set Out Free Play Activities



Choose and set up free time activities you will use with the children. Choose a variety of different activities that will be enjoyed by different types of children. Rotate the activities you provide to keep them interesting and fresh to your children. (Suggestions in Appendix D, Core Curriculum books.)

Prepare Any Activities



Choose which (if any) of the Bible Truth games and crafts activities you want to use in the session. Bear in mind your time frame as well as the developmental abilities and attention span of your children as you decide which/how many to prepare. **Look over the Discussion Sheet** and choose a few questions you might use to spark discussion with the children as they do their activities (especially good for ages 3's+). Pray for God to give you opportunities to talk about these things with the children.

Let Them Take It with Them



Make copies of the craft/take home sheets, if you are not already using them as one of your activities. You may also want to make copies of the story (see take-home version of each story included in Appendix C with the other take home resources) to have for parents to use with their children at home. There's a link on each craft/take home sheet to the story, if you don't make hard copies.

Store It



After your session is over, collect the resources and store them for future use. This curriculum can be used over and over for years to come.

Unit 11: The God Who Saves

UNIT OVERVIEW

We all have disobeyed God. We have all lost the wonderful special closeness with God that He meant for us to have with Him. No matter how hard we try, we can't ever be good enough to win back special closeness with God. No, we can't save ourselves, but God can. That's why He sent Jesus: to save us as a free gift from Him. Anyone who turns away from their sins and trusts in Jesus as their Savior, will receive His forgiveness. They will become His people, who know Him in their hearts by His Holy Spirit. And one day, God will take them to live with Him forever. This is the free gift God offers to you and me. God is so kind to us!

In this unit we will learn three truths about this wonderful, free gift God offers us.

UNIT BIBLE VERSE: Romans 6:23, ESV

"For the wages of sin is death, but the free gift of God is eternal life in Christ Jesus our Lord."

BIG QUESTION UNDER INVESTIGATION: How Can We Be Saved?

ANSWER: It Is God's Free Gift!

OPTIONAL Big Question 11 INTRODUCTION LESSON (Use Hide 'n' Seek Kids Unit 11 Material)

Story: The Case of the Most Important Question *Acts 16*

Bible Verse: Romans 6:23



BIBLE TRUTH 1: When We Tell God Our Sins and Turn Away from Them (3 Lessons Available)

Story: The Case of the Changed Climber *Luke 19:1-9*

Bible Verse: 1 John 1:8-9

BIBLE TRUTH 2: When We Trust in Jesus as Our Own Savior (3 Lessons Available)

Story: The Case of the Amazed, Mad Man *Acts 8-9*

Bible Verse: Romans 10:9-10

BIBLE TRUTH 3: When the Holy Spirit Works in Our Hearts(3 Lessons Available)

Story: The Case of the Surprising, Second Birthday *John 3*

Bible Verse: Titus 3:5-7

Deep Down Detectives ESV Songs 11 Track Numbers

This is a listing of all songs mentioned in the unit curriculum. You may or may not choose to use all of the songs. They are listed in easy-reference order--NOT in the order used in the curriculum.

You may choose to simply burn a CD/load them onto an mp3 device in this order. Or, you may want to do what we do: choose the songs we want to use and create a play list of them in that order. Then, we burn a CD/upload the play list onto an mp3 device. A teacher only has to click forward to the next song, instead of hunting for the right track. The track number have been included as part of the title of each song, teachers will still have a reference to the track number listed in the curriculum (same as those listed below), even if you change the order on your customized play list.

SONGS USED EVERY UNIT OF THE CURRICULUM

- 1 The Classroom Song v.1
- 2 The Classroom Song v.2
- 3 The Classroom Song v.3
- 4 The Classroom Song v.4
- 5 Deep Down Detectives Theme Song
- 6 The Classroom Rules Song
- 7 Let's Pray Song
- 8 The Big Question Box Song
- 9 The Bible Chant Song
- 10 ACTS Prayer Song (Short Version)
- 11 ACTS Prayer Song (Full Version)

Why the Extra Songs?

Deep Down Detectives is a curriculum used by a wide age-span of kids. Sometimes one of the other songs is a better fit for your kids. Or, you may simply want to teach them more songs on the same Bible Truth. Use as many or as few as you want.

listen to or download songs for free at <https://praisefactory.org>: Deep Down Detectives Music page

UNIT 11: THE GOD WHO SAVES

- 12 Big Q & A 11 Song
- 13 Big Question 11 Song: How Can I Be Saved?
- 14 Big Question 11 Bible Verse Song: The Free Gift of God Is Eternal Life Romans 6:23, ESV
- 15 Big Question 11 Hymn: Grace Greater than All Our Sin, refrain
- 16 Big Question 11 Praise Song: Blessed Be the Name

How Can We Be Saved?

It Is God's Free Gift...

Bible Truth 1: When We Tell God Our Sins and Turn Away from Them

- 17 Bible Verse: If We Say We Have No Sin 1 John 1:8-9, ESV
- 18 Bible Verse: If We Say 1 John 1:8-9, ESV

Bible Truth 2: When We Trust in Jesus as Our Own Savior

- 19 Bible Verse: If You Confess with Your Mouth Romans 10:9-10, ESV
- 20 Extra Bible Verse: In My Father's House John 14:2-6, ESV

Bible Truth 3: When the Holy Spirit Works in Our Hearts

- 21 Bible Verse: He Saved Us Titus 3:5-7, ESV
- 22 Extra Bible Verse: I Will Give You a New Heart Ezekiel 36:26, ESV

Big Question 11, Bible Truth 1 Overview: Key Concepts

p.1

Unit 11: The God Who Saves

Unit Big Question (and Answer): How Can We Be Saved? It Is God's Free Gift!

Unit Bible Verse: "For the wages of sin is death, but the free gift of God is eternal life in Christ Jesus our Lord."
--- Romans 6:23, ESV

Bible Truth 1 Concept: It's God's Free Gift... When We Tell God Our Sins and Turn Away from Them!

We are all sinners who disobey God. We hear God's laws from the Bible and we know that we have broken them. We hear how we are supposed to love God and His good ways, and we know that we do not. We hear about God's punishment for sin, and we know that we deserve it.

But God is so merciful! He has provided a way to save us from His punishment. How? God wants us to tell (confess) our sins to Him and ask for His forgiveness through His Son, Jesus, who died on the cross to take the punishment for the sins of God's people. And, God wants us to turn away from a life of disobeying Him and ask Him to help us to live for Him instead (that's what it means to repent of our sins.)

If we do these things, God promises to forgive our sins and make us His very own people. We will get to know Him in our hearts by His Holy Spirit now. And one day, when we die, we will go to live perfectly happily with Him forever.

Bible Truth 1 Bible Verse: 1 John 1:8-9

"If we say we have no sin, we deceive ourselves, and the truth is not in us. If we confess our sins, he is faithful and just to forgive us our sins and to cleanse us from all unrighteousness."

Learn a Little: "If we confess our sins, he is faithful to forgive our sins."

Meaning

This verse reminds us that we are all sinners. We deceive ourselves if we think we are not. But, the good news is, that if we admit we are sinners and confess our sins to God, He is faithful and just and will forgive us our sins and save us through Jesus.

Bible Truth 1 ACTS Prayer

- A** God, we praise You for being faithful and just, and able to forgive our sins.
- C** God, we confess that we are all sinners who need You to save us. We can never be acceptable to You on our own. We need Jesus to save us!
- T** Thank You, God, for being willing to forgive all our sins, when we confess them, turn away from them, and trust in Jesus as our Savior.
- S** God, work in our hearts. Show us our sins and our need for Jesus to save us. Help us to confess our sins to You and turn away from them. Help us to trust in Jesus as our Savior. Be our Heavenly Father! Make us Your adopted children who love You and whom You will love forever.

In Jesus' name we pray, Amen.

Bible Truth 1 Story

The Case of the Changed Climber

Luke 19:1-9

Big Question 11, Bible Truth 1 Overview: Key Concepts

p.2

Songs Used in Bible Truth 1

Big Q & A 11 Song

Big Question 11 Song: How Can I Be Saved?

Big Question 11 Bible Verse Song: The Free Gift of God Is Eternal Life Romans 6:23, ESV

Big Question 11 Hymn: Grace Greater than All Our Sin, refrain

Big Question 11 Praise Song: Blessed Be the Name

Bible Truth 1 Bible Verse Song: If We Say We Have No Sin 1 John 1:8-9, ESV

Extra Bible Truth 1 Bible Verse Song: If We Say 1 John 1:8-9, ESV

listen to or download songs for free at <https://praisefactory.org>: Deep Down Detectives Music page

1. GETTING STARTED ★ = follow the stars for a short & simple lesson plan

<p>Intake Activity Ideas</p>	<p>Choose one of these open-ended activities to include children as they join the class:</p>														
<p>Free Play Time <i>suggestions in Appendix D</i></p>	<p>★ Offer your own or some of the easy-to-make, free play activities suggested in Appendix D.</p>														
<p>OR Sing-along Music Time <i>lyrics and sheet music, Appendix A</i> <i>listen to or download songs for free at https://praisefactory.org:Deep Down Detectives Music page</i></p>	<p>Music from Deep Down Detectives (DDD) ESV Songs 11:</p> <table border="0"> <tr> <td>Big Q & A 11 Song</td> <td><i>DDD ESV Songs 11, track 12</i></td> </tr> <tr> <td>Big Question 11 Song</td> <td><i>DDD ESV Songs 11, track 13</i></td> </tr> <tr> <td>Big Question 11 (Unit) Bible Verse Song: The Free Gift of God Is Eternal Life Romans 6:23, ESV</td> <td><i>DDD ESV Songs 11, track 14</i></td> </tr> <tr> <td>Big Question 11 Hymn: Grace Greater than All Our Sin, refrain</td> <td><i>DDD ESV Songs 11, track 15</i></td> </tr> <tr> <td>Big Question 11 Praise Song: Blessed Be the Name</td> <td><i>DDD ESV Songs 11, track 16</i></td> </tr> <tr> <td>Bible Truth 1 Bible Verse Song: If We Say We Have No Sin 1 John 1:8-9, ESV</td> <td><i>DDD ESV Songs 11, track 17</i></td> </tr> <tr> <td>Extra Bible Truth 1 Bible Verse Song: If We Say 1 John 1:8-9, ESV</td> <td><i>DDD ESV Songs 11, track 18</i></td> </tr> </table> <p><i>Add more fun to Sing-along Music Time by adding a Music, Movement & Memory Activity. These activities are listed on p.10 of this lesson plan with the Response Activities. Instructions found in Appendix B.</i></p>	Big Q & A 11 Song	<i>DDD ESV Songs 11, track 12</i>	Big Question 11 Song	<i>DDD ESV Songs 11, track 13</i>	Big Question 11 (Unit) Bible Verse Song: The Free Gift of God Is Eternal Life Romans 6:23, ESV	<i>DDD ESV Songs 11, track 14</i>	Big Question 11 Hymn: Grace Greater than All Our Sin, refrain	<i>DDD ESV Songs 11, track 15</i>	Big Question 11 Praise Song: Blessed Be the Name	<i>DDD ESV Songs 11, track 16</i>	Bible Truth 1 Bible Verse Song: If We Say We Have No Sin 1 John 1:8-9, ESV	<i>DDD ESV Songs 11, track 17</i>	Extra Bible Truth 1 Bible Verse Song: If We Say 1 John 1:8-9, ESV	<i>DDD ESV Songs 11, track 18</i>
Big Q & A 11 Song	<i>DDD ESV Songs 11, track 12</i>														
Big Question 11 Song	<i>DDD ESV Songs 11, track 13</i>														
Big Question 11 (Unit) Bible Verse Song: The Free Gift of God Is Eternal Life Romans 6:23, ESV	<i>DDD ESV Songs 11, track 14</i>														
Big Question 11 Hymn: Grace Greater than All Our Sin, refrain	<i>DDD ESV Songs 11, track 15</i>														
Big Question 11 Praise Song: Blessed Be the Name	<i>DDD ESV Songs 11, track 16</i>														
Bible Truth 1 Bible Verse Song: If We Say We Have No Sin 1 John 1:8-9, ESV	<i>DDD ESV Songs 11, track 17</i>														
Extra Bible Truth 1 Bible Verse Song: If We Say 1 John 1:8-9, ESV	<i>DDD ESV Songs 11, track 18</i>														
<p>OR Bible Verse Memory Game <i>instructions found in Appendix B</i></p>	<p>Lesson 1 Game: Animal Cube Lesson 2 Game: Fill'er Up Lesson 3 Game: Lily Pad Jump</p> <p><i>These activities are also included on p.10 of this lesson plan with the Response Activities.</i></p>														

2. OPENING CIRCLE TIME (*introduce the Bible Truth and tell the related Bible story*)

<p>Gathering the Children <i>lyrics and sheet music, Appendix A</i></p>	<p><i>Sing verse 1 of The Classroom Song to gather the children for Circle Time.</i></p> <p>The Classroom Song, verse 1 <i>DDD ESV Songs 11, track 1</i> Let's gather together to worship God, Let's gather together to worship God, Let's gather together to worship God, Come gather here with me!</p>
<p>Welcome to Deep Down Detectives</p>	<p>★ "Welcome to Deep Down Detectives. We're so glad you've joined us! Detectives are people who look for answers to questions. In Deep Down Detectives, we look for answers to big questions about God. We dig deep down in the truths of God's Word to find them."</p>

2. OPENING CIRCLE TIME, continued



= follow the stars for a short & simple lesson plan

<p>Deep Down Detectives Theme Song</p> <p><i>Lyrics and sheet music, Appendix A</i></p>	<p>"Let's sing our Deep Down Detectives Theme Song."</p> <p>★ Deep Down Detectives Theme Song <i>DDD ESV Songs 11, track 5</i></p> <p>We're Deep Down Detectives, diggin' deep in God's Word, For truths about God and His plans for this world, We're seeking to love Him, with all of our heart, We're Deep Down Detectives! Come on! Let's start!</p>
<p>Classroom Rules Song</p> <p><i>Lyrics and sheet music, Appendix A</i></p>	<p>There are two very important things that Deep Down Detectives do together: we worship God and we love one another. Our Classroom Rules Song reminds us how we should act. Let's sing it."</p> <p>Classroom Rules Song <i>DDD ESV Songs 11, track 6</i></p> <p>Shh, be quiet while someone is talking, Raise your hand, if you have something to say, Don't touch your friend, sitting beside you, Obey your teachers, Be kind as you play. These are our classroom rules, These are our classroom rules, They help us worship God and love one another, These are our classroom rules.</p>
<p>Opening Prayer Time</p> <p><i>Lyrics and sheet music, Appendix A</i></p>	<p>"Children, we need God's help to keep these rules. Let's ask Him to help us right now. Let's get ready and pray."</p> <p>Let's Pray <i>DDD ESV Songs 11, track 7</i></p> <p>1-2-3! Fold your hands, Bow your head, Close your eyes. Let's pray! (<i>repeat</i>)</p> <p>"Let's pray:"</p> <p>★ Opening Prayer</p> <p>Dear Lord, We're so glad to get to gather together to worship You! Please help us keep the classroom rules. Please help us to love You and learn about You today. In Jesus' name we pray. Amen.</p>

2. OPENING CIRCLE TIME, continued

★ = follow the stars for a short & simple lesson plan

Reveal the Big Question
Introduce the Big Question Box/Briefcase

lyrics and sheet music, Appendix A

“Detectives INVESTIGATE things. That means they ask questions and look for answers. Deep Down Detectives investigate big questions about God. The Big Question we are investigating today is right inside our Big Question Box/Briefcase.

The Big Question Box Song

DDD ESV Songs 11, track 8

We’ve got a big box,
All closed up and locked,
Filled with the truths of God’s Word.

We’ve got a brief case,
There’s no time to waste,
Come on, kids, let’s open it up!

The Big Question under Investigation

VISUAL take out AID



of BQB

Big Question & Answer Sign, front side

**found in the DDD Unit 11 Visual Aids, ESV Book*

Ok, who would like to open for me and pull out the Big Question?”

Choose a child to open the box/briefcase, take out the Big Question and hand it to you, then hold up the Big Question sign for all the children to see, and say:

★ The Big Question we are investigating today is Big Question Number 11:

How Can We Be Saved?

and the Answer is:

It Is God’s Free Gift!

Big Question Meaning

★ We all have disobeyed God. We have all lost the wonderful special closeness with God that He meant for us to have with Him. No matter how hard we try, we can’t ever be good enough to win back special closeness with God.

No, we can’t save ourselves, but God can. That’s why He sent Jesus: to save us as a free gift from Him. Anyone who says “sorry” to God for their sins and trusts in Jesus as their Savior, He will forgive all their sins. God will give them special closeness with Himself right now. Then one day, He will take them to live with Him forever. This is the free gift God offers to you and me. God is so kind to us!

Big Question Songs

★ “Let’s sing our Big Question Song:

Big Q & A 11 Song

Big Q & A 11 Song

DDD ESV Songs 11, track 12

lyrics and sheet music, Appendix A

(adapted version of “Here We Go Looby-Loo”)

How can we be saved?
How can we be saved?
How can we be saved?
It is God’s free gift!

2. OPENING CIRCLE TIME, continued



= follow the stars for a short & simple lesson plan

<p>Learning about the Big Question (use one or both)</p> <p>★</p>	<p>Repeat the Big Question and Answer again: "How Can We Be Saved? It Is God's Free Gift!"</p> <p>Say: "Hmmm, I wonder what that means... Let's do our action rhyme/sing our song that explains it."</p> <p>Then do the action rhyme or sing the song using any of the optional motions suggested, if desired.</p>	
<p>Big Question Action Rhyme</p>	<p>Big Question 11 Action Rhyme</p> <p>I disobey God, I need a Savior! You disobey God, You need a Savior! We all disobey God, We all need a Savior! Oh, what a sad, sad day!</p> <p>But... God has a wonderful, free gift for me! A wonderful, free gift for you! God has a wonderful, free gift for us all. God will forgive our sins through Jesus! Oh, what a happy, happy day!</p>	<p>(POSSIBLE ACTIONS)</p> <p><i>Point to self</i> <i>Point out to others</i></p> <p><i>extend arms out wide to each side</i> <i>make a sad face</i></p> <p><i>Point to self</i> <i>Point out to others</i></p> <p><i>extend arms out wide to each side</i> <i>cheer and jump up and down for this best of news</i></p>
<p>Big Question (Action Rhyme) Song</p> <p>★</p> <p><i>lyrics and sheet music, Appendix A</i></p>	<p>Big Question 11 Action Rhyme/ Song</p> <p>Refrain</p> <p>How can we be saved? How can we be saved? How can we be saved? It's God' free gift. How can we be saved? How can we be saved? How can we be saved? It's God's free gift through Christ.</p> <p>Verse 1</p> <p>I disobey God, I need a Savior, You disobey God, You need a Savior, We all disobey God, We need a Savior. To save us from our sins. <i>Refrain</i></p> <p>Verse 2</p> <p>Jesus, He paid the price, the perfect sacrifice, On the cross, gave His life, Bought us eternal life, Takes away all our sin, Makes our hearts clean within, When we repent and believe in Him. <i>Refrain</i></p>	<p><i>DDD ESV Songs 11, track 13</i></p> <p>(POSSIBLE ACTIONS)</p> <p><i>point up to God in heaven</i></p> <p><i>Point to self</i> <i>Point out to others</i></p> <p><i>extend arms out wide to each side</i></p> <p><i>make a cross with your index fingers</i></p> <p><i>Touch heart</i> <i>Make prayer hands and bow head</i></p>

2. OPENING CIRCLE TIME, continued

★ = follow the stars for a short & simple lesson plan

Learning the Bible Truth

VISUAL take out

AID



of BQB

VISUAL AID

All the Bible Truths Sign

★ "It is God's free gift" is a good beginning, but there's so more to learn. So it's time for us to dig down even deeper for more answers to our Big Question about God. We're going to be learning **THREE** Bible truths that all tell us more about this wonderful, free gift God offers us.

Who would like to hand me the picture with our three Bible truths on it? It's in the Big Question Box/Briefcase." *Choose a child to get it and hand it to you, then hold it up and show them the pictures of the three truths they will be learning.*

Bible Truth Clue

VISUAL take out

AID



of BQB

Bible Truth Clue Sign,

front side

VISUAL AID

After everyone has had a good look, say...

"Ok, now let's look at our Bible Truth Clue sign and see if we can figure out which of these three truths we will be learning about today. Who would like to get it out of the Big Question Briefcase for me?"

Choose a child to open the briefcase, take out the Bible Truth Clue sign and hand it to you. Hold up the front side for the children to see. Cover up the answer, written along the bottom, and say:

**"How Can We Be Saved?
It Is God's Free Gift!
When We Tell God Our ???? and Turn Away from Them!"**

Hint

We're missing one word. Here's the hint to what the missing word is. It says: "What is the Bible word for disobeying God and His good laws? It starts with an "s" and it rhymes with "ends."

Can you guess? It's "SINS."

So the Bible Truth we are learning today is:

(uncover answer from bottom of sign, show it to them and say:)

★ **"How Can We Be Saved?
It Is God's Free Gift!
When We Tell God Our SINS and Turn Away from Them!"**

Bible Truth Meaning

★ And here is what this Bible Truth means: *(read the meaning off of the back of the sign, say:)*

We are all sinners who disobey God. We hear God's laws from the Bible and we know that we have broken them. We hear how we are supposed to love God and His good ways, and we know that we do not. We hear about God's punishment for sin, and we know that we deserve it.

But God is so merciful! He has provided a way to save us from His punishment. How? God wants us to tell (confess) our sins to Him and ask for His forgiveness through His Son, Jesus, who died on the cross to take the punishment for the sins of God's people. And, God wants us to turn away from a life of disobeying Him and ask Him to help us to live for Him instead (that's what it means to repent of our sins.)

If we do these things, God promises to forgive our sins and make us His very own people. We will get to know Him in our hearts by His Holy Spirit now. And one day, when we die, we will go to live perfectly happily with Him forever.

2. OPENING CIRCLE TIME, continued



= follow the stars for a short & simple lesson plan

Learning the Bible Verse

"And how do I know this is true? God tells me so in His special book, the Bible."

The Bible Chant Song

Say or sing the Bible Chant Song.

DDD ESV Songs 11, track 9

lyrics and sheet music, Appendix A

The Bible Chant Song

The Bible, the Bible,
Let's get out the Bible.
Let's hear what God has to say.
The Bible, the Bible,
God's given us the Bible.
It's His Word for us to learn and obey! Yay!

Bible Verse

DDD 11.1 Bible Verse-front side (in the DDD Bible folder)

"Who would like to get our Bible folder out of the Big Question Briefcase for me?"

VISUAL AID Place verse in take out



of BQB
DDD Bible Folder

Choose a child to open the briefcase, take out the "Bible" folder and hand it to you. Remove the Bible Verse Picture from the "Bible" folder and hold it up for all the children to see, then say:

1 John 1:8-9 tells us:

1 John 1:8-9, ESV

"If we say we have no sin, we deceive ourselves, and the truth is not in us. If we confess our sins, he is faithful and just to forgive us our sins and to cleanse us from all unrighteousness."

Learn a Little: "If we confess our sins, he is faithful to forgive our sins."

*found in the DDD Unit 11 Visual Aids, ESV Book

Bible Verse Meaning

What does that mean?

This verse reminds us that we are all sinners. We deceive ourselves if we think we are not. But, the good news is, that if we admit we are sinners and confess our sins to God, He is faithful and just and will forgive us our sins and save us through Jesus.

2. OPENING CIRCLE TIME, continued

 = follow the stars for a short & simple lesson plan

**Bible Verse
Song**

*lyrics and sheet music,
Appendix A*

You might also enjoy:

*If We Say 1 John 1:8-9, ESV
DDD ESV Songs 11, track 18*

We've said our Bible verse, now let's sing it!

If We Say We Have No Sin 1 John 1:8-9

DDD ESV Songs 11, track 17

If we say we have no sin,
If we say we have no sin,
If we say we have no sin,
We deceive ourselves,
And the truth is not in us.

But...If we confess our sins...
He is faithful and just to forgive us our sins,
Faithful and just to forgive us our sins,
Faithful and just to forgive us our sins,
And to cleanse us from,
All unrighteousness.

First John One, verses eight and nine.

Lesson Plan: Big Question 11, Bible Truth 1







use with all THREE lessons

p.8

2. OPENING CIRCLE TIME, continued



= follow the stars for a short & simple lesson plan

<p>Getting into the Case</p>	<p>"Now it's time to do a bit more deep down investigating. Let's see what Detective Dan wants us to help him figure out. Would someone like to get it out for me?"</p>
<p>Listening Assignments</p> <p>Place in  take out  of BQB</p>	<p>NOTE: Listening assignments are most suitable for ages 3+. Skip straight to the Bible story (see bottom of this page), if working with 2 year olds.</p> <p>"Let's open up our listening assignment and see what we are supposed to figure out today.</p> <p>Choose a child to take out the Listening Assignment (from the DDD Bible Folder) and hand it to you. Read Detective Dan's letter to the children that includes the listening assignment. The listening assignments are summarized below:</p>
<p>VISUAL AID</p> <p></p> <p>DDD Unit 11 Visual Aids, ESV</p>	<p>Detective Dan's Lesson #1 Listening Assignment:</p> <p>I need to find out:</p> <ol style="list-style-type: none"> 1. Who was the climber and why did he climb? 2. How did he change?
<p>VISUAL AID</p> <p></p> <p>DDD Unit 11 Visual Aids, ESV</p>	<p>Detective Dan's Lesson #2 Listening Assignment:</p> <p>Our Bible Verse is 1 John 1:8-9, ESV</p> <p>"If we say we have no sin, we deceive ourselves, and the truth is not in us. If we confess our sins, he is faithful and just to forgive us our sins and to cleanse us from all unrighteousness."</p> <p>I need to find out:</p> <ol style="list-style-type: none"> 1. Who wanted to confess his sins and be forgiven by God? 2. Who didn't think he should be forgiven? Who did think he should be forgiven?
<p>VISUAL AID</p> <p></p> <p>*Listening Assignment #3 includes the Assignment Sheet, plus 6 clue pictures*</p> <p>DDD Unit 11 Visual Aids, ESV</p>	<p>Detective Dan's Lesson #3 Listening Assignment:</p> <p>I found six clues, but only 4 of them are in the story. Our six clues were: a tree, a cow, a bag of money, a king, an umbrella, and yummy food. Hold each of them up for the children to see as you identify them.</p> <p>I need to figure out:</p> <ol style="list-style-type: none"> 1. Which four belong in the story and which two don't? 2. Who confessed their sins to God and was forgiven? Who gave back the money he had stolen?
<p>Tell the Bible Story</p> <p>Place story & pics in  take out  of BQB</p> <p>DDD Unit 11 Visual Aids, ESV</p> <p>Story text included in this book right after this lesson plan and in Visual Aids book</p>	<p>Then say, "Ok, Deep Down Detectives! Put on your best listening ears and see if you can hear the answers to Detective Dan's questions. When I finish telling the story, we will see if we can answer all the questions."</p> <p>Bible Story: The Case of the Changed Climber Luke 19:1-9</p> <p>Read the Bible Truth story, putting up the storyboard pictures as you tell it. Then, have the children answer the listening assignment. Present the gospel and lead in prayer.</p> <p>*Answers to questions; the gospel; and, ACTS prayer are included with the story text.*</p>

2. OPENING CIRCLE TIME, continued

★ = follow the stars for a short & simple lesson plan

<p>Story Response Song(s)</p> <p>Hymn</p> <p><i>lyrics and sheet music, Appendix A</i></p>	<p><i>As attention span and time allow, you might want to end with one of the following songs which also tie in with the unit. If desired, use the Music and Movement activity ideas while singing, listed with the Response Activities.</i></p> <p>Grace that Is Greater than All Our Sin <i>DDD ESV Songs 11, track 15</i></p> <p>Verse 1 Grace, grace, God’s grace, Grace that will pardon and cleanse within; Grace, grace, God’s grace, Grace that is greater than all our sin.</p> <p>Tie-in: “Children do you know what the word “grace” means? It means a free gift that we don’t deserve! And what grace--what free gift-- does God offer us through Jesus? To forgive us and save us from the punishment we deserve for disobeying God! Let’s sing of God’s marvelous grace!”</p>
--	---

<p>Praise Song</p> <p><i>lyrics and sheet music, Appendix A</i></p>	<p>Praise Song: Blessed Be the Name <i>DDD ESV Songs 11, track 16</i></p> <p>All praise to Him who reigns above, In majesty supreme. Who gave His Son for man to die, That He might man redeem!</p> <p>Tie-in: “How can we be saved? It is God’s free gift through the Lord Jesus! There would be no hope for us, if God did not send Jesus to be our Savior. That’s why God’s people love to bless His name. They are so grateful that He paid for their sins so that they can know God and live with Him forever!”</p>
--	--

3. TAKING ACTION: Response Activities *(choose from among these activities)*





<p>Transition to Activities</p>	<p>★ Well, Deep Down Detectives, you’ve done a great job diggin’ deep down for answers in the truths of God’s Word. Now it’s time to enjoy some activities.”</p> <p><i>Tell children what activity/s you are providing for them: eTher free play or some of the response activities listed below. When you are ready to dismiss them, use this song to help the children transition in an orderly fashion to their next activity.</i></p> <p>“Children, let’s sing our Time to Play Song. When we are finished you may get up and walk over to our next activity.”</p>
--	--

<p>Classroom Song, verse 2</p> <p><i>lyrics and sheet music, Appendix A</i></p>	<p>Classroom Song, verse 2 <i>DDD ESV Songs 11, track 2</i></p> <p>We’ve gathered together to worship God, We’ve gathered together to worship God, And now it’s time to play.</p> <p><i>Dismiss the children to whatever activities you have prepared for them to do.</i></p>
--	---

Lesson Plan: Big Question 11, Bible Truth 1

use with all THREE lessons

3. TAKING ACTION: Response Activities *(choose from among these activities)* ★ = short & simple lesson plan

<p>Response Activities</p>	<p>Choose one or more activities appropriate for your children, based on classroom time and developmental needs. Add the Discussion Sheet to any activity for deeper learning. ★</p>
<p>Bible Verse Memory Game</p> <p><i>game directions, Appendix B</i></p>	<p>Though listed with the opening activities, you may choose to use this Bible verse game here instead (or as a repeat).</p> <ul style="list-style-type: none"> Lesson 1 Game: Animal Cube Lesson 2 Game: Fill'er Up Lesson 3 Game: Lily Pad Jump <p>Use the Discussion Sheet with this activity for even deeper learning ★</p>  <p>Discussion Questions</p>
<p>Music, Movement & Memory Activity</p> <p><i>game directions, Appendix B</i></p>	<p>A music activity that uses the songs from the Bible Truth and Big Question unit.</p> <ul style="list-style-type: none"> DDD Songs for this Bible Truth, plus: Lesson 1 Activity: Egg Shakers Lesson 2 Activity: Jingle Bell Hands Lesson 3 Activity: Big Voice, Little Voice <p>Use the Discussion Sheet with this activity for even deeper learning ★</p>  <p>Discussion Questions</p>
<p>Bible Story Review Game</p> <p><i>game directions, Appendix B</i></p>	<p>A game that uses the storyboard pictures from the story to review the story.</p> <ul style="list-style-type: none"> Lesson 1 Game: Deep Down Detectives Clue Hunt Lesson 2 Game: Run to the Grocery Store Lesson 3 Game: Who's in the Basket? <p>Use the Discussion Sheet with this activity for even deeper learning ★</p>  <p>Discussion Questions</p>
<p>Coloring Pages/ Take Home Sheets</p> <p><i>in Appendix C</i></p> <p>★</p>	<p>A coloring page related to the lesson assignment question is provided for each lesson. On the back of each are the key concepts, a few questions and a song for parents to use with their children.</p> <p>NOTE: Upgrade your coloring sheet to a more interesting craft by offering simple embellishments, such as jiggly eyes, craft sand, glitter, glitter glue, colored paper dots (made with a hole punch), fabric scraps, etc. Make cut-to-size glued-on clothes, hair, etc for characters by using a copy of the coloring sheet, cutting out the portions and making them the patterns for whatever you want to cut out of fabric, paper, foil, etc.</p> <ul style="list-style-type: none"> Lesson 1 Coloring Sheet Emphasis: Bible Truth Lesson 2 Coloring Sheet Emphasis: Bible Verse Lesson 3 Coloring Sheet Emphasis: ACTS Prayer <p>Use the Discussion Sheet with this activity for even deeper learning ★</p>  <p>Discussion Questions</p>
<p>Extra Crafts: Big Question Craft</p> <p><i>in Appendix C</i></p> <p>Bible Verse Craft</p> <p><i>in Appendix C</i></p> <p>Bible Story Puzzle</p> <p><i>in Appendix C</i></p>	<p>These crafts are slightly more complex than the coloring/take home sheets:</p> <p>The Bible Concept Go-and-Tell Craft is a craft that summarizes the Bible concept and includes the Bible verse is included for those desiring more than a coloring sheet. This more complex craft will involve gluing, sticking, etc. Can be used at any time.</p> <p>The Bible Story Coloring Sheet provides a tie in between the Bible story and the Bible truth they are learning.</p> <p>The Storyboard Picture Placement Page has been made into a puzzle that can be cut out and re-assembled by the children. This provides a nice summary of the story.</p> <p>Use the Discussion Sheet with these activities for even deeper learning ★</p>  <p>Discussion Questions</p>
<p>Free Play Activities ★</p> <p><i>ideas in Appendix D</i></p>	<p>Offer your own or some of the easy-to-make, free play activities suggested in Appendix D.</p>

4. CLOSING CIRCLE TIME *(End-of-session activities for the last 5-10 minutes of class time)*

★ = short & simple lesson plan

<p>Transition to Closing Circle</p> <p>Classroom Song, verse 3</p> <p><i>lyrics and sheet music, Appendix A</i></p>	<p><i>Use this song to help the children transition in an orderly fashion. Start singing this song and ask the children to gather with you for Closing Circle Time.</i></p> <p>Classroom Song, verse 3 <i>DDD ESV Songs 11, track 3</i></p> <p>It's time to get ready to go and tell, It's time to get ready to go and tell, Come gather here with me.</p>
<p>Closing Circle Time</p> <p>Classroom Song, verse 4</p> <p><i>lyrics and sheet music, Appendix A</i></p>	<p><i>When children are settled in the circle, say:</i></p> <p>"It's almost time for your parents to come pick you up. And do you know what that means? It means.... (draw this out to build anticipation and excitement)...that it's almost time to go home and...it's almost time to...Go and Tell! We have learned some big news about God today. God wants us to take and tell it to the whole world!"</p> <p>Classroom Song, verse 4 <i>DDD ESV Songs 11, track 4</i></p> <p>So what's our big news to go and tell, So what's our big news to go and tell, Can you tell me now?</p>
<p>Big News to Tell</p> <p>Big Question 11</p> <p><i>VISUAL AID</i></p> <p>#1</p> <p><i>*found in DDD Unit 11 Visual Aids, ESV Book lyrics and sheet music, Appendix A</i></p> <p>Big Question 11, Bible Truth 1</p> <p><i>VISUAL AID</i></p> <p>#3</p>	<p>"Let's see....there's so much big news to tell! There's so much we've learned!</p> <p>First of all, can you tell me the answer to our Big Question: "How Can We Be Saved?"</p> <p><i>Hold up the Bible Truth Clue Picture.</i></p> <p>Say the answer with me: "It Is God's Free Gift!"</p> <p><i>(If desired, you can sing one/both of the Big Question songs.)</i> <i>DDD ESV Songs 11, tracks 12,13</i></p> <p>And what's one way He does this? What did we learn? <i>Point to the picture.</i></p> <p>When We Tell God Our Sins and Turn Away from Them!</p> <p>"And how do I know this is true? Can you tell me?"</p> <p>Say it with me: "The Bible tells me so!" That's right!</p>
<p>Big Question 11 Bible Truth 1 Bible Verse</p> <p><i>VISUAL AID</i></p> <p>#4</p> <p><i>*found in the DDD Unit 11 Visual Aids, ESV Book lyrics and sheet music, Appendix A</i></p>	<p>We learned: 1 John 1:8-9, ESV</p> <p>"If we say we have no sin, we deceive ourselves, and the truth is not in us. If we confess our sins, he is faithful and just to forgive us our sins and to cleanse us from all unrighteousness."</p> <p>Learn a Little: "If we confess our sins, he is faithful to forgive our sins."</p> <p>What does that mean?</p> <p>This verse reminds us that we are all sinners. We deceive ourselves if we think we are not. But, the good news is, that if we admit we are sinners and confess our sins to God, He is faithful and just and will forgive us our sins and save us through Jesus.</p> <p><i>(If desired, you can sing the Bible verse song.)</i> <i>DDD ESV Songs 11, track 17</i></p>

4. CLOSING CIRCLE TIME, continued



= follow the stars for a short & simple lesson plan

<p>Closing ACTS Prayer Time</p> <p>ACTS Prayer Chant</p> <p><i>lyrics and sheet music, Appendix A</i></p>	<p><i>Let's ask God to help us to remember this and even tell others this good news. Let's get ready and pray our ACTS prayer.</i></p> <p><i>And what does ACTS mean? Let's sing/say our ACTS Prayer Chant!</i></p> <p>ACTS Prayer Chant Song <i>DDDESV Songs 11, tracks 10,11</i></p> <p>A, Adoration, God, we praise You! C, Confession, Forgive us our sins. That's the ACTS prayer, my friend, T, Thanksgiving, Thank You for Jesus, Bow your head, Close your eyes, Shhh, S, Supplication, Help us to live like Him. Let's begin.</p>
<p>Closing ACTS Prayer</p>	<p>"Let's pray!"</p> <p><i>Lead the children in the ACTS prayer for this Bible Truth.</i></p> <p>A God, we praise You for being faithful and just, and able to forgive our sins.</p> <p>C God, we confess that we are all sinners who need You to save us. We can never be acceptable to You on our own. We need Jesus to save us!</p> <p>T Thank You, God, for being willing to forgive all our sins, when we confess them, turn away from them, and trust in Jesus as our Savior.</p> <p>S God, work in our hearts. Show us our sins and our need for Jesus to save us. Help us to confess our sins to You and turn away from them. Help us to trust in Jesus as our Savior. Be our Heavenly Father! Make us Your adopted children who love You and whom You will love forever.</p> <p>In Jesus' name we pray, Amen.</p>
<p>5. TAKING IT HOME <i>(Take Home Sheet)</i></p>	
<p>Clean up and Dismissal </p>	<p>"Now it's time to work together and clean up." <i>Have the children join you in cleaning up the room.</i></p>
<p>Coloring Pages/ Take Home Sheets </p> <p><i>in Appendix C</i></p>	<p><i>Give out the craft/take home sheet and any other papers from the session, as you dismiss children from class.</i></p> <p><i>(Reminder: The back side of the coloring page is the take home sheet for each lesson.)</i></p>
<p>Bible Story to Take-Home</p> <p><i>in Appendix C</i></p>	<p>You may also want to include a copy of the story along with the take home sheet. (However, each coloring sheet/take home sheet includes a note to parents telling where they can download the story from the Parent Resources section on the website.</p>

The Case of the Changed Climber*Luke 19:1-9*

of BQB

Story-telling Tips

Ahead of time:

1. Read the Bible verses and story. Pray!
2. Choose story action cues and prepare storyboard figures/Story Scenes, if using. (In Visual Aids book)
3. Practice telling story with the storyboard figures/Story Scenes, timing your presentation. Shorten, if necessary.

During your presentation:

1. Maintain as much eye contact as possible as you tell the story.
2. Put up storyboard figures/add story action cues/hold up Story Scenes as you tell the story. Allow the children to help you put them on the board, if desired.
3. Include the children in your story with a few questions about what they think will happen or words/concepts that might be new to them.
4. Watch the kids for signs that their attention span has been reached. Shorten, if necessary.

INTRODUCTION/ LISTENING ASSIGNMENTS

“Our story is called: The Case of the Changed Climber. Here is your listening assignment.” Read from Detective Dan’s Listening Assignment signs, but questions are summarized below:

Detective Dan’s Lesson #1 Listening Assignment:

I need to find out:

1. Who was the climber and why did he climb?
2. How did he change?

Detective Dan’s Lesson #2 Listening Assignment:**Our Bible Verse is 1 John 1:8-9, ESV**

“If we say we have no sin, we deceive ourselves, and the truth is not in us. If we confess our sins, he is faithful and just to forgive us our sins and to cleanse us from all unrighteousness.”

I need to find out:

1. Who wanted to confess his sins and be forgiven by God?
2. Who didn’t think he should be forgiven? Who did think he should be forgiven?

Detective Dan’s Lesson #3 Listening Assignment:

I found six clues, but only 4 of them are in the story.

Our six clues were: a tree, a cow, a bag of money, a king, an umbrella, and yummy food.

Hold each of them up for the children to see as you identify them.

I need to figure out:

1. Which four belong in the story and which two don’t?
2. Who confessed their sins to God and was forgiven? Who gave back the money he had stolen?

Read the assignment questions, THEN SAY,

“Ok, Deep Down Detectives! Put on your best listening ears and see if you can hear the answers to Detective Dan’s questions. When I finish telling the story, we will see if we can answer all the questions.”

Read the Bible Truth story, answer questions, present the gospel and lead in prayer.

Answers to questions; the gospel; and, ACTS prayer are included with the story text.

The Case of the Changed Climber *Luke 19:1-9**Story with lines separating paragraphs (text in bold, optional interaction cues in italics)*

Zacchaeus was a rich, rich, rich man! He could have lots of fine clothes. He could have a big, big house. He could eat all the yummiest foods. He could buy all the nice things he liked. Yes. Zacchaeus could have almost anything he wanted because he was so rich.

But even though Zacchaeus could have almost ANYTHING he wanted, and almost ANYTHING money could buy, there was something that Zacchaeus did NOT have. It was something money could NOT buy.

What do you think Zacchaeus wanted that money could not buy?

Zacchaeus wanted God to forgive his sins.

Now, we know that no one deserves God's forgiveness of their sins. We have all disobeyed God. We all deserve His punishment. But to many, Zacchaeus ESPECIALLY didn't deserve to have his sins forgiven.

You see, Zacchaeus had chosen to work for Caesar, the big king in Rome. Caesar's soldiers had taken over Israel, the country where Zacchaeus and the other people lived. And one of the big things Caesar wanted from the people in Israel was MONEY. TAX MONEY.

The people of Israel hated to give the Roman king tax money, and most of them refused to help him collect it. But not Zacchaeus. Zacchaeus loved money and when the king offered to give him lots of money to collect taxes, Zacchaeus agreed.

"Zacchaeus, collect my tax money, and any extra you get, you can keep for yourself," the big, Roman king promised.

So, that's what Zacchaeus did. He became the head tax collector in the important city of Jericho. Zacchaeus and his men worked to get lots of money for Caesar and for themselves. Zacchaeus set up a booth along the road outside of Jericho. He stopped everyone along the road and made them pay taxes on their things. "Stop! No one passes by without paying the king's tax," demanded Zacchaeus and his men. They did the same thing to the people of Jericho. Zacchaeus and his men knocked on every door. "Bang, bang, bang! Pay your tax money right now," they ordered everyone.

Rich people, poor people. Healthy people, sick people. Everyone was ordered to pay, no matter how hard it was for them. No one wanted to pay. Many couldn't pay. But that didn't stop Zacchaeus. He and his men took soldiers with them to do whatever was needed to make people pay. So, pay they did, the amount Caesar wanted for his taxes, and a lot more that Zacchaeus and his men kept for themselves. Zacchaeus didn't mind if the people were scared. He didn't mind if he took too much money or made their lives sad. He didn't care what happened to anyone else. He only wanted more money for himself.

So, that's how Zacchaeus got to be so rich, rich, rich. And that's why people of Jericho and many others, thought Zacchaeus ESPECIALLY didn't deserve God's forgiveness.

"How could God forgive someone like Zacchaeus", they exclaimed. "He such a mean old greedy bully. Surely there is no forgiveness for someone like that!"

What do you think? Were the people right? Could Zacchaeus ever find God's forgiveness?

Story with lines separating paragraphs (text in bold, optional interaction cues in italics)

You might think all that money made Zacchaeus happy, and perhaps it did for a while. You see, fine clothes, a big, big house, yummy food, nice things are wonderful to have; but in the end, all those good things are never enough.

Why do you think all those good things would never be enough to make Zacchaeus happy?

Why? Because God made us to know, love, and obey Him. He, alone, can make us truly happy.

And that's why deep down in his heart, Zacchaeus was very UN-happy, even with all that money and those nice things. They would never be enough to satisfy him.

What was worse, Zacchaeus knew God's laws, and he knew that he had broken them. He had done many terrible things to the people in his town and the people who passed along the road. He had hurt those people and now they hated him.

Zacchaeus knew that he had chosen to turn away from God and His good ways. He had rebelled against God and deserved His punishment. It seemed like there was no way for Zacchaeus to come back to God now. Why, a man who had done such bad things wasn't even allowed to go in the worship house to worship God! How could a man this bad ever find forgiveness from God? Surely, there was no way!

Do you think there was no way for a bad man like Zacchaeus to come to God?

But there WAS a way to be forgiven. God had made a way through His Son, Jesus, as Zacchaeus found out one day.

Jesus and a crowd of people were passing through Jericho on the way to the big city of Jerusalem.

"Jesus is coming! Jesus is coming!" the exciting news spread throughout the town. Many gathered along the side of the road to see Jesus, squeezing together until there was no more room. Everyone wanted to hear Jesus teach about God and watch Him do amazing things by God's great power.

Zacchaeus tried to join the crowd to see Jesus, too, but no one would make room for him. Zacchaeus stood behind the crowd and tried to look over their heads, but he was such a short, little man that he couldn't see anything. Oh, if someone would just let him through to the front so he could see Jesus, too! But why would people help HIM after all the terrible things he had done?

"I must see Jesus! I must see Jesus!" Zacchaeus thought. He would not give up. Up! Why that was it. Zacchaeus had an idea.

What do you think Zacchaeus was going to do?

Zacchaeus would climb up a tree, then he could see Jesus without anyone getting in his way.

So, that's just what Zacchaeus did! He ran down the road, beyond the crowd, and climbed up a big, sycamore tree. Zacchaeus sat on his tree branch and watched as Jesus and the crowd with him came closer and closer and closer. What would happen? Would Jesus see Zacchaeus?

Do you think? Would Jesus see Zacchaeus hiding up in that tree?

Story with lines separating paragraphs (text in bold, optional interaction cues in italics)

It would have been so easy for Jesus to miss the short, little man hiding up among the leaves. But Jesus did NOT miss Zacchaeus. Jesus was LOOKING for him. Jesus knew all the terrible things Zacchaeus had done. He knew the sin in Zacchaeus' heart that made him so unhappy and separated him from God. And, Jesus knew that He could bring Zacchaeus the forgiveness from God he longed for.

So, instead of passing by Zacchaeus, Jesus led the crowd of people right up to that tree and stopped. He looked up through the leaves and straight at Zacchaeus.

What would Jesus say to Zacchaeus? What would Jesus DO to Zacchaeus? Zacchaeus was such a bad man and Jesus was so good! Would Jesus say angry things to Zacchaeus for all the bad things he had done? Would Jesus tell him there was no hope for a bad man like him?

What do you think Jesus would say to Zacchaeus?

Jesus had GOOD news for Zacchaeus. He had come to bring people like him to God! People who knew they had broken God's laws. Jesus had come to bring them God's forgiveness and to save them from God's punishment, no matter how bad they had been.

So, Jesus looked up at Zacchaeus, and said, "Zacchaeus, hurry and come down, for I must stay at your house today!"

Zacchaeus was shocked and so happy. Good teachers like Jesus never asked to stay at the house of bad men like him, no matter how rich they were. Zacchaeus knew what this meant. Jesus wasn't just asking to stay at his big house to enjoy his nice things and yummy food. Jesus was asking to stay at his house to welcome him back to God.

Oh, what wonderful news! More than all the fine clothes, the big house, the yummy food, and the nice things in the world, Zacchaeus wanted to be welcomed back by God. Oh, how he wanted God to forgive his sins!

Right then and there, God's Holy Spirit did a wonderful thing in Zacchaeus' heart. He helped Zacchaeus turn away from disobeying God and trust in Jesus as his Savior. Zacchaeus was forgiven by God for all the terrible things he had done. God had saved Zacchaeus through Jesus!

The town's people were shocked at Jesus' words and very unhappy!

Why do you think they weren't happy?

""How can Jesus stay with such a bad man who's done such terrible things and broken God's laws? Zacchaeus has lied and cheated us. He has shouted at us and hurt us. Zacchaeus has used soldiers to scare us. He's not even allowed in the worship place, he's so bad! A good teacher like Jesus shouldn't have anything to do with Zacchaeus, and He CERTAINLY shouldn't stay at his house!" they grumbled.

Jesus and Zacchaeus knew the people were right. Zacchaeus had been a very bad man. He had done terrible things and broken God's laws. He didn't deserve for Jesus to stay with him.

Story with lines separating paragraphs (text in bold, optional interaction cues in italics)

But Jesus and Zacchaeus knew the people were wrong about something, too. God had worked in Zacchaeus' heart. God had helped Zacchaeus turn away from his old, bad ways, and trust in Jesus as his Savior. God had forgiven Zacchaeus. Zacchaeus was a changed man!

Zacchaeus came down from that tree and showed just how changed he was. In front of everyone, he said, "Jesus, I'm going to give half of my money and nice things to poor people. And to the people I cheated, I'll give back everything I took and give them a whole lot more!" he promised.

"How amazing!" thought the town's people. "This doesn't sound like the same bad man who lied, cheated, and hurt us. This sounds like a NEW man, who loves God and wants to obey Him," they exclaimed.

And that's exactly what happened. God had changed Zacchaeus that day. God had helped him repent of his sins and trust in Jesus as his Savior.

Then, Jesus said to Zacchaeus and all the people, "God sent Me to seek and save people lost in their sins. And this is just what's happened today. God has forgiven Zacchaeus and made him one of His people!" Jesus! What a Savior for sinners!

Cracking the Case: (story wrap-up for Listening Assignments)

It's time to see how we did with our Listening Assignment.

Detective Dan's Lesson 1 Listening Assignment:**1. Who was the climber and why did he climb?**

Zacchaeus was the climber. He climbed up a tree, so he could see Jesus.

2. How did he change? Zacchaeus turned away from his sins. He stopped being a mean, greedy cheat. He put his trust in Jesus as his Savior and God forgave his sins and made him one of his people.

What about You and Me?

Like Zacchaeus, we All have disobeyed God and deserve his punishment. How sad! But like Zacchaeus, we, too, can confess our sins to God and turn away from them. We can trust in Jesus as our Savior. And if we do, God will forgive our sins and make us one of His people, just like He did for Zacchaeus.

Detective Dan's Lesson 2 Listening Assignment:**Our Bible Verse is 1 John 1:8-9, ESV**

"If we say we have no sin, we deceive ourselves, and the truth is not in us. If we confess our sins, he is faithful and just to forgive us our sins and to cleanse us from all unrighteousness."

1. Who wanted to confess his sins and be forgiven by God? Zacchaeus did.

2. Who didn't think he should be forgiven? Who did think he should be forgiven? The people in Zacchaeus' town of Jericho didn't think Zacchaeus should be forgiven by God. He was too bad of a man. But Jesus welcomed Zacchaeus to be forgiven by God.

What about you and me?

No one is too bad to be forgiven their sins by God. All who turn away from their sins and trust in Jesus as their Savior will be forgiven their sins and saved! God can do this for you and me, too. Ask Him! He loves to answer this prayer.

Detective Dan's Lesson 3 Listening Assignment:

Our six clues were: a tree, a cow, a bag of money, a king, an umbrella, and yummy food.

1. Which four belong in our story?

The tree, the bag of money, the king and the yummy food belong. The cow and the umbrella do not.

2. Who confessed their sins to God and was forgiven?**Who gave back the money he had stolen?**

Zacchaeus did.

For You and Me:

Like Zacchaeus we are sinners who need to confess our sins to God. Like Zacchaeus, if we do and turn to trust in Jesus as our Savior, God will forgive our sins we can become one of His dearly loved people forever.

The Gospel (story wrap-up if NOT using Listening Assignments)**Our Bible Truth is:****How Can We Be Saved?****It Is God's Free Gift...****"When We Tell God Our Sins and Turn Away from Them!**

Not just people like Zacchaeus who do lots of bad things need to be saved. We all do! For we all have chosen to disobey God and we all deserve God's punishment for our sins.

What good news we have, though! God promises to save all who turn away from disobeying Him and trust in Jesus as their Savior, even you and me!

Let's ask God to work in our hearts, just like He worked in Zacchaeus' heart. Let's ask Him to help us to turn away from disobeying Him and trust in Jesus as our Savior, so that we, too, might be saved.

Close in prayer.

Closing ACTS Prayer

- A** God, we praise You for being faithful and just, and able to forgive our sins.
- C** God, we confess that we are all sinners who need You to save us. We can never be acceptable to You on our own. We need Jesus to save us!
- T** Thank You, God, for being willing to forgive all our sins, when we confess them, turn away from them, and trust in Jesus as our Savior.
- S** God, work in our hearts. Show us our sins and our need for Jesus to save us. Help us to confess our sins to You and turn away from them. Help us to trust in Jesus as our Savior. Be our Heavenly Father! Make us Your adopted children who love You and whom You will love forever. In Jesus' name we pray, Amen.

Go to Lesson Plan, p.9 for the script to the rest of the lesson.

Deep Down Discussion Sheet

use with all THREE lessons

P.2

Questions to aid discussion of the key concepts and for use in games

<p>THE GOSPEL</p>	<p><i>What is God's good news for you and me? The gospel! How Can We Be Saved? It Is His Free Gift... When We Tell God Our Sins and Turn Away from Them. We all have chosen to disobey God and His good laws. We deserve His punishment, not His love. But God is so merciful that He made the way for us to be saved from our sins and become His people as His free gift. How? Through Jesus, His Son. Jesus lived a perfect life; then, on the cross, He gave it as the full payment for the sins of God's people. On the third day, Jesus rose from the dead. He had beaten sin and death for God's people. Now, we can receive God's free gift of salvation when we tell God our sins, turn away from them, and trust in Jesus as our Savior. Ask Him to help you. He loves to do this!</i></p>
<p>BIBLE TRUTH BIBLE VERSE</p> <p>Meaning</p> <p>Discussion Questions <i>(choose a few)</i></p>	<p>"If we say we have no sin, we deceive ourselves, and the truth is not in us. If we confess our sins, he is faithful and just to forgive us our sins and to cleanse us from all unrighteousness." --1 John 1:8-9, ESV</p> <p>Learn a Little: "If we confess our sins, he is faithful to forgive our sins."</p> <p>This verse reminds us that we are all sinners. We deceive ourselves if we think we are not. But, the good news is, that if we admit we are sinners and confess our sins to God, He is faithful and just and will forgive us our sins and save us through Jesus.</p> <ol style="list-style-type: none"> 1. If we say we are without sin, who do we deceive (who are we fooling)? <i>Ourselves.</i> 2. Who is faithful to forgive our sins, if we confess them to Him? <i>God is.</i> 3. What does God purify us from when we confess our sins to Him? <i>All unrighteousness. That means He treats us as if we have never disobeyed Him.</i> 4. What do we need to do for God to forgive our sins? <i>We need to confess our sins to God, telling Him that we know that we have disobeyed Him and deserve His punishment. We need to turn away from our sins and trust in Jesus as our Savior. God promises to forgive the sins of all who do!</i>
<p>BIBLE STORY</p> <p>Discussion Questions</p>	<p>The Case of the Changed Climber <i>choose a few</i></p> <ol style="list-style-type: none"> 1. What did Zacchaeus have? <i>Just about everything that money could buy.</i> 2. What did Zacchaeus want that money couldn't buy? <i>He wanted God's forgiveness.</i> 3. What kinds of bad things did Zacchaeus do to get all his money? <i>Good food, a nice house, beautiful clothes, and just about whatever else he wanted.</i> 4. What special place was Zacchaeus not allowed to go to because of the bad things he did? <i>The place to worship God.</i> 5. Why did Zacchaeus climb the tree? <i>He was too short to see Jesus and no one would make a place for him along the road.</i> 6. What did Jesus tell Zacchaeus to do? <i>To come down from the tree and take Him to his house to be his guest.</i> 7. What did Jesus offer Zacchaeus? <i>Forgiveness from his sins.</i> 8. What did Zacchaeus do that showed that he really had turned away from his sins and trusted in Jesus as his Savior? <i>He promised to pay back all the people whose money he had wrongly taken.</i> 9. Who worked in Zacchaeus' heart so that he would be changed? <i>The Holy Spirit.</i> 10. How can we have God's forgiveness for our sins? <i>By turning away from our sins and trusting in Jesus as our Savior.</i>

DEEP DOWN DETECTIVES

**Curriculum Resources
for Unit 11, Bible Truth 2:**



How Can We Be Saved?

It Is God's Free Gift...

**When We Trust in Jesus
As Our Own Savior!**

Session Prep (especially good for newbies!)

Pray!



Pray for the Holy Spirit to be at work in your and the children's hearts.

Review



If new to the curriculum, look at the **Getting Started with Deep Down Detectives section of the Core Curriculum book.** (p.5) It will be especially helpful to read through the Deep Down Detectives section of **The Praise Factory Tour: Extended Version Book.** This is a visual way to understand what goes on in the classroom. (A pdf of the book is found in the samples section on the website.)

Look through and Learn the Lesson



Read over **lesson plan.** Practice any **songs or action rhymes** you are using. Choose/make up motions to go with these. Choose less with younger children and more with older preschoolers. **Practice the lesson with the visual aids** and using the Big Question Box/Briefcase.

Read and Rehearse the Bible Story with Pictures



Read the Bible story from the Bible. Read the curriculum version. Practice telling it with the storyboard pictures. (If you have not previously laminated the story pictures, do that now.) Or, rehearse it from the Simple Story Scenes, if you are using those.

Let There Be Music



Download the music and listen to the songs. Choose which of the songs you will use with the children. If using live musicians, make sure they have the sheet music (Appendix A, Core Curriculum book).

Put the Props in Place



1. Prepare your Visual Aids. Put the Big Question, Unit Bible Truths, Bible Truth, Bible Verse, and Listening Assignment signs, as well as the Bible Story script in one side of the Bible folder.
2. Get out your storyboard. If using Simple Story Scenes, put these in your Bible Folder. Or, if using the individual storyboard figures, put all background pictures in place (they have a BG by the number). Put the rest of the storyboard pictures (these have a SB by the number) in order of use in the other side of the Bible folder.
3. Put the DDD Bible Folder as well as the Big Question sign in the Big Question Box/Briefcase and shut it. If your box/briefcase has locks and you want to use the unlocking the box as part of your session, lock it now....but make sure you have the key or know the code first.
4. Prepare the music CD or sheet music or mp3 device for use in your session.

Set Out Free Play Activities



Choose and set up free time activities you will use with the children. Choose a variety of different activities that will be enjoyed by different types of children. Rotate the activities you provide to keep them interesting and fresh to your children. (Suggestions in Appendix D, Core Curriculum books.)

Prepare Any Activities



Choose which (if any) of the Bible Truth games and crafts activities you want to use in the session. Bear in mind your time frame as well as the developmental abilities and attention span of your children as you decide which/how many to prepare. **Look over the Discussion Sheet** and choose a few questions you might use to spark discussion with the children as they do their activities (especially good for ages 3's+). Pray for God to give you opportunities to talk about these things with the children.

Let Them Take It with Them



Make copies of the craft/take home sheets, if you are not already using them as one of your activities. You may also want to make copies of the story (see take-home version of each story included in Appendix C with the other take home resources) to have for parents to use with their children at home. There's a link on each craft/take home sheet to the story, if you don't make hard copies.

Store It



After your session is over, collect the resources and store them for future use. This curriculum can be used over and over for years to come.

Unit 11: The God Who Saves

UNIT OVERVIEW

We all have disobeyed God. We have all lost the wonderful special closeness with God that He meant for us to have with Him. No matter how hard we try, we can't ever be good enough to win back special closeness with God. No, we can't save ourselves, but God can. That's why He sent Jesus: to save us as a free gift from Him. Anyone who turns away from their sins and trusts in Jesus as their Savior, will receive His forgiveness. They will become His people, who know Him in their hearts by His Holy Spirit. And one day, God will take them to live with Him forever. This is the free gift God offers to you and me. God is so kind to us!

In this unit we will learn three truths about this wonderful, free gift God offers us.

UNIT BIBLE VERSE: Romans 6:23, ESV

"For the wages of sin is death, but the free gift of God is eternal life in Christ Jesus our Lord."

BIG QUESTION UNDER INVESTIGATION: How Can We Be Saved?

ANSWER: It Is God's Free Gift!

OPTIONAL Big Question 11 INTRODUCTION LESSON (Use Hide 'n' Seek Kids Unit 11 Material)

Story: The Case of the Most Important Question *Acts 16*

Bible Verse: Romans 6:23

BIBLE TRUTH 1: When We Tell God Our Sins and Turn Away from Them (3 Lessons Available)

Story: The Case of the Changed Climber *Luke 19:1-9*

Bible Verse: 1 John 1:8-9

➔ BIBLE TRUTH 2: When We Trust in Jesus as Our Own Savior (3 Lessons Available)

Story: The Case of the Amazed, Mad Man *Acts 8-9*

Bible Verse: Romans 10:9-10

BIBLE TRUTH 3: When the Holy Spirit Works in Our Hearts (3 Lessons Available)

Story: The Case of the Surprising, Second Birthday *John 3*

Bible Verse: Titus 3:5-7

Deep Down Detectives ESV Songs 11 Track Numbers

This is a listing of all songs mentioned in the unit curriculum. You may or may not choose to use all of the songs. They are listed in easy-reference order--NOT in the order used in the curriculum.

You may choose to simply burn a CD/load them onto an mp3 device in this order. Or, you may want to do what we do: choose the songs we want to use and create a play list of them in that order. Then, we burn a CD/upload the play list onto an mp3 device. A teacher only has to click forward to the next song, instead of hunting for the right track. The track number have been included as part of the title of each song, teachers will still have a reference to the track number listed in the curriculum (same as those listed below), even if you change the order on your customized play list.

SONGS USED EVERY UNIT OF THE CURRICULUM

- 1 The Classroom Song v.1
- 2 The Classroom Song v.2
- 3 The Classroom Song v.3
- 4 The Classroom Song v.4
- 5 Deep Down Detectives Theme Song
- 6 The Classroom Rules Song
- 7 Let's Pray Song
- 8 The Big Question Box Song
- 9 The Bible Chant Song
- 10 ACTS Prayer Song (Short Version)
- 11 ACTS Prayer Song (Full Version)

Why the Extra Songs?

Deep Down Detectives is a curriculum used by a wide age-span of kids. Sometimes one of the other songs is a better fit for your kids. Or, you may simply want to teach them more songs on the same Bible Truth. Use as many or as few as you want.

listen to or download songs for free at <https://praisefactory.org:Deep Down Detectives Music page>

Unit 11: The God Who Saves

- 12 Big Q & A 11 Song
- 13 Big Question 11 Song: How Can We Be Saved?
- 14 Big Question 11 Bible Verse Song: The Law of the Lord Psalm 19:7, ESV
- 15 *Extra Big Question 11 Bible Verse Song: The Law of the Lord Is Perfect Psalm 19:7, ESV (full version)*
- 16 *Extra Big Question 11 Bible Verse Song: The Law of the Lord Psalm 19:7, ESV (short version)*
- 17 Big Question 11 Hymn: Holy Bible, Book Divine
- 18 Big Question 11 Praise Song: The Best Book to Read Is the Bible

How Can We Be Saved?

God's Laws Are Perfect...

Bible Truth 1: When We Tell God Our Sins and Turn Away from Them

- 19 Bible Verse: Hear, O Israel Deuteronomy 5:1,7-21 , ESV (full version)
- 20 Bible Verse: Hear, O Israel Deuteronomy 5:1,7-21 , ESV (short version)

Bible Truth 2: When We Trust in Jesus as Our Own Savior

- 21 Bible Verse: By Works of the Law Romans 3:20-23, HCSB
- 22 *Extra Bible Verse: Now We Know Romans 3:19-24, ESV*
- 23 *Extra Bible Verse: For Christ Suffered Once for Sins 1 Peter 3:18, ESV*
- 24 *Extra Bible Verse: The Lord Looks Down Psalm 14:2-3, HCSB*
- 25 *Extra Bible Verse: All We Like Sheep Isaiah 53:6, ESV*
- 26 *Extra Bible Verse: Seek the Lord Isaiah 55:6-7, ESV*

Bible Truth 3: When the Holy Spirit Works in Our Hearts

- 27 Bible Verse: Love the Lord Matthew 22:37-40, ESV

Big Question 11, Bible Truth 2 Overview: Key Concepts

p.1

Unit 11: The God Who Saves

Unit Big Question (and Answer): How Can We Be Saved? It Is God's Free Gift!

Unit Bible Verse: "For the wages of sin is death, but the free gift of God is eternal life in Christ Jesus our Lord."
--- Romans 6:23, ESV

Bible Truth 2 Concept: It Is God's Free Gift... When We Trust in Jesus as Our Own Savior!

God created us to love and obey Him, but we have all chosen to disobey Him. That's why we all deserve His punishment, instead of His friendship. Our sins separate us from Him. God would be fair to punish us for our sins, but He has chosen to be so kind to us. He offers to forgive our sins and make us His people through Jesus, His Son.

Jesus came to earth and lived a perfect life. He never, ever disobeyed God. Then on the cross, Jesus chose to offer up His perfect life as the perfect sacrifice for the sins of God's people. He took the punishment for sins they deserved to save them from their sins.

Jesus died on the cross and was buried in a grave, but He didn't stay there. He had beaten sin and death for God's people. He rose from the dead in victory, never to die again! Now, all who turn away from their sins and trust in Jesus as their Savior, are forgiven their sins. They are God's people who know Him in their hearts by His Holy Spirit. And when they die, they will go to live perfectly happy with Him forever. This wonderful, free gift can be ours, too, when we turn away from our sins and trust in Jesus as our own Savior. Isn't that wonderful news!

Bible Truth 2 Bible Verse: Romans 10:9-10

"If you confess with your mouth that Jesus is Lord and believe in your heart that God raised him from the dead, you will be saved. For with the heart one believes and is justified, and with the mouth one confesses and is saved."

Learn a Little: "If you confess Jesus is Lord and believe that God raised him from the dead, you will be saved."

Meaning

To believe something in your heart is to think that something is true. To confess something is to tell others what you think is true. Christians are those who believe in their hearts that Jesus is the Son of God, who died on the cross to save God's people from their sins. They believe that He rose from the dead on the third day, showing that He had beaten sin and death for them. They love telling this good news to others that they might believe and be saved, too. We must believe in our own hearts that He is our Savior and be willing to confess to others that He is our Lord, if we are to be saved, too!

Bible Truth 2 ACTS Prayer

- A** God, we praise You for being good and just. We honor You as the One we should all obey.
- C** God, we confess that we are all sinners who have disobeyed You. We know that we can never deserve to be Your people by good things we do. We need a Savior!
- T** Thank You, God, for sending Jesus as the Savior we need. Thank You that He made the way for us to become Your people with His perfect life given as the full payment for the sins of God's people.
- S** God, work in our hearts. Help us to confess our sins to You and turn away from them. Help us to trust in Jesus as our Savior that we might become Your people. Help us to know and love You. Help us to live for You. In Jesus' name we pray, Amen.

Big Question 11, Bible Truth 2 Overview: Key Concepts

p.2

Bible Truth 2 Story

The Case of the Amazed, Mad Man Acts 8-9

Songs Used in Bible Truth 2 Songs Used in Bible Truth 2

Big Q & A 11 Song

Big Question 11 Song: How Can I Be Saved?

Big Question 11 Bible Verse Song: The Free Gift of God Is Eternal Life Romans 6:23, ESV

Big Question 11 Hymn: Grace Greater than All Our Sin, refrain

Big Question 11 Praise Song: Blessed Be the Name

Bible Truth 2 Bible Verse Song: If You Confess with Your Mouth Romans 10:9-10, ESV

Extra Bible Truth 2 Verse Song: In My Father's House John 14:2-6, ESV

listen to or download songs for free at <https://praisefactory.org>: Deep Down Detectives Music page

1. GETTING STARTED



= follow the stars for a short & simple lesson plan

<p>Intake Activity Ideas</p>	<p>Choose one of these open-ended activities to include children as they join the class:</p>
<p>Free Play Time <i>suggestions in Appendix D</i></p>	<p>★ Offer your own or some of the easy-to-make, free play activities suggested in Appendix D.</p>
<p>OR Sing-along Music Time <i>lyrics and sheet music, Appendix A</i> <i>listen to or download songs for free at https://praisefactory.org/DeepDownDetectivesMusicpage</i></p>	<p>Music from Deep Down Detectives (DDD) ESV Songs 11: Big Q & A 11 Song <i>DDD ESV Songs 11, track 12</i> Big Question 11 Song <i>DDD ESV Songs 11, track 13</i> Big Question 11 (Unit) Bible Verse Song: The Free Gift of God Is Eternal Life Romans 6:23, ESV <i>DDD ESV Songs 11, track 14</i> Big Question 11 Hymn: Grace Greater than All Our Sin, refrain <i>DDD ESV Songs 11, track 15</i> Big Question 11 Praise Song: Blessed Be the Name <i>DDD ESV Songs 11, track 16</i> Bible Truth 2 Bible Verse Song: If You Confess with Your Mouth Romans 10:9-10, ESV <i>DDD ESV Songs 11, track 19</i> Extra Bible Truth 2 Bible Verse Song: In My Father's House John 14:2-6, ESV <i>DDD ESV Songs 11, track 20</i></p> <p><i>Add more fun to Sing-along Music Time by adding a Music, Movement & Memory Activity. These activities are listed on p.10 of this lesson plan with the Response Activities. Instructions found in Appendix B.</i></p>
<p>OR Bible Verse Memory Game <i>instructions found in Appendix B</i></p>	<p>Lesson 1 Game: Loud and Soft, Big and Little Lesson 2 Game: Freeze 'n' Say Lesson 3 Game: Detective Mission Madness Practice</p> <p><i>These activities are also included on p.10 of this lesson plan with the Response Activities.</i></p>
<p>2. OPENING CIRCLE TIME (introduce the Bible Truth and tell the related Bible story)</p>	
<p>Gathering the Children <i>lyrics and sheet music, Appendix A</i></p>	<p><i>Sing verse 1 of The Classroom Song to gather the children for Circle Time.</i></p> <p>The Classroom Song, verse 1 <i>DDD ESV Songs 11, track 1</i> Let's gather together to worship God, Let's gather together to worship God, Let's gather together to worship God, Come gather here with me!</p> <p>"</p>
<p>Welcome to Deep Down Detectives</p>	<p>★ Welcome to Deep Down Detectives. We're so glad you've joined us! Detectives are people who look for answers to questions. In Deep Down Detectives, we look for answers to big questions about God. We dig deep down in the truths of God's Word to find them."</p>

2. OPENING CIRCLE TIME, continued



= follow the stars for a short & simple lesson plan

<p>Deep Down Detectives Theme Song</p> <p><i>lyrics and sheet music, Appendix A</i></p>	<p>"Let's sing our Deep Down Detectives Theme Song."</p> <p>Deep Down Detectives Theme Song Deep Down Detectives Theme Song <i>DDD ESV Songs 11, track 5</i></p> <p>We're Deep Down Detectives, diggin' deep in God's Word, For truths about God and His plans for this world, We're seeking to love Him, with all of our heart, We're Deep Down Detectives! Come on! Let's start!</p>
<p>Classroom Rules Song</p> <p><i>lyrics and sheet music, Appendix A</i></p>	<p>There are two very important things that Deep Down Detectives do together: we worship God and we love one another. Our Classroom Rules Song reminds us how we should act. Let's sing it."</p> <p>Classroom Rules Song <i>DDD ESV Songs 11, track 6</i></p> <p>Shh, be quiet while someone is talking, Raise your hand, if you have something to say, Don't touch your friend, sitting beside you, Obey your teachers, Be kind as you play. These are our classroom rules, These are our classroom rules, They help us worship God and love one another, These are our classroom rules.</p>
<p>Opening Prayer Time</p> <p><i>lyrics and sheet music, Appendix A</i></p>	<p>"Children, we need God's help to keep these rules. Let's ask Him to help us right now. Let's get ready and pray."</p> <p>Let's Pray <i>DDD ESV Songs 11, track 7</i></p> <p>1-2-3! Fold your hands, Bow your head, Close your eyes. Let's pray! (<i>repeat</i>)</p> <p>"Let's pray:"</p> <p>Opening Prayer </p> <p>Dear Lord, We're so glad to get to gather together to worship You! Please help us keep the classroom rules. Please help us to love You and learn about You today. In Jesus' name we pray. Amen.</p>

2. OPENING CIRCLE TIME, continued

★ = follow the stars for a short & simple lesson plan

Reveal the Big Question
Introduce the Big Question Box/Briefcase

lyrics and sheet music, Appendix A

“Detectives INVESTIGATE things. That means they ask questions and look for answers. Deep Down Detectives investigate big questions about God. The Big Question we are investigating today is right inside our Big Question Box/Briefcase.

The Big Question Box Song

DDD ESV Songs 11, track 8

We’ve got a big box,
All closed up and locked,
Filled with the truths of God’s Word.

We’ve got a brief case,
There’s no time to waste,
Come on, kids, let’s open it up!

The Big Question under Investigation

VISUAL take out AID



of BQB

Big Question & Answer Sign, front side

**found in the DDD Unit 11 Visual Aids, ESV Book*

Ok, who would like to open for me and pull out the Big Question?”

Choose a child to open the box/briefcase, take out the Big Question and hand it to you, then hold up the Big Question sign for all the children to see, and say:

★ The Big Question we are investigating today is Big Question Number 11:

How Can We Be Saved?

and the Answer is:

It Is God’s Free Gift!

Big Question Meaning

★ We all have disobeyed God. We have all lost the wonderful special closeness with God that He meant for us to have with Him. No matter how hard we try, we can’t ever be good enough to win back special closeness with God.

No, we can’t save ourselves, but God can. That’s why He sent Jesus: to save us as a free gift from Him. Anyone who says “sorry” to God for their sins and trusts in Jesus as their Savior, He will forgive all their sins. God will give them special closeness with Himself right now. Then one day, He will take them to live with Him forever. This is the free gift God offers to you and me. God is so kind to us!

Big Question Songs

★ “Let’s sing our Big Question Song:

Big Q & A 11 Song

Big Q & A 11 Song

DDD ESV Songs 11, track 12

(adapted version of “Here We Go Looby-Loo”)

lyrics and sheet music, Appendix A

How can we be saved?
How can we be saved?
How can we be saved?
It is God’s free gift!

2. OPENING CIRCLE TIME, continued



= follow the stars for a short & simple lesson plan

<p>Learning about the Big Question (use one or both)</p> <p>★</p>	<p>Repeat the Big Question and Answer again: "How Can We Be Saved? It Is God's Free Gift!"</p> <p>Say: "Hmmm, I wonder what that means... Let's do our action rhyme/sing our song that explains it."</p> <p>Then do the action rhyme or sing the song using any of the optional motions suggested, if desired.</p>	
<p>Big Question Action Rhyme</p>	<p>Big Question 11 Action Rhyme</p> <p>I disobey God, I need a Savior! You disobey God, You need a Savior! We all disobey God, We all need a Savior! Oh, what a sad, sad day!</p> <p>But... God has a wonderful, free gift for me! A wonderful, free gift for you! God has a wonderful, free gift for us all. God will forgive our sins through Jesus! Oh, what a happy, happy day!</p>	<p>(POSSIBLE ACTIONS)</p> <p><i>Point to self</i> <i>Point out to others</i></p> <p><i>extend arms out wide to each side</i> <i>make a sad face</i></p> <p><i>Point to self</i> <i>Point out to others</i></p> <p><i>extend arms out wide to each side</i> <i>cheer and jump up and down for this best of news</i></p>
<p>Big Question (Action Rhyme) Song</p> <p>★</p> <p><i>lyrics and sheet music, Appendix A</i></p>	<p>Big Question 11 Action Rhyme/ Song</p> <p>Refrain</p> <p>How can we be saved? How can we be saved? How can we be saved? It's God' free gift. How can we be saved? How can we be saved? How can we be saved? It's God's free gift through Christ.</p> <p>Verse 1</p> <p>I disobey God, I need a Savior, You disobey God, You need a Savior, We all disobey God, We need a Savior. To save us from our sins. <i>Refrain</i></p> <p>Verse 2</p> <p>Jesus, He paid the price, the perfect sacrifice, On the cross, gave His life, Bought us eternal life, Takes away all our sin, Makes our hearts clean within, When we repent and believe in Him. <i>Refrain</i></p>	<p style="text-align: right;"><i>DDD ESV Songs 11, track 13</i></p> <p>(POSSIBLE ACTIONS)</p> <p><i>point up to God in heaven</i></p> <p><i>Point to self</i> <i>Point out to others</i></p> <p><i>extend arms out wide to each side</i></p> <p><i>make a cross with your index fingers</i></p> <p><i>Touch heart</i> <i>Make prayer hands and bow head</i></p>

2. OPENING CIRCLE TIME, continued

★ = follow the stars for a short & simple lesson plan

Learning the Bible Truth

VISUAL take out
AID



of BQB

VISUAL AID

All the Bible Truths Sign

★ "It is God's free gift" is a good beginning, but there's so more to learn. So it's time for us to dig down even deeper for more answers to our Big Question about God. We're going to be learning **THREE** Bible truths that all tell us more about this wonderful, free gift God offers us.

Who would like to hand me the picture with our three Bible truths on it? It's in the Big Question Box/Briefcase." *Choose a child to get it and hand it to you, then hold it up and show them the pictures of the three truths they will be learning.*

Bible Truth Clue

VISUAL take out
AID



of BQB

Bible Truth Clue Sign,
front side
VISUAL AID

After everyone has had a good look, say...

"Ok, we've learned one truth about God's free gift of salvation. It's this one: "When We Tell God Our Sins and Turn Away from Them." (point to picture as you identify the Bible Truth). Now let's look at our Bible Truth Clue sign and see if we can figure out which of these three truths we will be learning about today. Who would like to get it out of the Big Question Briefcase for me?"

Choose a child to open the briefcase, take out the Bible Truth Clue sign and hand it to you. Hold up the front side for the children to see. Cover up the answer, written along the bottom, and say:

**"How Can We Be Saved?
It Is God's Free Gift!
When We Trust in ???? As Our Own Savior!"**

Hint

We're missing one word. Here's the hint to what the missing word is. It says: "What's the name of God's Son? His name starts with a "J" and it sounds like "sneezes."

Can you guess? It's "JESUS."

So the Bible Truth we are learning today is:
(uncover answer from bottom of sign, show it to them and say:)

★ **"How Can We Be Saved?
It Is God's Free Gift!
When We Trust in JESUS As Our Own Savior!"**

Bible Truth Meaning

★ And here is what this Bible Truth means: *(read the meaning off of the back of the sign, say:)*

God created us to love and obey Him, but we have all chosen to disobey Him. That's why we all deserve His punishment, instead of His friendship. Our sins separate us from Him. God would be fair to punish us for our sins, but He has chosen to be so kind to us. He offers to forgive our sins and make us His people through Jesus, His Son.

Jesus came to earth and lived a perfect life. He never, ever disobeyed God. Then on the cross, Jesus chose to offer up His perfect life as the perfect sacrifice for the sins of God's people. He took the punishment for sins they deserved to save them from their sins.

Jesus died on the cross and was buried in a grave, but He didn't stay there. He had beaten sin and death for God's people. He rose from the dead in victory, never to die again! Now, all who turn away from their sins and trust in Jesus as their Savior, are forgiven their sins. They are God's people who know Him in their hearts by His Holy Spirit. And when they die, they will go to live perfectly happy with Him forever. This wonderful, free gift can be ours, too, when we turn away from our sins and trust in Jesus as our own Savior. Isn't that wonderful news!

2. OPENING CIRCLE TIME, continued



= follow the stars for a short & simple lesson plan

Learning the Bible Verse

"And how do I know this is true? God tells me so in His special book, the Bible."

The Bible Chant Song

Say or sing the Bible Chant Song.

lyrics and sheet music, Appendix A

The Bible Chant Song

DDD NIV Songs 11, track 9

The Bible, the Bible,
Let's get out the Bible.
Let's hear what God has to say.
The Bible, the Bible,
God's given us the Bible.
It's His Word for us to learn and obey! Yay!

Bible Verse

DDD 11.2 Bible Verse-front side (in the DDD Bible folder)

VISUAL AID Place verse in take out



*found in the DDD Unit 11 Visual Aids, ESV Book

"Who would like to get our Bible folder out of the Big Question Briefcase for me?"

Choose a child to open the briefcase, take out the "Bible" folder and hand it to you. Remove the Bible Verse Picture from the "Bible" folder and hold it up for all the children to see, then say:

"Who would like to get our Bible folder out of the Big Question Briefcase for me?"

Choose a child to open the briefcase, take out the "Bible" folder and hand it to you. Remove the Bible Verse Picture from the "Bible" folder and hold it up for all the children to see, then say:

Romans 10:9-10 tells us:



Romans 10:9-10, ESV

"If you confess with your mouth that Jesus is Lord and believe in your heart that God raised him from the dead, you will be saved. For with the heart one believes and is justified, and with the mouth one confesses and is saved."

Learn a Little: "If you confess Jesus is Lord and believe that God raised him from the dead, you will be saved."

Bible Verse Meaning



What does that mean?

To believe something in your heart is to think that something is true. To confess something to others is to tell them what you think is true. Christians are those who believe in their hearts that Jesus is the Son of God, who died on the cross to save God's people from their sins. They believe that He rose from the dead on the third day, showing that He had beaten sin and death for them. They love telling this good news to others that they might believe and be saved, too.

We must believe in our own hearts that He is our Savior and be willing to confess to others that He is our Lord, if we are to be saved, too!

2. OPENING CIRCLE TIME, continued

★ = follow the stars for a short & simple lesson plan

**Bible Verse
Song**

*lyrics and sheet music,
Appendix A*

You might also enjoy:

*In My Father's House
John 14:2-6, NIV 1984
DDD ESV Songs 11, track 20*

We've said our Bible verse, now let's sing it!

If You Confess with Your Mouth: Romans 10:9-10

DDD ESV Songs 11, track 19

If you confess, with your mouth, "Jesus is Lord,"
And believe in your heart,
That God raised Him from the dead,
You will be saved, you will be saved.
For with the heart, one believes and is justified.

If you confess, with your mouth, "Jesus is Lord,"
And believe in your heart,
That God raised Him from the dead,
You will be saved, you will be saved.
For with the mouth, one confesses and is saved.
Romans Ten: nine through ten.

2. OPENING CIRCLE TIME, continued



= follow the stars for a short & simple lesson plan

<p>Getting into the Case</p>	<p>"Now it's time to do a bit more deep down investigating. Let's see what Detective Dan wants us to help him figure out. Would someone like to get it out for me?"</p>
<p>Listening Assignments</p> <p>Place in  take out  of BQB</p>	<p>NOTE: Listening assignments are most suitable for ages 3+. Skip straight to the Bible story (see bottom of this page), if working with 2 year olds.</p> <p>"Let's open up our listening assignment and see what we are supposed to figure out today.</p> <p>Choose a child to take out the Listening Assignment (from the DDD Bible Folder) and hand it to you. Read Detective Dan's letter to the children that includes the listening assignment. The listening assignments are summarized below:</p>
<p>VISUAL AID</p> <p></p> <p>DDD Unit 11 Visual Aids, ESV</p>	<p>Detective Dan's Lesson #1 Listening Assignment:</p> <p>I need to know:</p> <ol style="list-style-type: none"> 1. Who was the man who was so mad? What was he so mad about? 2. What amazing thing happened to him? How did he change when it happened?
<p>VISUAL AID</p> <p></p> <p>DDD Unit 11 Visual Aids, ESV</p>	<p>Detective Dan's Lesson #2 Listening Assignment:</p> <p>Our Bible Verse is Romans 10:9-10, ESV</p> <p>"If you confess with your mouth that Jesus is Lord and believe in your heart that God raised him from the dead, you will be saved. For with the heart one believes and is justified, and with the mouth one confesses and is saved."</p> <p>I need to know:</p> <ol style="list-style-type: none"> 1. Who told people to stop saying Jesus is the Savior? 2. Why did he change his mind?
<p>VISUAL AID</p> <p></p> <p>*Listening Assignment #3 includes the Assignment Sheet, plus 6 clue pictures*</p> <p>DDD Unit 11 Visual Aids, ESV</p>	<p>Detective Dan's Lesson #3 Listening Assignment:</p> <p>I found six clues, but two of them are NOT in the story. They are: a barrel, a soldier, a jail, an apple, a high priest, and a bright light. Hold each of them up for the children to see as you identify them.</p> <p>I need to know:</p> <ol style="list-style-type: none"> 1. Which four belong in the story and which two don't? 2. What surprising person praised Jesus for being God's Son, the Savior? did the bad, bad, bad man pray that pleased God? What did God do for this man?
<p>Tell the Bible Story</p> <p>Place story & pics in  take out  of BQB</p> <p>DDD Unit 11 Visual Aids, ESV</p> <p>Story text included in this book right after this lesson plan and in Visual Aids book</p>	<p>Then say, "Ok, Deep Down Detectives! Put on your best listening ears and see if you can hear the answers to Detective Dan's questions. When I finish telling the story, we will see if we can answer all the questions."</p> <p>Bible Story: The Case of the Amazed, Mad Man</p> <p>Acts 8-9</p> <p>Read the Bible Truth story, putting up the storyboard pictures as you tell it. Then, have the children answer the listening assignment. Present the gospel and lead in prayer.</p> <p>*Answers to questions; the gospel; and, ACTS prayer are included with the story text.*</p>

Lesson Plan: Big Question 11, Bible Truth 2

use with all THREE lessons

2. OPENING CIRCLE TIME, continued

★ = follow the stars for a short & simple lesson plan

<p>Story Response Song(s)</p> <p>Hymn</p> <p><i>lyrics and sheet music, Appendix A</i></p>	<p><i>As attention span and time allow, you might want to end with one of the following songs which also tie in with the unit. If desired, use the Music and Movement activity ideas while singing, listed with the Response Activities.</i></p> <p>Grace that Is Greater than All Our Sin <i>DDD ESV Songs 11, track 15</i></p> <p>Verse 1 Grace, grace, God's grace, Grace that will pardon and cleanse within; Grace, grace, God's grace, Grace that is greater than all our sin.</p> <p>Tie-in: "Children do you know what the word "grace" means? It means a free gift that we don't deserve! And what grace--what free gift-- does God offer us through Jesus? To forgive us and save us from the punishment we deserve for disobeying God! Let's sing of God's marvelous grace!"</p>
--	---





<p>Praise Song</p> <p><i>lyrics and sheet music, Appendix A</i></p>	<p>Praise Song: Blessed Be the Name <i>DDD ESV Songs 11, track 16</i></p> <p>All praise to Him who reigns above, In majesty supreme. Who gave His Son for man to die, That He might man redeem!</p> <p>Tie-in: "How can we be saved? It is God's free gift through the Lord Jesus! There would be no hope for us, if God did not send Jesus to be our Savior. That's why God's people love to bless His name. They are so grateful that He paid for their sins so that they can know God and live with Him forever!"</p>
--	--

3. TAKING ACTION: Response Activities *(choose from among these activities)*

<p>Transition to Activities</p>	<p>★ Well, Deep Down Detectives, you've done a great job diggin' deep down for answers in the truths of God's Word. Now it's time to enjoy some activities."</p> <p><i>Tell children what activity/s you are providing for them: eTher free play or some of the response activities listed below. When you are ready to dismiss them, use this song to help the children transition in an orderly fashion to their next activity.</i></p> <p>"Children, let's sing our Time to Play Song. When we are finished you may get up and walk over to our next activity."</p>
--	--

<p>Classroom Song, verse 2</p> <p><i>lyrics and sheet music, Appendix A</i></p>	<p>Classroom Song, verse 2 <i>DDD ESV Songs 11, track 2</i></p> <p>We've gathered together to worship God, We've gathered together to worship God, And now it's time to play.</p> <p><i>Dismiss the children to whatever activities you have prepared for them to do.</i></p>
--	---

3. TAKING ACTION: Response Activities (choose from among these activities) ★ = short & simple lesson plan

<p>Response Activities</p>	<p>Choose one or more activities appropriate for your children, based on classroom time and developmental needs. Add the Discussion Sheet to any activity for deeper learning. ★</p>
<p>Bible Verse Memory Game <i>game directions, Appendix B</i></p>	<p>Though listed with the opening activities, you may choose to use this Bible verse game here instead (or as a repeat).</p> <ul style="list-style-type: none"> • Lesson 1 Game: Loud and Soft, Big and Little • Lesson 2 Game: Freeze 'n' Say • Lesson 3 Game: Detective Mission Madness Practice <p>Use the Discussion Sheet with this activity for even deeper learning ★</p>  <p>Discussion Questions</p>
<p>Music, Movement & Memory Activity <i>game directions, Appendix B</i></p>	<p>A music activity that uses the songs from the Bible Truth and Big Question unit.</p> <ul style="list-style-type: none"> • DDD Songs for this Bible Truth, plus: • Lesson 1 Activity: Sing, Dance and Fall Down • Lesson 2 Activity: Bottle Shakers • Lesson 3 Activity: March 'n' Say <p>Use the Discussion Sheet with this activity for even deeper learning ★</p>  <p>Discussion Questions</p>
<p>Bible Story Review Game <i>game directions, Appendix B</i></p>	<p>A game that uses the storyboard pictures from the story to review the story.</p> <ul style="list-style-type: none"> • Lesson 1 Game: Going Fishing • Lesson 2 Game: Pony Express • Lesson 3 Game: Who's Inside? <p>Use the Discussion Sheet with this activity for even deeper learning ★</p>  <p>Discussion Questions</p>
<p>Coloring Pages/ Take Home Sheets <i>in Appendix C</i></p> <p>★</p>	<p>A coloring page related to the lesson assignment question is provided for each lesson. On the back of each are the key concepts, a few questions and a song for parents to use with their children.</p> <p>NOTE: Upgrade your coloring sheet to a more interesting craft by offering simple embellishments, such as jiggly eyes, craft sand, glitter, glitter glue, colored paper dots (made with a hole punch), fabric scraps, etc. Make cut-to-size glued-on clothes, hair, etc for characters by using a copy of the coloring sheet, cutting out the selected portions and making them the patterns for whatever you want to cut out of fabric, paper, foil, etc.</p> <ul style="list-style-type: none"> • Lesson 1 Coloring Sheet Emphasis: Bible Truth • Lesson 2 Coloring Sheet Emphasis: Bible Verse • Lesson 3 Coloring Sheet Emphasis: ACTS Prayer <p>Use the Discussion Sheet with this activity for even deeper learning ★</p>  <p>Discussion Questions</p>
<p>Extra Crafts: Big Question Craft <i>in Appendix C</i></p> <p>Bible Verse Craft <i>in Appendix C</i></p> <p>Bible Story Puzzle <i>in Appendix C</i></p>	<p>These crafts are slightly more complex than the coloring/take home sheets:</p> <p>The Bible Concept Go-and-Tell Craft is a craft that summarizes the Bible concept and includes the Bible verse is included for those desiring more than a coloring sheet. This more complex craft will involve gluing, sticking, etc. Can be used at any time.</p> <p>The Bible Story Coloring Sheet provides a tie in between the Bible story and the Bible truth they are learning.</p> <p>The Storyboard Picture Placement Page has been made into a puzzle that can be cut out and re-assembled by the children. This provides a nice summary of the story.</p> <p>Use the Discussion Sheet with these activities for even deeper learning ★</p>  <p>Discussion Questions</p>
<p>Free Play Activities ★ <i>ideas in Appendix D</i></p>	<p>Offer your own or some of the easy-to-make, free play activities suggested in Appendix D.</p>

4. CLOSING CIRCLE TIME *(End-of-session activities for the last 5-10 minutes of class time)*

 = short & simple lesson plan

<p>Transition to Closing Circle</p> <p>Classroom Song, verse 3</p> <p><i>lyrics and sheet music, Appendix A</i></p>	<p><i>Use this song to help the children transition in an orderly fashion. Start singing this song and ask the children to gather with you for Closing Circle Time.</i></p> <p>Classroom Song, verse 3 <i>DDD ESV Songs 11, track 3</i></p> <p>It's time to get ready to go and tell, It's time to get ready to go and tell, Come gather here with me.</p>
<p>Closing Circle Time</p> <p>Classroom Song, verse 4</p> <p><i>lyrics and sheet music, Appendix A</i></p>	<p><i>When children are settled in the circle, say:</i></p> <p>"It's almost time for your parents to come pick you up. And do you know what that means? It means.... (draw this out to build anticipation and excitement)...that it's almost time to go home and....it's almost time to...Go and Tell! We have learned some big news about God today. God wants us to take and tell it to the whole world!"</p> <p>Classroom Song, verse 4 <i>DDD ESV Songs 11, track 4</i></p> <p>So what's our big news to go and tell, So what's our big news to go and tell, Can you tell me now?</p>
<p>Big News to Tell</p> <p>Big Question 11</p> <p><i>VISUAL AID</i></p> <div style="border: 1px solid black; background-color: #90EE90; padding: 5px; display: inline-block; margin: 5px 0;">#1</div> <p><i>*found in DDD Unit 11 Visual Aids, ESV Book lyrics and sheet music, Appendix A</i></p> <p>Big Question 11, Bible Truth 2</p> <p><i>VISUAL AID</i></p> <div style="border: 1px solid black; background-color: #90EE90; padding: 5px; display: inline-block; margin: 5px 0;">#3</div>	<p>"Let's see....there's so much big news to tell! There's so much we've learned!</p> <p>First of all, can you tell me the answer to our Big Question: "How Can We Be Saved?" <i>Hold up the Bible Truth Clue Picture.</i></p> <p>Say the answer with me: "It Is God's Free Gift!"</p> <p><i>(If desired, you can sing one/both of the Big Question songs.)</i> <i>DDD ESV Songs 11, tracks 12,13</i></p> <p>And what's one way He does this? What did we learn? <i>Point to the picture.</i></p> <p>When We Trust in Jesus as Our Own Savior!</p> <p>"And how do I know this is true? Can you tell me? Say it with me: "The Bible tells me so!" That's right!</p>
<p>Big Question 11, Bible Truth 2 Bible Verse</p> <p><i>VISUAL AID</i></p> <div style="border: 1px solid black; background-color: #90EE90; padding: 5px; display: inline-block; margin: 5px 0;">#4</div> <p><i>*found in the DDD Unit 11 Visual Aids, ESV Book lyrics and sheet music, Appendix A</i></p>	<p>We learned: Romans 10:9-10, ESV:</p> <p>"If you confess with your mouth that Jesus is Lord and believe in your heart that God raised him from the dead, you will be saved. For with the heart one believes and is justified, and with the mouth one confesses and is saved."</p> <p>Learn a Little: "If you confess Jesus is Lord and believe that God raised him from the dead, you will be saved."</p> <p>What does that mean?</p> <p>To believe something in your heart is to think that something is true. To confess something is to others is to tell them what you think is true. Christians are those who believe in their hearts that Jesus is the Son of God, who died on the cross to save God's people from their sins. They believe that He rose from the dead on the third day, showing that He had beaten sin and death for them. They love telling this good news to others that they might believe and be saved, too. We must believe in our own hearts that He is our Savior and be willing to confess to others that He is our Lord, if we are to be saved!</p> <p><i>(If desired, you can sing the Bible verse song.)</i> <i>DDD ESV Songs 11, track 19</i></p>

4. CLOSING CIRCLE TIME, continued



= follow the stars for a short & simple lesson plan

<p>Closing ACTS Prayer Time</p> <p>ACTS Prayer Chant</p> <p><i>lyrics and sheet music, Appendix A</i></p>	<p><i>Let's ask God to help us to remember this and even tell others this good news. Let's get ready and pray our ACTS prayer.</i></p> <p><i>And what does ACTS mean? Let's sing/say our ACTS Prayer Chant!</i></p> <p>ACTS Prayer Chant Song <i>DDDESV Songs 11, tracks 10,11</i></p> <p>A, Adoration, God, we praise You! C, Confession, Forgive us our sins. T, Thanksgiving, Thank You for Jesus, S, Supplication, Help us to live like Him.</p> <p style="text-align: right;">That's the ACTS prayer, my friend, Bow your head, Close your eyes, Shhh, Let's begin.</p>
<p>Closing ACTS Prayer</p>	<p>"Let's pray!"</p> <p><i>Lead the children in the ACTS prayer for this Bible Truth.</i></p> <p>A God, we praise You for being good and just. We honor You as the One we should all obey.</p> <p>C God, we confess that we are all sinners who have disobeyed You. We know that we can never deserve to be Your people by good things we do. We need a Savior!</p> <p>T Thank You, God, for sending Jesus as the Savior we need. Thank You that He made the way for us to become Your people with His perfect life given as the full payment for the sins of God's people.</p> <p>S God, work in our hearts. Help us to confess our sins to You and turn away from them. Help us to trust in Jesus as our Savior that we might become Your people. Help us to know and love You. Help us to live for You.</p> <p>In Jesus' name we pray, Amen.</p>
<p>5. TAKING IT HOME <i>(Take Home Sheet)</i></p>	
<p>Clean up and Dismissal </p>	<p>"Now it's time to work together and clean up." <i>Have the children join you in cleaning up the room.</i></p>
<p>Coloring Pages/ Take Home Sheets </p> <p><i>in Appendix C</i></p>	<p><i>Give out the craft/take home sheet and any other papers from the session, as you dismiss children from class.</i></p> <p><i>(Reminder: The back side of the coloring page is the take home sheet for each lesson.)</i></p>
<p>Bible Story to Take-Home</p> <p><i>in Appendix C</i></p>	<p>You may also want to include a copy of the story along with the take home sheet. (However, each coloring sheet/take home sheet includes a note to parents telling where they can download the story from the Parent Resources section on the website.</p>

The Case of the Amazed, Mad Man*Acts 8-9***Story-telling Tips**

Ahead of time:

1. Read the Bible verses and story. Pray!
2. Choose story action cues and prepare storyboard figures/Story Scenes, if using. (In Visual Aids book)
3. Practice telling story with the storyboard figures/Story Scenes, timing your presentation. Shorten, if necessary.

During your presentation:

1. Maintain as much eye contact as possible as you tell the story.
2. Put up storyboard figures/add story action cues/hold up Story Scenes as you tell the story. Allow the children to help you put them on the board, if desired.
3. Include the children in your story with a few questions about what they think will happen or words/concepts that might be new to them.
4. Watch the kids for signs that their attention span has been reached. Shorten, if necessary.

INTRODUCTION/ LISTENING ASSIGNMENTS

"Our story is called: The Case of the Amazed, Mad Man. Here is your listening assignment." Read from Detective Dan's Listening Assignment signs, but questions are summarized below:

Detective Dan's Lesson #1 Listening Assignment:

I need to know:

1. **Who was the man who was so mad? What was he so mad about?**
2. **What amazing thing happened to him? How did he change when it happened?**

Detective Dan's Lesson #2 Listening Assignment:**Our Bible Verse is Romans 10:9-10, ESV**

"If you confess with your mouth that Jesus is Lord and believe in your heart that God raised him from the dead, you will be saved. For with the heart one believes and is justified, and with the mouth one confesses and is saved."

I need to know:

1. **Who told people to stop saying Jesus is the Savior?**
2. **Why did he change his mind?**

Detective Dan's Lesson #3 Listening Assignment:I found six clues, but two of them are **NOT** in the story.

They are: a barrel, a soldier, a jail, an apple, a high priest, and a bright light.

Hold each of them up for the children to see as you identify them.

I need to know:

1. **Which four belong in the story and which two don't?**
2. **What surprising person praised Jesus for being God's Son, the Savior?**

Read the assignment questions, THEN SAY,

"Ok, Deep Down Detectives! Put on your best listening ears and see if you can hear the answers to Detective Dan's questions. When I finish telling the story, we will see if we can answer all the questions."

Read the Bible Truth story, answer questions, present the gospel and lead in prayer.

Answers to questions; the gospel; and, ACTS prayer are included with the story text.

The Case of the Amazed, Mad Man Acts 8-9*Story with lines separating paragraphs (text in bold, optional interaction cues in italics)*

Jesus' followers had good news to tell the people of Jerusalem: "Jesus is God's Son. He died on the cross to pay for the sins of God's people. On Day Three, He rose from the dead, beating sin and death for them," they said. "Turn away from disobeying God. Trust in Jesus as your Savior, and God will forgive your sins. You will be saved!" they exclaimed. "You can become one of God's people, too," they told everyone.

Many people in Jerusalem listened, and they believed. They turned away from their sins and trusted in Jesus as their own Savior. God forgave their sins and saved them. How happy they were to become God's people!

But some people listened to Jesus' friends and they were NOT happy. They were mad. Saul was one of those mad people. He HATED people who believed in Jesus.

"Be quiet! Stop saying Jesus is God's Son! Stop saying He died on the cross for the sins of God's people and rose from the dead! Stop saying He's the Savior," Saul told Jesus' followers. "Jesus is just a fake!" he exclaimed. "You are all wrong. And if you don't stop telling people about Jesus, I'm going to have you hurt and put you in jail," he warned them. Oh, no! What would Jesus' followers do now?

What do you think they did? Did they stop telling others about Jesus?

But no matter what Saul said, Jesus' followers didn't stop. They kept spreading the good news of Jesus. They kept urging everyone to turn away from their sins and trust in Him as their Savior. Uh, oh! NOW, what would Saul do?

What do you think he did?

Saul did exactly what he said he would do. He went from house to house with soldiers to arrest them. "Bang, bang, bang!" they knocked on the door. "Open up!" Saul and the soldiers dragged Jesus' followers out of their houses. They hurt them and put them in jail.

Saul kept making it hard to tell the good news of Jesus in Jerusalem, but even this was part of God's plan. "Jesus told us to tell the whole world about Him," Jesus' followers remembered. "Now it's time to go. A few of us will stay here in Jerusalem, but everyone else should move away to other cities," they decided. "People in those cities need to hear the good news of Jesus, too."

So, they packed up their things and moved to other cities. Some went to nearby cities. Others went to faraway cities. But wherever they went, they told everyone the gospel, the good news of Jesus.

Can you tell me the gospel, the good news about Jesus?

"Jesus is God's Son. He died on the cross to pay for the sins of God's people," they told everyone. "Then, on the third day, Jesus rose from the dead. He beat sin and death for God's people!" they explained. "So, turn away from your sins! Trust in Jesus as your Savior! God will forgive your sins and make you one of His people, too. You will be saved!" they exclaimed.

Story with lines separating paragraphs (text in bold, optional interaction cues in italics)

What good news this was! Many people in these cities listened and received the gospel with joy. They turned away from their sins and trusted in Jesus as their Savior. How happy Jesus' followers were to see the people in these new cities believing in Jesus, too!

But there was someone who was very angry when he heard about this. Can you guess who it was?

Can you guess?

It was Saul! He heard what was going on and he was furious! "I will stop these Christians," he vowed. So, Saul went to the high priest, the leader of Jesus' enemies, and said, "If you give me men to go to these other cities, I will arrest the Christians. I will bring them back to Jerusalem and put them in jail. I will stop them," Saul promised.

The high priest agreed. He gave Saul men to help him arrest the Christians in these other cities. Saul was pleased.

"March, march, march!" Saul and the men headed straight for the first city: Damascus. Saul could hardly wait to arrest those Christians and put them in jail! Now, he would stop all this talk about Jesus... or would he?

What do you think happened to Saul next?

Well, as it turned out, God, Himself, had very, very different plans for Saul. God was about change Saul's life completely. He would use Saul to spread the gospel, not stop it. Saul believed Jesus was a fake; but, of course, He wasn't. Jesus was the REAL Son of God. He really died on the cross and rose from the dead, beating sin and death for God's people.

And now, God was going to give Saul the gift of faith in Jesus. He would make Saul one of His people, then use Saul to spread the good news to many. Aren't God's plans amazing?

But how would Saul, a man who HATED Jesus and His followers, change into someone who trusted Jesus as his own Savior? God chose to change Saul in a most amazing way.

Just as Saul and the men were almost to Damascus, a light from heaven, much brighter than the sun, suddenly shone down on them. Saul shut his eyes tight and he fell to the ground. Then, he heard a voice saying to him, "Saul, Saul, why are you hurting me?"

Who are you, Lord?" Saul asked.

Who are you, Lord?" Saul asked. "I am Jesus, whom you are hurting," Jesus told Saul. "But get up now and go to Damascus and you will be told what to do."

The men with Saul stood there speechless; they heard the voice, but didn't see anyone. The bright, heavenly light vanished as quickly as it came, but not without leaving Saul with a problem. When he stood up and went to open his eyes, he couldn't see anything. Saul was blind!

Story with lines separating paragraphs (text in bold, optional interaction cues in italics)

The men took Saul by hand the rest of the way to Judas' house in Damascus. For three days, Saul didn't eat or drink. He just prayed and thought about everything Jesus said. Now, Saul knew the truth. He thought Jesus was a fake, and His believers were wrong. Now, Saul knew HE was the one who was wrong. Jesus WAS the Savior. He WAS God's Son. And Jesus' followers, they were GOD'S people!

Oh my! He had been hurting God's people! Saul knew he deserved God's punishment for all the terrible things he had done. But as Saul prayed, he asked God for more than he deserved. He asked for forgiveness. And what did God do? God helped Saul turn away from his sins and trust in Jesus as his own Savior. Saul was forgiven! He was saved! How kind God is to sinners like Saul, and like us!

Do you think God forgave Saul?

And sure enough, God gave Saul just what he prayed for. God helped Saul to turn away from disobeying God and to trust in Jesus as his own Savior. How kind God is to sinners like Saul...and like us!

After three days, God sent a Christian named Ananias to Saul. "Brother Saul, Jesus, who appeared to you, has sent me so you may see again and be filled with the Holy Spirit," he told Saul. Ananias laid his hands on Saul and something like scales fell off his eyes. God had healed him! But what happened next was even better: God's Holy Spirit came to live in Saul's heart.

Saul was so happy. God had saved him from his sins through Jesus. God had made Saul one of His people. Saul was a new man! Saul got up and was baptized as a sign that he was beginning a new life of living for God, with Jesus as his Savior. Then, Saul went out and did something else. Something he never, ever dreamed he would do. Can you guess what he did?

Can you guess?

Saul went out to tell the good news of Jesus to the people of Damascus. "Jesus is God's Son. He died on the cross to pay for the sins of God's people," Saul told them. "On the third day, He rose from the dead. He beat sin and death for God's people!" he exclaimed. "Turn away from disobeying God! Trust in Jesus as your Savior. God will forgive your sins and save you. You can be one of God's people!"

How surprised the people were! "Wasn't this the man who hated Jesus and His followers? Wasn't this the man who hurt them and put them in jail? And now HE is one of THEM!" they exclaimed. And as Saul preached about Jesus, the Holy Spirit worked in the hearts of many. They turned away from their sins and trusted in Jesus as their Savior.

Yes, all of God's good plans were coming true. His good plans for Saul and His good plans for the many others, who would trust in Jesus as their Savior through Saul's message. How amazing God is!

Cracking the Case: (story wrap-up for Listening Assignments)

It's time to see how we did with our Listening Assignment.

Detective Dan's Lesson #1 Listening Assignment:

1. Who was the man who was so mad? What was he so mad about? Saul. He was mad that Jesus' followers were telling people to trust in Jesus as their Savior.

2. What amazing thing happened to him? How did he change when it happened? Jesus appeared to Saul and Saul knew that He really was the Savior. Saul turned away from his sins and trusted in Jesus as his Savior. He started telling everyone the good news of Jesus.

For You and Me:

God turned Saul from a man who hated Jesus and wanted to hurt God's people, to someone who loved Jesus and served Him his whole life. God can work powerfully in our lives, too, when we turn away from our sins and trust in Jesus as our Savior.

Detective Dan's Lesson #2 Listening Assignment:**Our Bible Verse is Romans 10:9-10, ESV**

"If you confess with your mouth that Jesus is Lord and believe in your heart that God raised him from the dead, you will be saved. For with the heart one believes and is justified, and with the mouth one confesses and is saved."

I need to know:

1. Who told people to stop saying Jesus is the Savior? Saul did.

2. Why did he change his mind? Jesus appeared to Saul and Saul knew that He really was the Savior. Saul turned away from his sins and trusted in Jesus as his Savior.

For You and Me:

How amazing it is that God could change someone like Saul from a man who hated Jesus to a man who loved Him and trusted in Him as his Savior. God can change as to when we turn away from our sins and trust in Jesus as our Savior.

Detective Dan's Lesson #3 Listening Assignment:

I found six clues, but two of them are **NOT** in the story. They are: a drum, a Pharisee, a golden box, a sick man, the Temple, and a bag of money.

Hold each of them up for the children to see as you identify them.

I need to know:

1. Which four belong in the story and which two don't? The soldier, the jail, the high priest and the bright light belong. The barrel and the apple do not.

2. What surprising person praised Jesus for being God's Son, the Savior? What did God do for this man? Saul did. God showed him that Jesus really was the Son of God. He helped him to turn away from his sins and trust in Jesus as his Savior. God forgave his sins!

For You and Me:

Everyone was so surprised to see Saul change from a man who hated Jesus to a man who loved him and trusted in him as his Savior! God is able to change the heart of anyone! He's able to change our hearts to, ask him to change your heart! Ask him to help you turn away from your sins and trust in Jesus as your Savior. He loves to answer this prayer!

The Gospel (story wrap-up if NOT using Listening Assignments)**Our Bible Truth is:****How Can We Be Saved?****It Is God's Free Gift..****When We Trust in Jesus as Our Own Savior!**

How kind God was to save Saul! Saul had hated had hated God's people and he had hated the good news of Jesus. He had done terribly mean things. But, oh, how God had loved Saul anyway! He came to Saul in a special way. He worked in Saul's heart, helping him to turn away from disobeying God and trust in Jesus as His own Savior. God chose to have Jesus appear to Saul to help Saul believe in Him. He changed Saul's life and made him one of His people!

But God doesn't need to do such amazing things to change our hearts. If we ask Him, He will send the Holy Spirit to work in our hearts. He can help us to turn away from disobeying God and help us to trust in Jesus as our Savior. Then, we will be God's people, too.

Close in prayer.

Closing ACTS Prayer

- A** God, we praise You for being good and just. We honor You as the One we should all obey.
- C** God, we confess that we are all sinners who have disobeyed You. We know that we can never deserve to be Your people by good things we do. We need a Savior!
- T** Thank You, God, for sending Jesus as the Savior we need. Thank You that He made the way for us to become Your people with His perfect life given as the full payment for the sins of God's people.
- S** God, work in our hearts. Help us to confess our sins to You and turn away from them. Help us to trust in Jesus as our Savior that we might become Your people. Help us to know and love You. Help us to live for You.

In Jesus' name we pray, Amen.

Go to Lesson Plan, p.9 for the script to the rest of the lesson.

Deep Down Discussion Sheet

use with all THREE lessons

Use with all response activities for deeper learning



P.1

Questions to aid discussion of the key concepts and for use in games

Be familiar with these questions and answers. Look for opportunities to ask questions and discuss their answers, such as while the children work on their coloring pages, as part of their response games, or during play time. Remember: your goal isn't to ask all these questions or only talk to the children about these things. It is to be deliberate in having good conversations with them, however much or little you have.

<p>BIG QUESTION</p> <p>Meaning</p> <p>Discussion Questions</p>	<p>How Can We Be Saved? It Is God's Free Gift!</p> <p>We all have disobeyed God. We have all lost the wonderful special closeness with God that He meant for us to have with Him. No matter how hard we try, we can't ever be good enough to win back special closeness with God. No, we can't save ourselves, but God can. That's why He sent Jesus: to save us as a free gift from Him. Anyone who turns away from their sins and trusts in Jesus as their Savior, will receive His forgiveness. They will become His people, who know Him in their hearts by His Holy Spirit. And one day, God will take them to live with Him forever. This is the free gift God offers to you and me. God is so kind to us!</p> <p><i>choose a few</i></p> <ol style="list-style-type: none"> 1. How can we be saved? <i>It is God's free gift.</i> 2. Who has disobeyed God? <i>We all have.</i> 3. What happened to the special closeness with God that God created us to have? <i>We lost it because we are sinners.</i> 4. Can we ever be good enough to win back special closeness with God? <i>No, we cannot.</i> 5. Who did God send as a free gift to save us? <i>Jesus.</i> 6. What must we do to receive God's free gift of salvation? <i>Turn away from our sins and trust in Jesus as our Savior.</i> 7. What does God promise to all who do this? <i>Forgive their sins, and make Him their people. They will know them in their hearts now, by His Holy Spirit. Then, after their bodies die, He will bring them to live with Him, happy forever!</i>
<p>BIBLE TRUTH</p> <p>Meaning</p> <p>Discussion Questions</p>	<p>It Is God's Free Gift... When We Trust in Jesus as Our Own Savior!</p> <p>God created us to love and obey Him, but we have all chosen to disobey Him. That's why we all deserve His punishment, instead of His friendship. Our sins separate us from Him. God would be fair to punish us for our sins, but He has chosen to be so kind to us. He offers to forgive our sins and make us His people through Jesus, His Son.</p> <p>Jesus came to earth and lived a perfect life. He never, ever disobeyed God. Then on the cross, Jesus chose to offer up His perfect life as the perfect sacrifice for our sins. He took the punishment for sins we deserved to save us from our sins. Jesus died on the cross and was buried in a grave, but He didn't stay there. He had beaten sin and death for God's people. He rose from the dead in victory, never to die again! Now all who turn away from their sins and trust in Jesus as their Savior, are forgiven their sins. They are God's dearly-loved people who have special closeness with Him all the days of their lives. And when they die, they will go to live perfectly happy with Him forever. This wonderful, free gift can be ours, too, when we turn away from our sins and trust in Jesus as our own Savior. Isn't that wonderful news!</p> <p><i>choose a few</i></p> <ol style="list-style-type: none"> 1. God created us to do what? <i>To love and obey Him perfectly.</i> 2. Do we love and obey God perfectly? <i>No, we do not. We have all chosen to disobey Him.</i> 3. Do we deserve special closeness with God? <i>No.</i> 4. What do we deserve from God? <i>His punishment for our sins.</i> 5. What does God give His people that is better than they deserve? <i>He sent Jesus to take the punishment for their sins so that they could be saved.</i> 6. How can we become God's people and receive the free gift of salvation? <i>By turning away from our sins and trusting in Jesus as our Savior. God loves to answer this prayer!</i>

Deep Down Discussion Sheet

use with all THREE lessons

P.2

Questions to aid discussion of the key concepts and for use in games

THE GOSPEL	<p>What is God's good news for you and me? <i>The gospel! How Can We Be Saved? It Is God's Free Gift... When We Trust in Jesus as Our Own Savior. We all have broken God's good laws. We all deserve His punishment for our sins, and we know that we can never deserve His forgiveness. How sad! God would have been perfectly fair to give us all the punishment we deserve for breaking His laws. He is holy and good. But God is so rich in mercy. He chose to give us something better than we deserve. He sent His Son Jesus to live a perfect life. Yes! Jesus kept every, single one of God's laws! And on the cross, He suffered and died, giving His perfect life as the full payment for the sins of all who turn away from their sins and trust in Him as their Savior. On the third day, Jesus rose from the dead in victory, never to die again! Now, all who turn away from their sins and trust in Jesus as their Savior, are forgiven their sins. They are God's people who know Him in their hearts by His Holy Spirit. And when they die, they will go to live perfectly happy with Him forever. This wonderful, free gift can be ours, too, when we turn away from our sins and trust in Jesus as our own Savior. Isn't that wonderful news!</i></p>
<p>BIBLE TRUTH BIBLE VERSE</p> <p>Meaning</p> <p>Discussion Questions</p>	<p>"If you confess with your mouth that Jesus is Lord and believe in your heart that God raised him from the dead, you will be saved. For with the heart one believes and is justified, and with the mouth one confesses and is saved." --Romans 10:9-10, ESV</p> <p>Learn a Little: "If you confess Jesus is Lord and believe that God raised him from the dead, you will be saved."</p> <p>To believe something in your heart is to think that something is true. To confess something is to tell others what you think is true. Christians are those who believe in their hearts that Jesus is the Son of God, who died on the cross to save God's people from their sins. They believe that He rose from the dead on the third day, showing that He had beaten sin and death for them. They love telling this good news to others that they might believe and be saved, too. We must believe in our own hearts that He is our Savior and be willing to confess to others that He is our Lord, if we are to be saved, too!</p> <ol style="list-style-type: none"> 1. What does it mean to believe something in your heart? <i>To think that it is true.</i> 2. What does it mean to confess something? <i>To tell others what you think is true.</i> 3. Who do Christians believe in their heart is Lord? What does that mean? <i>They believe Jesus is Lord. They believe He is the Son of God who we should all obey.</i> 4. What amazing thing do they believe Jesus did? <i>He died on the cross for the sins of God's people and on the third day, God raised Him from the dead. He beat sin and death for God's people!</i> 5. How can Jesus become our Savior? <i>When we turn from our sins and trust in Him as our Savior.</i>
BIBLE STORY Discussion Questions	<p>The Case of the Amazed, Mad Man <i>choose a few</i></p> <ol style="list-style-type: none"> 1. What did Jesus' followers do that made Saul so mad? <i>They told everyone that Jesus died on the cross and rose from the dead to save God's people. They told everyone to turn away from their sins and trust in Jesus as their Savior.</i> 2. What did Saul tell Jesus' followers to do? <i>To stop telling people about Jesus.</i> 3. Why didn't Jesus' followers stop telling others about Jesus? <i>Because they wanted others to be forgiven their sins and know God.</i> 4. What did Saul do to Jesus' followers? <i>He found them, hurt them and had them put in jail.</i> 5. Why did Jesus' followers move to other cities? <i>So that Saul couldn't hurt them and so they could tell more people about Jesus.</i> 6. What happened to Saul when he went to Damascus to get rid of Jesus' followers who had moved there? <i>Jesus appeared to him on the road. He became blind and was taken to Damascus. He prayed, turned away from his sins and trusted in Jesus as his Savior.</i> 7. What did Saul start doing after he became a follower of Jesus? <i>He went around and told everyone the good news of Jesus, too.</i> 8. How can we be saved from our sins, like Saul was? <i>By turning away from our sins and trusting in Jesus as our Savior.</i>

DEEP DOWN DETECTIVES

**Curriculum Resources
for Unit 11, Bible Truth 3:**



How Can We Be Saved?

It Is God's Free Gift...

**When the Holy Spirit Works
in Our Hearts!**

Session Prep (especially good for newbies!)

Pray!



Pray for the Holy Spirit to be at work in your and the children's hearts.

Review



If new to the curriculum, look at the **Getting Started with Deep Down Detectives section of the Core Curriculum book.** (p.5) It will be especially helpful to read through the Deep Down Detectives section of **The Praise Factory Tour: Extended Version Book.** This is a visual way to understand what goes on in the classroom. (A pdf of the book is found in the samples section on the website.)

Look through and Learn the Lesson



Read over **lesson plan.** Practice any **songs or action rhymes** you are using. Choose/make up motions to go with these. Choose less with younger children and more with older preschoolers. **Practice the lesson with the visual aids** and using the Big Question Box/Briefcase.

Read and Rehearse the Bible Story with Pictures



Read the Bible story from the Bible. Read the curriculum version. Practice telling it with the storyboard pictures. (If you have not previously laminated the story pictures, do that now.) Or, rehearse it from the Simple Story Scenes, if you are using those.

Let There Be Music



Download the music and listen to the songs. Choose which of the songs you will use with the children. If using live musicians, make sure they have the sheet music (Appendix A, Core Curriculum book).

Put the Props in Place



1. Prepare your Visual Aids. Put the Big Question, Unit Bible Truths, Bible Truth, Bible Verse, and Listening Assignment signs, as well as the Bible Story script in one side of the Bible folder.
2. Get out your storyboard. If using Simple Story Scenes, put these in your Bible Folder. Or, if using the individual storyboard figures, put all background pictures in place (they have a BG by the number). Put the rest of the storyboard pictures (these have a SB by the number) in order of use in the other side of the Bible folder.
3. Put the DDD Bible Folder as well as the Big Question sign in the Big Question Box/Briefcase and shut it. If your box/briefcase has locks and you want to use the unlocking the box as part of your session, lock it now....but make sure you have the key or know the code first.
4. Prepare the music CD or sheet music or mp3 device for use in your session.

Set Out Free Play Activities



Choose and set up free time activities you will use with the children. Choose a variety of different activities that will be enjoyed by different types of children. Rotate the activities you provide to keep them interesting and fresh to your children. (Suggestions in Appendix D, Core Curriculum books.)

Prepare Any Activities



Choose which (if any) of the Bible Truth games and crafts activities you want to use in the session. Bear in mind your time frame as well as the developmental abilities and attention span of your children as you decide which/how many to prepare. **Look over the Discussion Sheet** and choose a few questions you might use to spark discussion with the children as they do their activities (especially good for ages 3's+). Pray for God to give you opportunities to talk about these things with the children.

Let Them Take It with Them



Make copies of the craft/take home sheets, if you are not already using them as one of your activities. You may also want to make copies of the story (see take-home version of each story included in Appendix C with the other take home resources) to have for parents to use with their children at home. There's a link on each craft/take home sheet to the story, if you don't make hard copies.

Store It



After your session is over, collect the resources and store them for future use. This curriculum can be used over and over for years to come.

Unit 11: The God Who Saves

UNIT OVERVIEW

We all have disobeyed God. We have all lost the wonderful special closeness with God that He meant for us to have with Him. No matter how hard we try, we can't ever be good enough to win back special closeness with God. No, we can't save ourselves, but God can. That's why He sent Jesus: to save us as a free gift from Him. Anyone who turns away from their sins and trusts in Jesus as their Savior, will receive His forgiveness. They will become His people, who know Him in their hearts by His Holy Spirit. And one day, God will take them to live with Him forever. This is the free gift God offers to you and me. God is so kind to us!

In this unit we will learn three truths about this wonderful, free gift God offers us.

UNIT BIBLE VERSE: Romans 6:23, ESV

"For the wages of sin is death, but the free gift of God is eternal life in Christ Jesus our Lord."

BIG QUESTION UNDER INVESTIGATION: How Can We Be Saved?

ANSWER: It Is God's Free Gift!

OPTIONAL Big Question 11 INTRODUCTION LESSON (Use Hide 'n' Seek Kids Unit 11 Material)

Story: The Case of the Most Important Question *Acts 16*

Bible Verse: Romans 6:23

BIBLE TRUTH 1: When We Tell God Our Sins and Turn Away from Them (3 Lessons Available)

Story: The Case of the Changed Climber *Luke 19:1-9*

Bible Verse: 1 John 1:8-9

BIBLE TRUTH 2: When We Trust in Jesus as Our Own Savior (3 Lessons Available)

Story: The Case of the Amazed, Mad Man *Acts 8-9*

Bible Verse: Romans 10:9-10

➔ BIBLE TRUTH 3: When the Holy Spirit Works in Our Hearts (3 Lessons Available)

Story: The Case of the Surprising, Second Birthday *John 3*

Bible Verse: Titus 3:5-7

Deep Down Detectives ESV Songs 11 Track Numbers

This is a listing of all songs mentioned in the unit curriculum. You may or may not choose to use all of the songs. They are listed in easy-reference order--NOT in the order used in the curriculum.

You may choose to simply burn a CD/load them onto an mp3 device in this order. Or, you may want to do what we do: choose the songs we want to use and create a play list of them in that order. Then, we burn a CD/upload the play list onto an mp3 device. A teacher only has to click forward to the next song, instead of hunting for the right track. The track number have been included as part of the title of each song, teachers will still have a reference to the track number listed in the curriculum (same as those listed below), even if you change the order on your customized play list.

SONGS USED EVERY UNIT OF THE CURRICULUM

- 1 The Classroom Song v.1
- 2 The Classroom Song v.2
- 3 The Classroom Song v.3
- 4 The Classroom Song v.4
- 5 Deep Down Detectives Theme Song
- 6 The Classroom Rules Song
- 7 Let's Pray Song
- 8 The Big Question Box Song
- 9 The Bible Chant Song
- 10 ACTS Prayer Song (Short Version)
- 11 ACTS Prayer Song (Full Version)

Why the Extra Songs?

Deep Down Detectives is a curriculum used by a wide age-span of kids. Sometimes one of the other songs is a better fit for your kids. Or, you may simply want to teach them more songs on the same Bible Truth. Use as many or as few as you want.

listen to or download songs for free at <https://praisefactory.org:Deep Down Detectives Music page>

Unit 11: The God Who Saves

- 12 Big Q & A 11 Song
- 13 Big Question 11 Song: How Can We Be Saved?
- 14 Big Question 11 Bible Verse Song: The Law of the Lord Psalm 19:7, ESV
- 15 *Extra Big Question 11 Bible Verse Song: The Law of the Lord Is Perfect Psalm 19:7, ESV (full version)*
- 16 *Extra Big Question 11 Bible Verse Song: The Law of the Lord Psalm 19:7, ESV (short version)*
- 17 Big Question 11 Hymn: Holy Bible, Book Divine
- 18 Big Question 11 Praise Song: The Best Book to Read Is the Bible

How Can We Be Saved?

God's Laws Are Perfect...

Bible Truth 1: When We Tell God Our Sins and Turn Away from Them

- 19 Bible Verse: Hear, O Israel Deuteronomy 5:1,7-21 , ESV (full version)
- 20 Bible Verse: Hear, O Israel Deuteronomy 5:1,7-21 , ESV (short version)

Bible Truth 2: When We Trust in Jesus as Our Own Savior

- 21 Bible Verse: By Works of the Law Romans 3:20-23, HCSB
- 22 *Extra Bible Verse: Now We Know Romans 3:19-24, ESV*
- 23 *Extra Bible Verse: For Christ Suffered Once for Sins 1 Peter 3:18, ESV*
- 24 *Extra Bible Verse: The Lord Looks Down Psalm 14:2-3, HCSB*
- 25 *Extra Bible Verse: All We Like Sheep Isaiah 53:6, ESV*
- 26 *Extra Bible Verse: Seek the Lord Isaiah 55:6-7, ESV*

Bible Truth 3: When the Holy Spirit Works in Our Hearts

- 27 Bible Verse: Love the Lord Matthew 22:37-40, ESV

Big Question 11, Bible Truth 3 Overview: Key Concepts

p.1

Unit 11: The God Who Saves

Unit Big Question (and Answer): How Can We Be Saved? It Is God's Free Gift!

Unit Bible Verse: "For the wages of sin is death, but the free gift of God is eternal life in Christ Jesus our Lord."
--- Romans 6:23, ESV

Bible Truth 3 Concept: It Is God's Free Gift... When the Holy Spirit Works in Our Hearts!

All of us are sinners. We would rather do things our own way rather than obey God. We have hearts that are dead and empty of love for Him and His good ways. We would never choose to love God on our own.

But guess what God does for His people? He treats them so much better than they deserve! He sends His Holy Spirit to work in their hearts. When they hear God's Word, He helps them know they are sinners. He helps them want to stop disobeying God and trust in Jesus as their Savior. He makes their hearts alive to God. Now, they know God and want to obey and love Him.

We can be God's people, too! We can ask God to send the Holy Spirit to work in our hearts. He can help us to ask God to forgive our sins, trust Jesus as our Savior, and live for Him. Then we can know God in our hearts, now; and when we die, we will go to live perfectly happily with Him forever.

Bible Truth 3 Bible Verse: Titus 3:5, ESV

"...He saved us, not because of works done by us in righteousness, but according to his own mercy, by the washing of regeneration and renewal of the Holy Spirit."

Learn a Little: "He saved us by the Holy Spirit."

Meaning

We can never please God with our own, good works. Only through Jesus' perfect life offered up in the place of sinners can we be saved. And what a salvation it is! God, Himself, sends His Holy Spirit to work in the hearts of His people. He gives them the gift of faith. He helps them turn away from their sins. He makes them clean of their sins and all new on the inside. This is how we, too, can become God's people--His heirs; that is, His children who will receive eternal life and live with Him forever.

Bible Truth 3 ACTS Prayer

- A** God, we praise You for being the Changer of the hearts of sinful people, like us.
- C** God, we confess that we are all sinners. We have hard hearts that are slow to believe, love, and obey You. We need Jesus to save us!
- T** Thank You for sending Your Holy Spirit to work in the hearts of people like us, so we can know You, love You, and live for You. You give us what we need but could never get on our own.
- S** God, send the Holy Spirit to work in our hearts. Give us faith as we hear Your Word, the Bible. Help us to turn away from our sins and trust in Jesus as our Savior. Make us new creations! Give us the new birth! We want to know You and live for You! In Jesus' name we pray, Amen.

Bible Truth 3 Story**The Case of the Surprising, Second Birthday**

John 3

Big Question 11, Bible Truth 3 Overview: Key Concepts

p.2

Songs Used in Bible Truth 3

Big Q & A 11 Song

Big Question 11 Song: How Can I Be Saved?

Big Question 11 Bible Verse Song: The Free Gift of God Is Eternal Life Romans 6:23, ESV

Big Question 11 Hymn: Grace Greater than All Our Sin, refrain

Big Question 11 Praise Song: Blessed Be the Name



Bible Truth 3 Bible Verse Song: He Saved Us Titus 3:5-7, ESV

Extra Bible Truth 3 Bible Verse Song: I Will Give You a New Heart Ezekiel 36:26, ESV

listen to or download songs for free at <https://praisefactory.org>: Deep Down Detectives Music page

1. GETTING STARTED

 = follow the stars for a short & simple lesson plan

<p>Intake Activity Ideas</p>	<p>Choose one of these open-ended activities to include children as they join the class:</p>	
<p>Free Play Time <i>suggestions in Appendix D</i></p>	<p> Offer your own or some of the easy-to-make, free play activities suggested in Appendix D.</p>	
<p>OR Sing-along Music Time <i>lyrics and sheet music, Appendix A</i> <i>listen to or download songs for free at https://praisefactory.org/Deep Down Detectives Music page</i></p>	<p>Music from Deep Down Detectives (DDD) ESV Songs 11: Big Q & A 11 Song Big Question 11 Song Big Question 11 (Unit) Bible Verse Song: The Free Gift of God Is Eternal Life Romans 6:23, ESV Big Question 11 Hymn: Grace Greater than All Our Sin, refrain Big Question 11 Praise Song: Blessed Be the Name Bible Truth 3 Bible Verse Song: Love the Lord Matthew 22:37-40, ESV Bible Truth 3 Bible Verse Song: Love the Lord Matthew 22:37-40, ESV</p>	<p><i>DDD ESV Songs 11, track 12</i> <i>DDD ESV Songs 11, track 13</i> <i>DDD ESV Songs 11, track 14</i> <i>DDD ESV Songs 11, track 15</i> <i>DDD ESV Songs 11, track 16</i> <i>DDD ESV Songs 11, track 21</i> <i>DDD ESV Songs 11, track 22</i></p> <p><i>Add more fun to Sing-along Music Time by adding a Music, Movement & Memory Activity. These activities are listed on p.10 of this lesson plan with the Response Activities. Instructions found in Appendix B.</i></p>
<p>OR Bible Verse Memory Game <i>instructions found in Appendix B</i></p>	<p>Lesson 1 Game: Duck, Duck, Goose Lesson 2 Game: Slap, Clap and Stack Lesson 3 Game: Simon Says How</p> <p><i>These activities are also included on p.10 of this lesson plan with the Response Activities.</i></p>	
<p>2. OPENING CIRCLE TIME (<i>introduce the Bible Truth and tell the related Bible story</i>)</p>		
<p>Gathering the Children <i>lyrics and sheet music, Appendix A</i></p>	<p><i>Sing verse 1 of The Classroom Song to gather the children for Circle Time.</i></p> <p>The Classroom Song, verse 1 <i>DDD ESV Songs 11, track 1</i> Let's gather together to worship God, Let's gather together to worship God, Let's gather together to worship God, Come gather here with me!</p>	
<p>Welcome to Deep Down Detectives</p>	<p> "Welcome to Deep Down Detectives. We're so glad you've joined us! Detectives are people who look for answers to questions. In Deep Down Detectives, we look for answers to big questions about God. We dig deep down in the truths of God's Word to find them."</p>	

2. OPENING CIRCLE TIME, continued



= follow the stars for a short & simple lesson plan

<p>Deep Down Detectives Theme Song</p> <p><i>lyrics and sheet music, Appendix A</i></p>	<p>"Let's sing our Deep Down Detectives Theme Song."</p> <p>Deep Down Detectives Theme Song Deep Down Detectives Theme Song DDD ESV Songs 11, track 5</p> <p>We're Deep Down Detectives, diggin' deep in God's Word, For truths about God and His plans for this world, We're seeking to love Him, with all of our heart, We're Deep Down Detectives! Come on! Let's start!</p>
<p>Classroom Rules Song</p> <p><i>lyrics and sheet music, Appendix A</i></p>	<p>There are two very important things that Deep Down Detectives do together: we worship God and we love one another. Our Classroom Rules Song reminds us how we should act. Let's sing it."</p> <p>Classroom Rules Song DDD ESV Songs 11, track 6</p> <p>Shh, be quiet while someone is talking, Raise your hand, if you have something to say, Don't touch your friend, sitting beside you, Obey your teachers, Be kind as you play. These are our classroom rules, These are our classroom rules, They help us worship God and love one another, These are our classroom rules.</p>
<p>Opening Prayer Time</p> <p><i>lyrics and sheet music, Appendix A</i></p>	<p>"Children, we need God's help to keep these rules. Let's ask Him to help us right now. Let's get ready and pray."</p> <p>Let's Pray DDD ESV Songs 11, track 7</p> <p>1-2-3! Fold your hands, Bow your head, Close your eyes. Let's pray! (<i>repeat</i>)</p> <p>"Let's pray:"</p> <p>Opening Prayer </p> <p>Dear Lord, We're so glad to get to gather together to worship You! Please help us keep the classroom rules. Please help us to love You and learn about You today. In Jesus' name we pray. Amen.</p>

2. OPENING CIRCLE TIME, continued

★ = follow the stars for a short & simple lesson plan

Reveal the Big Question
Introduce the Big Question Box/Briefcase

lyrics and sheet music, Appendix A

“Detectives INVESTIGATE things. That means they ask questions and look for answers. Deep Down Detectives investigate big questions about God. The Big Question we are investigating today is right inside our Big Question Box/Briefcase.

The Big Question Box Song

DDD ESV Songs 11, track 8

We’ve got a big box,
All closed up and locked,
Filled with the truths of God’s Word.

We’ve got a brief case,
There’s no time to waste,
Come on, kids, let’s open it up!

The Big Question under Investigation

VISUAL take out AID



of BQB

Big Question & Answer Sign, front side

**found in the DDD Unit 11 Visual Aids, ESV Book*

Ok, who would like to open for me and pull out the Big Question?”

Choose a child to open the box/briefcase, take out the Big Question and hand it to you, then hold up the Big Question sign for all the children to see, and say:

★ The Big Question we are investigating today is Big Question Number 11:

How Can We Be Saved?

and the Answer is:

It Is God’s Free Gift!

Big Question Meaning

★ We all have disobeyed God. We have all lost the wonderful special closeness with God that He meant for us to have with Him. No matter how hard we try, we can’t ever be good enough to win back special closeness with God.

No, we can’t save ourselves, but God can. That’s why He sent Jesus: to save us as a free gift from Him. Anyone who says “sorry” to God for their sins and trusts in Jesus as their Savior, He will forgive all their sins. God will give them special closeness with Himself right now. Then one day, He will take them to live with Him forever. This is the free gift God offers to you and me. God is so kind to us!

Big Question Songs

★ “Let’s sing our Big Question Song:

Big Q & A 6 Song

lyrics and sheet music, Appendix A

Big Q & A 11 Song

DDD ESV Songs 11, track 12

(adapted version of “Here We Go Looby-Loo”)

How can we be saved?
How can we be saved?
How can we be saved?
It is God’s free gift!

2. OPENING CIRCLE TIME, continued



= follow the stars for a short & simple lesson plan

<p>Learning about the Big Question (use one or both)</p> <p>★</p>	<p>Repeat the Big Question and Answer again: "How Can We Be Saved? It Is God's Free Gift!"</p> <p>Say: "Hmmm, I wonder what that means... Let's do our action rhyme/sing our song that explains it."</p> <p>Then do the action rhyme or sing the song using any of the optional motions suggested, if desired.</p>	
<p>Big Question Action Rhyme</p>	<p>Big Question 11 Action Rhyme</p> <p>I disobey God, I need a Savior! You disobey God, You need a Savior! We all disobey God, We all need a Savior! Oh, what a sad, sad day!</p> <p>But... God has a wonderful, free gift for me! A wonderful, free gift for you! God has a wonderful, free gift for us all. God will forgive our sins through Jesus! Oh, what a happy, happy day!</p>	<p>(POSSIBLE ACTIONS)</p> <p><i>Point to self</i> <i>Point out to others</i></p> <p><i>extend arms out wide to each side</i> <i>make a sad face</i></p> <p><i>Point to self</i> <i>Point out to others</i></p> <p><i>extend arms out wide to each side</i> <i>cheer and jump up and down for this best of news</i></p>
<p>Big Question (Action Rhyme) Song</p> <p>★</p> <p><i>lyrics and sheet music, Appendix A</i></p>	<p>Big Question 11 Action Rhyme/ Song</p> <p>Refrain</p> <p>How can we be saved? How can we be saved? How can we be saved? It's God' free gift. How can we be saved? How can we be saved? How can we be saved? It's God's free gift through Christ.</p> <p>Verse 1</p> <p>I disobey God, I need a Savior, You disobey God, You need a Savior, We all disobey God, We need a Savior. To save us from our sins. <i>Refrain</i></p> <p>Verse 2</p> <p>Jesus, He paid the price, the perfect sacrifice, On the cross, gave His life, Bought us eternal life, Takes away all our sin, Makes our hearts clean within, When we repent and believe in Him. <i>Refrain</i></p>	<p style="text-align: right;"><i>DDD ESV Songs 11, track 13</i></p> <p>(POSSIBLE ACTIONS)</p> <p><i>point up to God in heaven</i></p> <p><i>Point to self</i> <i>Point out to others</i></p> <p><i>extend arms out wide to each side</i></p> <p><i>make a cross with your index fingers</i></p> <p><i>Touch heart</i> <i>Make prayer hands and bow head</i></p>

2. OPENING CIRCLE TIME, continued

★ = follow the stars for a short & simple lesson plan

Learning the Bible Truth

VISUAL take out

AID



of BQB

VISUAL AID

All the Bible Truths Sign

★ "It is God's free gift" is a good beginning, but there's so more to learn. So it's time for us to dig down even deeper for more answers to our Big Question about God. We're going to be learning **THREE** Bible truths that all tell us more about this wonderful, free gift God offers us.

Who would like to hand me the picture with our three Bible truths on it? It's in the Big Question Box/Briefcase." *Choose a child to get it and hand it to you, then hold it up and show them the pictures of the three truths they will be learning.*

Bible Truth Clue

VISUAL take out

AID



of BQB

Bible Truth Clue Sign,

front side

VISUAL AID

After everyone has had a good look, say...

"Ok, we've learned two truths about God's free gift of salvation. They are: "When We Tell God Our Sins and Turn Away from Them"; and, "When We Trust in Jesus as Our Own Savior." (point to picture as you identify each Bible Truth). Now let's look at our Bible Truth Clue sign and see if we can figure out which of these three truths we will be learning about today. Who would like to get it out of the Big Question Briefcase for me?"

**"How Can We Be Saved?
It Is God's Free Gift!
When the Holy Spirit Works in Our ????!"**

Hint

We're missing one word. Here's the hint to what the missing word is. It says: "What did God put deep inside of us so we can know and love Him? It starts with an "h" and it rhymes with "starts."

Can you guess? It's "HEARTS."

So the Bible Truth we are learning today is:

(uncover answer from bottom of sign, show it to them and say:)

★ **"How Can We Be Saved?
It Is God's Free Gift!
When the Holy Spirit Works in Our HEARTS!"**

Bible Truth Meaning

★ And here is what this Bible Truth means: *(read the meaning off of the back of the sign, say:)*

All of us are sinners. We would rather do things our own way rather than obey God. We have hearts that are dead and empty of love for God and His good ways! We would never choose to love Him on our own.

But guess what God does for His people? He treats them so much better than they deserve! He sends His Holy Spirit to work in their hearts. When they hear God's Word, He helps them know they are sinners. He helps them want to stop disobeying God and trust in Jesus as their Savior. He makes their hearts alive to God and gives them a special closeness with Him. Now they want to obey Him and love Him.

We can be God's people, too! We can ask God to send the Holy Spirit to work in our hearts. He can help us to ask God to forgive our sins, trust Jesus as our Savior, and live for Him. Then we can have special closeness with God now; and when we die, we will go to live perfectly happily with Him forever.

2. OPENING CIRCLE TIME, continued

★ = follow the stars for a short & simple lesson plan

Learning the Bible Verse

"And how do I know this is true? God tells me so in His special book, the Bible."

The Bible Chant Song

Say or sing the Bible Chant Song.

lyrics and sheet music, Appendix A

The Bible Chant Song

DDD ESV Songs 11, track 9

The Bible, the Bible,
Let's get out the Bible.
Let's hear what God has to say.
The Bible, the Bible,
God's given us the Bible.
It's His Word for us to learn and obey! Yay!

Bible Verse

DDD 11.3 Bible Verse-front side (in the DDD Bible folder)

"Who would like to get our Bible folder out of the Big Question Briefcase for me?"

VISUAL AID

Place verse in take out



of BQB

DDD Bible Folder

Choose a child to open the briefcase, take out the "Bible" folder and hand it to you. Remove the Bible Verse Picture from the "Bible" folder and hold it up for all the children to see, then say:

Titus 3:5 tells us:

★ **Titus 3:5, ESV**

*found in the DDD Unit 11 Visual Aids, ESV Book

"...He saved us, not because of works done by us in righteousness, but according to his own mercy, by the washing of regeneration and renewal of the Holy Spirit."

Learn a Little: "He saved us by the Holy Spirit."

Bible Verse Meaning

★ **What does that mean?**

We can never please God with our own, good works. Only through Jesus' perfect life offered up in the place of sinners can we be saved. And what a salvation it is! God, Himself, sends His Holy Spirit to work in the hearts of His people. He gives them the gift of faith. He helps them turn away from their sins. He makes them clean of their sins and all new on the inside. This is how we, too, can become God's people--His heirs; that is, His children who will receive eternal life and live with Him forever.

2. OPENING CIRCLE TIME, continued

 = follow the stars for a short & simple lesson plan

**Bible Verse
Song**

*lyrics and sheet music,
Appendix A*

You might also enjoy:

*I Will Give You a New Heart
Ezekiel 36:26, ESV
DDD ESV Songs 11, track 22*

We've said our Bible verse, now let's sing it!

Titus 3:5-7

DDD ESV Songs 11, track 21





He saved us, he saved us,
By regeneration
And renewal of the Spirit.
He saved us, he saved us,
By the Holy Spirit.

The Holy Spirit whom he poured out,
On us richly,
Through Jesus Christ our Lord,
The Holy Spirit whom he poured out,
On us, through Jesus Christ.

Titus Three, verses five through seven.

2. OPENING CIRCLE TIME, continued

★ = follow the stars for a short & simple lesson plan

<p>Getting into the Case</p>	<p>"Now it's time to do a bit more deep down investigating. Let's see what Detective Dan wants us to help him figure out. Would someone like to get it out for me?"</p>
<p>Listening Assignments</p> <p>Place in  take out  of BQB</p>	<p>NOTE: Listening assignments are most suitable for ages 3+. Skip straight to the Bible story (see bottom of this page), if working with 2 year olds.</p> <p>"Let's open up our listening assignment and see what we are supposed to figure out today.</p> <p>Choose a child to take out the Listening Assignment (from the DDD Bible Folder) and hand it to you. Read Detective Dan's letter to the children that includes the listening assignment. The listening assignments are summarized below:</p>
<p>VISUAL AID</p> <p></p> <p>DDD Unit 11 Visual Aids, ESV</p>	<p>Detective Dan's Lesson #1 Listening Assignment:</p> <p>I need to know:</p> <ol style="list-style-type: none"> 1. What special kind of second birthday Did Jesus promised to all who trust in him as her Savior? 2. To Who did Jesus tell about this birthday? What did they find so surprising about it?
<p>VISUAL AID</p> <p></p> <p>DDD Unit 11 Visual Aids, ESV</p>	<p>Detective Dan's Lesson #2 Listening Assignment:</p> <p>Our Bible Verse is Titus 3:5-7:</p> <p>"...He saved us, not because of works done by us in righteousness, but according to his own mercy, by the washing of regeneration and renewal of the Holy Spirit."</p> <p>I need to know:</p> <ol style="list-style-type: none"> 1. What kind of special, second birthday does God give to each of His people? 2. Who does God send to work in their hearts and give them this special, second birthday?
<p>VISUAL AID</p> <p></p> <p>*Listening Assignment #3 includes the Assignment Sheet, plus 6 clue pictures*</p> <p>DDD Unit 11 Visual Aids, ESV</p>	<p>Detective Dan's Lesson #3 Listening Assignment:</p> <p>I found six clues, but two of them are NOT in the story. They are: a farmer, a pizza, a leaf, an important city person, a heart, and the moon. Hold each of them up for the children to see as you identify them.</p> <p>I need to know:</p> <ol style="list-style-type: none"> 1. Which four belong in the story and which two don't? 2. Who did the Holy Spirit work inside of as they listened to Jesus preach? What special birthday did God give them when he worked?
<p>Tell the Bible Story ★</p> <p>Place story & pics in  take out  of BQB</p> <p>DDD Unit 11 Visual Aids, ESV</p> <p>Story text included in this book right after this lesson plan and in Visual Aids book</p>	<p>★ Then say, "Ok, Deep Down Detectives! Put on your best listening ears and see if you can hear the answers to Detective Dan's questions. When I finish telling the story, we will see if we can answer all the questions."</p> <p>★ Bible Story: The Case of the Surprising, Second Birthday</p> <p>John 3</p> <p>Read the Bible Truth story, putting up the storyboard pictures as you tell it. Then, have the children answer the listening assignment. Present the gospel and lead in prayer.</p> <p>*Answers to questions; the gospel; and, ACTS prayer are included with the story text.*</p>

Lesson Plan: Big Question 11, Bible Truth 3

use with all THREE lessons

2. OPENING CIRCLE TIME, continued

★ = follow the stars for a short & simple lesson plan

<p>Story Response Song(s)</p> <p>Hymn</p> <p><i>lyrics and sheet music, Appendix A</i></p>	<p><i>As attention span and time allow, you might want to end with one of the following songs which also tie in with the unit. If desired, use the Music and Movement activity ideas while singing, listed with the Response Activities.</i></p> <p>Grace that Is Greater than All Our Sin <i>DDD ESV Songs 11, track 15</i></p> <p>Verse 1 Grace, grace, God's grace, Grace that will pardon and cleanse within; Grace, grace, God's grace, Grace that is greater than all our sin.</p> <p>Tie-in: "Children do you know what the word "grace" means? It means a free gift that we don't deserve! And what grace--what free gift-- does God offer us through Jesus? To forgive us and save us from the punishment we deserve for disobeying God! Let's sing of God's marvelous grace!"</p>
--	---





<p>Praise Song</p> <p><i>lyrics and sheet music, Appendix A</i></p>	<p>Praise Song: Blessed Be the Name <i>DDD ESV Songs 11, track 16</i></p> <p>All praise to Him who reigns above, In majesty supreme. Who gave His Son for man to die, That He might man redeem!</p> <p>Tie-in: "How can we be saved? It is God's free gift through the Lord Jesus! There would be no hope for us, if God did not send Jesus to be our Savior. That's why God's people love to bless His name. They are so grateful that He paid for their sins so that they can know God and live with Him forever!"</p>
--	--

3. TAKING ACTION: Response Activities *(choose from among these activities)*

<p>Transition to Activities</p>	<p>★ Well, Deep Down Detectives, you've done a great job diggin' deep down for answers in the truths of God's Word. Now it's time to enjoy some activities."</p> <p><i>Tell children what activity/s you are providing for them: eTher free play or some of the response activities listed below. When you are ready to dismiss them, use this song to help the children transition in an orderly fashion to their next activity.</i></p> <p>"Children, let's sing our Time to Play Song. When we are finished you may get up and walk over to our next activity."</p>
--	--



<p>Classroom Song, verse 2</p> <p><i>lyrics and sheet music, Appendix A</i></p>	<p>Classroom Song, verse 2 <i>DDD ESV Songs 11, track 2</i></p> <p>We've gathered together to worship God, We've gathered together to worship God, And now it's time to play.</p> <p><i>Dismiss the children to whatever activities you have prepared for them to do.</i></p>
--	---

3. TAKING ACTION: Response Activities (choose from among these activities) ★ = short & simple lesson plan

<p>Response Activities</p>	<p>Choose one or more activities appropriate for your children, based on classroom time and developmental needs. Add the Discussion Sheet to any activity for deeper learning. ★</p>
<p>Bible Verse Memory Game</p> <p><i>game directions, Appendix B</i></p>	<p>Though listed with the opening activities, you may choose to use this Bible verse game here instead (or as a repeat).</p> <ul style="list-style-type: none"> • Lesson 1 Game: Duck, Duck, Goose • Lesson 2 Game: Slap, Clap and Stack • Lesson 3 Game: Simon Says How <p>Use the Discussion Sheet with this activity for even deeper learning ★</p>  <p>Discussion Questions</p>
<p>Music, Movement & Memory Activity</p> <p><i>game directions, Appendix B</i></p>	<p>A music activity that uses the songs from the Bible Truth and Big Question unit.</p> <ul style="list-style-type: none"> • DDD Songs for this Bible Truth, plus: • Lesson 1 Activity: Clap, Tap and Say • Lesson 2 Activity: Block Clappers • Lesson 3 Activity: Lullabies, Bells and Lions <p>Use the Discussion Sheet with this activity for even deeper learning ★</p>  <p>Discussion Questions</p>
<p>Bible Story Review Game</p> <p><i>game directions, Appendix B</i></p>	<p>A game that uses the storyboard pictures from the story to review the story.</p> <ul style="list-style-type: none"> • Lesson 1 Game: Fix Up the Mix Up • Lesson 2 Game: Take Me through the Tunnel • Lesson 3 Game: Missing in Action <p>Use the Discussion Sheet with this activity for even deeper learning ★</p>  <p>Discussion Questions</p>
<p>Coloring Pages/ Take Home Sheets</p> <p><i>in Appendix C</i></p> <p>★</p>	<p>A coloring page related to the lesson assignment question is provided for each lesson. On the back of each are the key concepts, a few questions and a song for parents to use with their children.</p> <p>NOTE: Upgrade your coloring sheet to a more interesting craft by offering simple embellishments, such as jiggly eyes, craft sand, glitter, glitter glue, colored paper dots (made with a hole punch), fabric scraps, etc. Make cut-to-size glued-on clothes, hair, etc for characters by using a copy of the coloring sheet, cutting out the selected portions and making them the patterns for whatever you want to cut out of fabric, paper, foil, etc.</p> <ul style="list-style-type: none"> • Lesson 1 Coloring Sheet Emphasis: Bible Truth • Lesson 2 Coloring Sheet Emphasis: Bible Verse • Lesson 3 Coloring Sheet Emphasis: ACTS Prayer <p>Use the Discussion Sheet with this activity for even deeper learning ★</p>  <p>Discussion Questions</p>
<p>Extra Crafts: Big Question Craft <i>in Appendix C</i></p> <p>Bible Verse Craft <i>in Appendix C</i></p> <p>Bible Story Puzzle <i>in Appendix C</i></p>	<p>These crafts are slightly more complex than the coloring/take home sheets:</p> <p>The Bible Concept Go-and-Tell Craft is a craft that summarizes the Bible concept and includes the Bible verse is included for those desiring more than a coloring sheet. This more complex craft will involve gluing, sticking, etc. Can be used at any time.</p> <p>The Bible Story Coloring Sheet provides a tie in between the Bible story and the Bible truth they are learning.</p> <p>The Storyboard Picture Placement Page has been made into a puzzle that can be cut out and re-assembled by the children. This provides a nice summary of the story.</p> <p>Use the Discussion Sheet with these activities for even deeper learning ★</p>  <p>Discussion Questions</p>
<p>Free Play Activities ★</p> <p><i>ideas in Appendix D</i></p>	<p>Offer your own or some of the easy-to-make, free play activities suggested in Appendix D.</p>

4. CLOSING CIRCLE TIME *(End-of-session activities for the last 5-10 minutes of class time)*

 = short & simple lesson plan

<p>Transition to Closing Circle</p> <p>Classroom Song, verse 3</p> <p><i>lyrics and sheet music, Appendix A</i></p>	<p><i>Use this song to help the children transition in an orderly fashion. Start singing this song and ask the children to gather with you for Closing Circle Time.</i></p> <p>Classroom Song, verse 3 <i>DDD ESV Songs 11, track 3</i></p> <p>It's time to get ready to go and tell, It's time to get ready to go and tell, Come gather here with me.</p>
<p>Closing Circle Time</p> <p>Classroom Song, verse 4</p> <p><i>lyrics and sheet music, Appendix A</i></p>	<p><i>When children are settled in the circle, say:</i></p> <p>"It's almost time for your parents to come pick you up. And do you know what that means? It means.... (draw this out to build anticipation and excitement)...that it's almost time to go home and...it's almost time to...Go and Tell! We have learned some big news about God today. God wants us to take and tell it to the whole world!"</p> <p>Classroom Song, verse 4 <i>DDD ESV Songs 11, track 4</i></p> <p>So what's our big news to go and tell, So what's our big news to go and tell, Can you tell me now?</p>
<p>Big News to Tell</p> <p>Big Question 11</p> <p><i>VISUAL AID</i></p> <p></p> <p><i>*found in DDD Unit 11 Visual Aids, ESV Book</i></p> <p><i>lyrics and sheet music, Appendix A</i></p> <p>Big Question 11, Bible Truth 3</p> <p><i>VISUAL AID</i></p> <p></p>	<p>"Let's see....there's so much big news to tell! There's so much we've learned!</p> <p>First of all, can you tell me the answer to our Big Question: "How Can We Be Saved?" <i>Hold up the Bible Truth Clue Picture.</i></p> <p>Say the answer with me: "It Is God's Free Gift!"</p> <p><i>(If desired, you can sing one/both of the Big Question songs.)</i> <i>DDD ESV Songs 11, tracks 12,13</i></p> <p>And what's one way He does this? What did we learn? <i>Point to the picture.</i></p> <p>When the Holy Spirit Works in Our Hearts!</p> <p>"And how do I know this is true? Can you tell me? Say it with me: "The Bible tells me so!" That's right!</p>
<p>Big Question 11 Bible Truth 3 Bible Verse</p> <p><i>VISUAL AID</i></p> <p></p> <p><i>*found in the DDD Unit 11 Visual Aids, ESV Book</i></p> <p><i>lyrics and sheet music, Appendix A</i></p>	<p>We learned: Titus 3:5-7, ESV</p> <p>"...He saved us, not because of works done by us in righteousness, but according to his own mercy, by the washing of regeneration and renewal of the Holy Spirit."</p> <p>Learn a Little: "He saved us by the Holy Spirit."</p> <p>What does that mean?</p> <p>We can never please God with our own, good works. Only through Jesus' perfect life offered up in the place of sinners can we be saved. And what a salvation it is! God, Himself, sends His Holy Spirit to work in the hearts of His people. He gives them the gift of faith. He helps them turn away from their sins. He makes them clean of their sins and all new on the inside. This is how we, too, can become God's people--His heirs; that is, His children who will receive eternal life and live with Him forever.</p> <p><i>(If desired, you can sing the Bible verse song.)</i> <i>DDD ESV Songs 11, track 21</i></p>

4. CLOSING CIRCLE TIME, continued



= follow the stars for a short & simple lesson plan

<p>Closing ACTS Prayer Time</p> <p>ACTS Prayer Chant</p> <p><i>lyrics and sheet music, Appendix A</i></p>	<p><i>Let's ask God to help us to remember this and even tell others this good news. Let's get ready and pray our ACTS prayer.</i></p> <p><i>And what does ACTS mean? Let's sing/say our ACTS Prayer Chant!</i></p> <p>ACTS Prayer Chant Song <i>DDDESV Songs 11, tracks 10,11</i></p> <p>A, Adoration, God, we praise You! C, Confession, Forgive us our sins. T, Thanksgiving, Thank You for Jesus, S, Supplication, Help us to live like Him.</p> <p style="text-align: right;">That's the ACTS prayer, my friend, Bow your head, Close your eyes, Shhh, Let's begin.</p>
<p>Closing ACTS Prayer</p>	<p>"Let's pray!"</p> <p><i>Lead the children in the ACTS prayer for this Bible Truth.</i></p> <p>A God, we praise You for being the Changer of the hearts of sinful people, like us.</p> <p>C God, we confess that we are all sinners. We have hard hearts that are slow to believe, love, and obey You. We need Jesus to save us!</p> <p>T Thank You for sending Your Holy Spirit to work in the hearts of people like us, so we can know You, love You, and live for You. You give us what we need but could never get on our own.</p> <p>S God, send the Holy Spirit to work in our hearts. Give us faith as we hear Your Word, the Bible. Help us to turn away from our sins and trust in Jesus as our Savior. Make us new creations! Give us the new birth! We want to know You and live for You!</p> <p>In Jesus' name we pray, Amen.</p>
<p>5. TAKING IT HOME <i>(Take Home Sheet)</i></p>	
<p>Clean up and Dismissal </p>	<p>"Now it's time to work together and clean up." <i>Have the children join you in cleaning up the room.</i></p>
<p>Coloring Pages/ Take Home Sheets </p> <p><i>in Appendix C</i></p>	<p><i>Give out the craft/take home sheet and any other papers from the session, as you dismiss children from class.</i></p> <p><i>(Reminder: The back side of the coloring page is the take home sheet for each lesson.)</i></p>
<p>Bible Story to Take-Home</p> <p><i>in Appendix C</i></p>	<p>You may also want to include a copy of the story along with the take home sheet. (However, each coloring sheet/take home sheet includes a note to parents telling where they can download the story from the Parent Resources section on the website.</p>

The Case of the Surprising, Second Birthday*John 3***Story-telling Tips**

Ahead of time:

1. Read the Bible verses and story. Pray!
2. Choose story action cues and prepare storyboard figures/Story Scenes, if using. (In Visual Aids book)
3. Practice telling story with the storyboard figures/Story Scenes, timing your presentation. Shorten, if necessary.

During your presentation:

1. Maintain as much eye contact as possible as you tell the story.
2. Put up storyboard figures/add story action cues/hold up Story Scenes as you tell the story. Allow the children to help you put them on the board, if desired.
3. Include the children in your story with a few questions about what they think will happen or words/concepts that might be new to them.
4. Watch the kids for signs that their attention span has been reached. Shorten, if necessary.

INTRODUCTION/ LISTENING ASSIGNMENTS

“Our story is called: The Case of the Surprising, Second Birthday. Here is your listening assignment.” Read from Detective Dan’s Listening Assignment signs, but questions are summarized below:

Detective Dan’s Lesson #1 Listening Assignment:

I need to know:

1. **What special kind of second birthday Did Jesus promised to all who trust in him as her Savior?**
2. **To Who did Jesus tell about this birthday? What did they find so surprising about it?**

Detective Dan’s Lesson #2 Listening Assignment:**Our Bible Verse is Titus 3:5-7:**

“...He saved us, not because of works done by us in righteousness, but according to his own mercy, by the washing of regeneration and renewal of the Holy Spirit.”

I need to know:

1. **What kind of special, second birthday does God give to each of His people?**
2. **Who does God send to work in their hearts and give them this special, second birthday?**

Detective Dan’s Lesson #3 Listening Assignment:I found six clues, but two of them are **NOT** in the story.

They are: a farmer, a pizza, a leaf, an important city person, a heart, and the moon.

Hold each of them up for the children to see as you identify them.

I need to know:

1. **Which four belong in the story and which two don’t?**
2. **Who did the Holy Spirit work inside of as they listened to Jesus preach? What special birthday did God give them when he worked?**

Read the assignment questions, THEN SAY,

“Ok, Deep Down Detectives! Put on your best listening ears and see if you can hear the answers to Detective Dan’s questions. When I finish telling the story, we will see if we can answer all the questions.”

Read the Bible Truth story, answer questions, present the gospel and lead in prayer.

Answers to questions; the gospel; and, ACTS prayer are included with the story text.

The Case of the Surprising, Second Birthday*John 3**Story with lines separating paragraphs (text in bold, optional interaction cues in italics)*

To the country, to the cities, went Jesus and His disciples. And everywhere they went, people came. Jesus taught them about God and did amazing things by God's power.

What kind of country people came to Jesus? Well, there were plain, country people like shepherds, fishermen, and farmers. And there were important country people, like the teachers of God's Word and government workers. Poor people, rich people. Good people, bad people. Sick people, healthy people. Fathers, mothers, and children. They all came to Jesus to hear Him teach about God and do amazing things.

And amazed they certainly were, by what they heard and saw. "This Jesus is not like any other teacher. What amazing things He says about God. What amazing things He does. He even heals sick people with just His words. Let's hear more. Let's see more," they exclaimed.

Soon, big crowds of country people followed Jesus, listening to Him teach about God and watching the amazing things He did by God's power.

But you know, Jesus wasn't the only one doing amazing things by God's great power. God, the Holy Spirit, was doing some amazing things, too.

For as some of those country people listened to Jesus talk and watched the amazing things He did, God, the Holy Spirit, was at work in their hearts, changing them.

What kind of changes do you think the Holy Spirit was doing in them?

The Holy Spirit helped them turn away from their sins and trust in Jesus as their Savior. Yes, by His Holy Spirit, God was giving these people the best gift of all: the gift of being saved by faith in Jesus.

This wonderful gift meant God forgave their sins and made them His people. They could know and love God in their hearts. And one day, when they died, they would go live with Him, face-to-face forever. What a wonderful thing the Holy Spirit was doing as those country people listened to Jesus!

But God didn't just care about country people. He cared about city people, too. So, Jesus and His disciples left the country and went to the great city of Jerusalem. And what did Jesus do when He went there?

Can you guess?

Jesus taught them about God and did amazing things by God's great power, just like He had in the country.

All sorts of city people came to Jesus. Plain, city people, like the people who sold things in the markets, came. Important city people, like the Pharisees (the teachers of God's Word) and government workers, came, too. Poor people, rich people. Good people, bad people. Sick people, healthy people. Fathers, mothers, and children. They all came to Jesus to hear Him teach about God and do amazing things.

Story with lines separating paragraphs (text in bold, optional interaction cues in italics)

And amazed they certainly were, by what they heard and saw. "This Jesus is not like any other teacher. What amazing things He says about God. What amazing things He does. He even heals sick people with just His words. Let's go hear more. Let's go see more," they exclaimed.

Soon, big crowds of city people followed Jesus, listening to Him teach about God and watching the amazing things He did by God's power.

But you know, Jesus wasn't the only one doing amazing things by God's great power in the big city of Jerusalem. Can you guess who else was at work?

Can you guess who?

It was God, the Holy Spirit. He had done amazing things in the country people; and now, He was doing amazing things in the city people, too. For as some of those city people listened to Jesus talk and watched the amazing things He did, God, the Holy Spirit, worked in their hearts, changing them. He helped them turn away from their sins and trust in Jesus as their Savior.

Yes, by His Holy Spirit, God was giving these people the best gift of all: the gift of being saved by faith in Jesus.

This wonderful gift meant God forgave their sins and made them His people. They could know and love God in their hearts. And one day, when they died, they would go live with Him, face-to-face forever. What a wonderful thing the Holy Spirit was doing as those city people listened to Jesus!

Now, among the city people who came to Jesus, was a man named Nicodemus. Nicodemus was NOT a plain, city person. He was one of the most important people in both city AND country!

Can you guess what Nicodemus did that would have made him so important?

Nicodemus was one of the head teachers of God's Word. He had spent years and years learning God's Word, then years and years teaching it to others. People looked to Nicodemus to teach them how to live to please God and obey His laws.

But when Jesus came to Jerusalem, Nicodemus just shut his mouth and listened and watched. He could see that Jesus was a teacher unlike any other. A teacher especially sent by God. When Nicodemus was around Jesus, he didn't feel like a teacher anymore. He felt like a learner. "No one could do the things Jesus does if God had not sent Him," Nicodemus thought.

What amazed Nicodemus the most was what was happening in the city people who came to Jesus. Nicodemus had taught the people to work hard to obey God's good laws. These good works were how to please God, he taught them. People listened to Nicodemus when he taught, but they rarely ever changed.

But when Jesus taught, people were turning away from the bad things they had been doing! They were putting their trust in God! Jesus was teaching, and people were CHANGING!

Story with lines separating paragraphs (text in bold, optional interaction cues in italics)

What was going on? What was changing these people? Nicodemus wanted to know. He decided he would go to find Jesus and talk to Him, all by himself. So one night, Nicodemus made his way down the dark streets of Jerusalem to the place where Jesus stayed.

That night as they talked, Jesus answered Nicodemus' questions. Nicodemus was a good Pharisee. He taught the people that only by keeping all of God's good laws could they be God's people and be a part of God's kingdom. But Nicodemus had it wrong. Now, Jesus would teach the teacher.

"No one can become one of God's people and part of His kingdom unless they are born again," Jesus told him.

Nicodemus listened to Jesus' words. This time, he wasn't just amazed. He was confused!

Can you guess what confused him?

"Born again? How can this be, Jesus? I'm a full-grown man. Do I have to be born like a baby from a mother again? I don't understand," Nicodemus told Jesus.

"This is a new birth in your heart, not your body. Only God's Holy Spirit working in your heart can make you one of God's people," Jesus explained. "The Holy Spirit cleans a heart of sin, just like water cleans away dirt. He helps people repent. That is, He helps them not want to disobey God anymore. He helps them love God and trust in Me as their Savior," Jesus told Nicodemus. "And when the Holy Spirit works, He makes such a big change in your heart you become a new person on the inside, like being born again," Jesus said.

"How can this be?" Nicodemus asked, still trying to understand.

"Nicodemus, you are one of the best teachers of God's Word, yet you don't understand?" Jesus replied. "This why God has sent Me, His Son, from heaven. Yes, God loved the world so much that He sent Me to be the Savior. Whoever believes in Me won't be punished by God for their sins. They will have eternal life," Jesus said. "I will be lifted up on the cross and will pay for their sins, Myself. They will be God's people. They will live with God in His Kingdom forever," Jesus explained.

Nicodemus had much to think about that night as he went home. Jesus had taught him so much about God. New things he had never understood before. Jesus is God's Son, the Savior. The Holy Spirit works inside people to help them believe and make them brand-new people. God's people. What big ideas!

Did the Holy Spirit work in Nicodemus' heart as he thought about these things? It seems that He did. Who was it who helped take down Jesus' body from the cross when He died for the sins of God's people? It was Nicodemus! And who was it who took Jesus' body and buried it in a tomb? It was Nicodemus! Some say, Jesus' enemies made Nicodemus stop being a head teacher of God's Word because he believed in Jesus. The Bible doesn't tell us that part of Nicodemus' story.

But something I DO know for sure, is that we can ask God's Holy Spirit to work in our hearts right NOW! He can help us to turn away from disobeying God and to trust in Jesus as our own Savior. Yes, God offers to give even you and me the wonderful, free gift of salvation through Jesus. This is how we can become God's people and enjoy Him forever. Ask God to work in your heart. He loves to answer this prayer!

Cracking the Case: (story wrap-up for Listening Assignments)

It's time to see how we did with our Listening Assignment.

Detective Dan's Lesson 1 Listening Assignment:

1. What special kind of second birthday did Jesus promise to all who trust in him as their Savior? To be a changed person, forgiven of their sins, and one of God's people forever.

2. To whom did Jesus tell about this birthday? What did he find so surprising about it? To Nicodemus. He didn't understand that the Holy Spirit is the One who works inside us and changes our hearts. He is the One who helps us repent and believe, so we can become God's people.

For You and Me:

That special, second birthday wasn't just for important people like Nicodemus. It's for anyone who turns away from their sins and trusts in Jesus as their Savior. Ask the Holy Spirit to work in your heart and help you. He loves to answer these prayers!

**Detective Dan's Lesson 2 Listening Assignment:
Our Bible Verse is Titus 3:5, ESV:**

"...He saved us, not because of works done by us in righteousness, but according to his own mercy, by the washing of regeneration and renewal of the Holy Spirit."

I need to find out:

1. What kind of special, second birthday does God give to each of His people? To be made a new person inside their heart. God forgives their sins and helps them trust in Jesus as their Savior.

2. Who does God send to work in their hearts and give them this special, second birthday? The Holy Spirit.

For You and Me:

That special, second birthday that God gave to His people long ago is something He still gives to people today. How? When they turn away from their sins and trust in Jesus as their Savior. Ask the Holy Spirit to come and work in your heart and help you do this. He loves to answer this prayer!

Detective Dan's Lesson 3 Listening Assignment:

Our six clues were: a farmer, a pizza, a leaf, an important city person, a heart, and the moon.

1. Which four belong in our story?

The farmer, the important city person, the heart and the moon belong.

2. Who did the Holy Spirit work inside of as they listened to Jesus preach? What special birthday did God give them when he worked? He worked inside of many country and city people. The Holy Spirit helped them turn away from their sins and trust in Jesus as their Savior. He changed their hearts so they would become God's people. This is the special, second birth of salvation through Jesus.

For You and Me:

The Holy Spirit work in the hearts of many as they listen to Jesus preach from God's Word long ago. And He still works in hearts today as we listen to God's Word. Ask Him to work in your heart. Ask Him to help you to turn away from your sins and trust in Jesus as your Savior.

The Gospel (story wrap-up if NOT using Listening Assignments)**Our Bible Truth is:****How Can We Be Saved?****It Is God's Free Gift....****When the Holy Spirit Works in Our Hearts!**

How can we be saved? It is God's free gift... when the Holy Spirit works in our hearts. All of us are sinners. We would rather do things our own ways rather than obey God. We have hearts that are dead and empty of love for Him and His good ways! We would never choose to love God on our own. We deserve God's punishment, but He is full of mercy! He sent His Son, Jesus, to be our Savior. Jesus lived a perfect life. Then on the cross, He suffered and died, giving His perfect life as the full payment for the sins of God's people. On the third day, Jesus rose from the dead. He had really beaten sin and death for them! We can become God's people, too, when we turn away from our sins and trust in Jesus as our Savior. God's Holy Spirit can work in our hearts, helping us to do this. And if we do, the Holy Spirit will go on working in our hearts the rest of our lives, helping us know God, love Him, and live for Him. Then one day, we will go to live with God forever. Ask Him to help you! He loves to do this!

Close in prayer.

Closing ACTS Prayer

- A** God, we praise You for being the Changer of the hearts of sinful people, like us.
- C** God, we confess that we are all sinners. We have hard hearts that are slow to believe, love, and obey You. We need Jesus to save us!
- T** Thank You for sending Your Holy Spirit to work in the hearts of people like us, so we can know You, love You, and live for You. You give us what we need but could never get on our own.
- S** God, send the Holy Spirit to work in our hearts. Give us faith as we hear Your Word, the Bible. Help us to turn away from our sins and trust in Jesus as our Savior. Make us new creations! Give us the new birth! We want to know You and live for You!

In Jesus' name we pray, Amen.

Go to Lesson Plan, p.9 for the script to the rest of the lesson.

Deep Down Discussion Sheet

use with all THREE lessons

Use with all response activities for deeper learning



P.1

Questions to aid discussion of the key concepts and for use in games

Be familiar with these questions and answers. Look for opportunities to ask questions and discuss their answers, such as while the children work on their coloring pages, as part of their response games, or during play time. Remember: your goal isn't to ask all these questions or only talk to the children about these things. It is to be deliberate in having good conversations with them, however much or little you have.

<p>BIG QUESTION</p> <p>Meaning</p> <p>Discussion Questions</p>	<p>How Can We Be Saved? It Is God's Free Gift!</p> <p>We all have disobeyed God. We have all lost the wonderful special closeness with God that He meant for us to have with Him. No matter how hard we try, we can't ever be good enough to win back special closeness with God. No, we can't save ourselves, but God can. That's why He sent Jesus: to save us as a free gift from Him. Anyone who turns away from their sins and trusts in Jesus as their Savior, will receive His forgiveness. They will become His people, who know Him in their hearts by His Holy Spirit. And one day, God will take them to live with Him forever. This is the free gift God offers to you and me. God is so kind to us!</p> <p><i>choose a few</i></p> <ol style="list-style-type: none"> 1. How can we be saved? <i>It is God's free gift.</i> 2. Who has disobeyed God? <i>We all have.</i> 3. What happened to the special closeness with God that God created us to have? <i>We lost it because we are sinners.</i> 4. Can we ever be good enough to win back special closeness with God? <i>No, we cannot.</i> 5. Who did God send as a free gift to save us? <i>Jesus.</i> 6. What must we do to receive God's free gift of salvation? <i>Turn away from our sins and trust in Jesus as our Savior.</i> 7. What does God promise to all who do this? <i>Forgive their sins, and make Him their people. They will know them in their hearts now, by His Holy Spirit. Then, after their bodies die, He will bring them to live with Him, happy forever!</i>
<p>BIBLE TRUTH</p> <p>Meaning</p> <p>Discussion Questions</p> <p><i>choose a few</i></p>	<p>It Is God's Free Gift... When the Holy Spirit Works in Our Hearts!</p> <p>All of us are sinners. We would rather do things our own way rather than obey God. We have hearts that are dead and empty of love for Him and His good ways. We would never choose to love God on our own.</p> <p>But guess what God does for His people? He treats them so much better than they deserve! He sends His Holy Spirit to work in their hearts. When they hear God's Word, He helps them know they are sinners. He helps them want to stop disobeying God and trust in Jesus as their Savior. He makes their hearts alive to God. Now, they know God and want to obey and love Him.</p> <p>We can be God's people, too! We can ask God to send the Holy Spirit to work in our hearts. He can help us to ask God to forgive our sins, trust Jesus as our Savior, and live for Him. Then we can know God in our hearts, now; and when we die, we will go to live perfectly happily with Him forever.</p> <ol style="list-style-type: none"> 1. Who are sinners? <i>All of us.</i> 2. Would we rather do things our way or God's way? <i>Our way!</i> 3. What are sinners' hearts empty of? <i>Love for God and His good ways.</i> 4. Do sinners choose God on their own? <i>No, they don't.</i> 5. Who does God send to work in hearts of His people? <i>The Holy Spirit.</i> 6. What does the Holy Spirit do in the hearts of God's people? <i>Helps them to know they are sinners; helps them want to stop disobeying God; helps them trust Jesus as their Savior.</i> 7. What book does God use? <i>His Word, the Bible.</i> 8. Can we ask the Holy Spirit to work in our hearts? <i>Yes, we can. He can help us say no to disobeying God and trust in Jesus as our Savior.</i>

Deep Down Discussion Sheet

use with all THREE lessons

P.2

Questions to aid discussion of the key concepts and for use in games

<p>THE GOSPEL</p>	<p>What is God's good news for you and me? <i>The gospel! How can we be saved? It is God's free gift... when the Holy Spirit works in our hearts. All of us are sinners. We would rather do things our own ways rather than obey God. We have hearts that are dead and empty of love for Him and His good ways! We would never choose to love God on our own. We deserve God's punishment, but He is full of mercy! He sent His Son, Jesus, to be our Savior. Jesus lived a perfect life. Then on the cross, He suffered and died, giving His perfect life as the full payment for the sins of God's people. On the third day, Jesus rose from the dead. He had really beaten sin and death for them! We can become God's people, too, when we turn away from our sins and trust in Jesus as our Savior. God's Holy Spirit can work in our hearts, helping us to do this. And if we do, the Holy Spirit will go on working in our hearts the rest of our lives, helping us know God, love Him, and live for Him. Then one day, we will go to live with God forever. Ask Him to help you! He loves to do this!</i></p>
<p>BIBLE TRUTH BIBLE VERSE</p> <p>Meaning</p> <p>Discussion Questions</p>	<p>"...He saved us, not because of works done by us in righteousness, but according to his own mercy, by the washing of regeneration and renewal of the Holy Spirit." --Titus 3:5-7, ESV</p> <p>Learn a Little: "He saved us by the Holy Spirit."</p> <p>We can never please God with our own, good works. Only through Jesus' perfect life offered up in the place of sinners can we be saved. And what a salvation it is! God, Himself, sends His Holy Spirit to work in the hearts of His people. He gives them the gift of faith. He helps them turn away from their sins. He makes them clean of their sins and all new on the inside. This is how we, too, can become God's people--His heirs; that is, His children who will receive eternal life and live with Him forever.</p> <p><i>choose a few</i></p> <ol style="list-style-type: none"> 1. Can we ever please God with our own, good works? <i>No.</i> 2. Whose perfect life can pay for our sins and save us? <i>Jesus'!</i> 3. Who does God send to work in our hearts? <i>The Holy Spirit.</i> 4. What does the Holy Spirit do inside of the hearts of people? <i>He helps them turn away from their sins and trust in Jesus as their Savior. He makes their hearts clean, as if they had never sinned. He lives inside of them and makes them God's people forever.</i> 5. Can we ask the Holy Spirit to work in our heart? <i>Yes, we can! God loves to answer this prayer!</i>
<p>BIBLE STORY</p> <p>Discussion Questions</p>	<p>The Case of the Surprising, Second Birthday <i>choose a few</i></p> <ol style="list-style-type: none"> 1. What were the country people and the city people think about Jesus? <i>They were amazed at the things He told them about God and the great things He did by God's power.</i> 2. Who was working in the hearts of people as Jesus taught them about God? <i>The Holy Spirit.</i> 3. What was the Holy Spirit doing in people's hearts? <i>He was giving them faith to believe in Jesus and to want to turn away from disobeying God and trust in Jesus as their Savior.</i> 4. Who was Nicodemus? <i>He was an important teacher of God's Word who lived in the big city of Jerusalem.</i> 5. What was something new that Jesus taught Nicodemus? <i>That no one can do enough good things to please God. We are all sinners. We all need God's Holy Spirit to come into our hearts and clean them of sin and give us faith to believe in Jesus.</i> 6. What is something we can ask God the Holy Spirit to do in our hearts today? <i>To work in our hearts, helping us to turn away from disobeying God and trust in Jesus as our Savior. Then, our hearts will be clean of sin and we will be born again as God's dearly-loved people. Ask Him to help you. He loves to answer this prayer!</i>

DEEP DOWN DETECTIVES

Curriculum Resources



**Appendix A:
Unit 11 Songs**

Deep Down Detectives ESV Songs 11 Track Numbers

This is a listing of all songs mentioned in the unit curriculum. You may or may not choose to use all of the songs. They are listed in easy-reference order--NOT in the order used in the curriculum.

You may choose to simply burn a CD/load them onto an mp3 device in this order. Or, you may want to do what we do: choose the songs we want to use and create a play list of them in that order. Then, we burn a CD/upload the play list onto an mp3 device. A teacher only has to click forward to the next song, instead of hunting for the right track. The track number have been included as part of the title of each song, teachers will still have a reference to the track number listed in the curriculum (same as those listed below), even if you change the order on your customized play list.

SONGS USED EVERY UNIT OF THE CURRICULUM

- 1 The Classroom Song v.1
- 2 The Classroom Song v.2
- 3 The Classroom Song v.3
- 4 The Classroom Song v.4
- 5 Deep Down Detectives Theme Song
- 6 The Classroom Rules Song
- 7 Let's Pray Song
- 8 The Big Question Box Song
- 9 The Bible Chant Song
- 10 ACTS Prayer Song (Short Version)
- 11 ACTS Prayer Song (Full Version)

Why the Extra Songs?

Deep Down Detectives is a curriculum used by a wide age-span of kids. Sometimes one of the other songs is a better fit for your kids. Or, you may simply want to teach them more songs on the same Bible Truth. Use as many or as few as you want.

Unit 11: The God Who Saves

- 12 Big Q & A 11 Song
- 13 Big Question 11 Song: How Can We Be Saved?
- 14 Big Question 11 Bible Verse Song: The Law of the Lord Psalm 19:7, ESV
- 15 *Extra Big Question 11 Bible Verse Song: The Law of the Lord Is Perfect Psalm 19:7, ESV (full version)*
- 16 *Extra Big Question 11 Bible Verse Song: The Law of the Lord Psalm 19:7, ESV (short version)*
- 17 Big Question 11 Hymn: Holy Bible, Book Divine
- 18 Big Question 11 Praise Song: The Best Book to Read Is the Bible

How Can We Be Saved?

God's Laws Are Perfect...

Bible Truth 1: When We Tell God Our Sins and Turn Away from Them

- 19 Bible Verse: Hear, O Israel Deuteronomy 5:1,7-21 , ESV (full version)
- 20 Bible Verse: Hear, O Israel Deuteronomy 5:1,7-21 , ESV (short version)

Bible Truth 2: When We Trust in Jesus as Our Own Savior

- 21 Bible Verse: By Works of the Law Romans 3:20-23, HCSB
- 22 *Extra Bible Verse: Now We Know Romans 3:19-24, ESV*
- 23 *Extra Bible Verse: For Christ Suffered Once for Sins 1 Peter 3:18, ESV*
- 24 *Extra Bible Verse: The Lord Looks Down Psalm 14:2-3, HCSB*
- 25 *Extra Bible Verse: All We Like Sheep Isaiah 53:6, ESV*
- 26 *Extra Bible Verse: Seek the Lord Isaiah 55:6-7, ESV*

Bible Truth 3: When the Holy Spirit Works in Our Hearts

- 27 Bible Verse: Love the Lord Matthew 22:37-40, ESV

Index of Songs

GENERAL CLASSROOM SONGS (USED EVERY LESSON, EVERY UNIT)	125
Lyrics:	
The Classroom Song vs.1-4	127
Deep Down Detectives Theme Song	128
The Classroom Rules Song	128
Let's Pray Song	129
The Big Question Box Song	129
The Bible Chant Song	130
ACTS Prayer Song	130
 Sheet Music :	
The Classroom Song vs.1-4	131
Deep Down Detectives Theme Song	131
The Classroom Rules Song	132
Let's Pray Song	132
The Big Question Box Song	133
The Bible Chant Song	133
ACTS Prayer Song	134
 Unit 11: The God Who Saves	
	135
 Unit 11 Songs Lyrics:	
Big Q & A 11 Song	137
Big Question 11 Song: How Can We Be Saved?	138
Big Question 11 Bible Verse Song: The Free Gift of God Is Eternal Life Romans 6:23, ESV	139
Big Question 11 Hymn: Grace Greater than All Our Sin, refrain	140
Big Question 11 Praise Song: Blessed Be the Name	141
 Unit 11 Songs Sheet Music	
Big Q & A 11 Song	142
Big Question 11 Song: How Can We Be Saved?	143
Big Question 11 Bible Verse Song: The Free Gift of God Is Eternal Life Romans 6:23, ESV	142
Big Question 11 Hymn: Grace Greater than All Our Sin, refrain	145
Big Question 11 Praise Song: Blessed Be the Name	145

Index of Songs, continued

How Can We Be Saved? It Is God's Free Gift..

Bible Truth 1: When We Tell God Our Sins and Turn Away from Them

Lyrics:

Bible Verse: If We Say We Have No Sin 1 John 1:8-9, ESV 149

Extra Bible Verse: If We Say 1 John 1:8-9, ESV 150

Sheet Music:

Bible Verse: If We Say We Have No Sin 1 John 1:8-9, ESV 151

Extra Bible Verse: If We Say 1 John 1:8-9, ESV 152

Bible Truth 2: When We Trust in Jesus as Our Own Savior

Lyrics:

Bible Verse: If You Confess with Your Mouth Romans 10:9-10, ESV 153

Extra Bible Verse: In My Father's House John 14:2-6, ESV 154

Sheet Music:

Bible Verse: If You Confess with Your Mouth Romans 10:9-10, ESV 155

Extra Bible Verse: In My Father's House John 14:2-6, ESV 156

Bible Truth 3: When the Holy Spirit Works in Our Hearts

Lyrics:

Bible Verse: He Saved Us Titus 3:5-7, ESV 157

Extra Bible Verse: I Will Give You a New Heart Ezekiel 36:26, ESV 158

Sheet Music:

Bible Verse: He Saved Us Titus 3:5-7, ESV 159

Extra Bible Verse: I Will Give You a New Heart Ezekiel 36:26, ESV 160

DEEP DOWN DETECTIVES

Curriculum Resources



General Classroom Songs

**(used every lesson
of the curriculum)**

Unit 11 Lyrics

The Classroom Song

DDD ESV 11 Songs, Tracks 1-4

Verse 1

Let's gather together to worship God,
Let's gather together to worship God,
Come gather now with me!

Verse 2

We've gathered together to worship God,
We've gathered together to worship God,
And now it's time to play.

Verse 3

It's time to get ready to go and tell,
It's time to get ready to go and tell,
Come gather here with me.

Verse 4

So what's our big news to go and tell,
So what's our big news to go and tell,
Can you tell me now?

Unit 11 Lyrics

Deep Down Detectives Theme Song

DDD ESV Songs 11, Track 5

We're Deep Down Detectives,
diggin' deep in God's Word,
For truths about God and His plans for this world,
We're seeking to love Him, with all of our heart,
We're Deep Down Detectives!
Come on! Let's start!

Words and Music: Constance Dever ©2015

Classroom Rules Song

DDD ESV Songs 11, Track 6

Shh, be quiet while someone is talking,
Raise your hand, if you have something to say,
Don't touch your friend, sitting beside you,
Obey your teachers, Be kind as you play.
These are our classroom rules,
These are our classroom rules,
They help us worship God and love one another,
These are our classroom rules.

Words and Music: Constance Dever ©2015

Unit 11 Lyrics

Let's Pray

DDD ESV Songs 11, Track 7

1-2-3!

Fold your hands,

Bow your head,

Close your eyes.

Let's pray! (*repeat*)

Words and Music: Constance Dever ©2015

Big Question Box Song

DDD ESV Songs 11, Track 8

The Big Question Box Song

We've got a big box,

All closed up and locked,

Filled with the truths of God's Word.

We've got a brief case,

There's no time to waste,

Come on, kids, let's open it up!

Words and Music: Constance Dever ©2015

Unit 11 Lyrics

The Bible Chant Song

DDD ESV Songs 11, Track 9

The Bible, the Bible,
Let's get out the Bible.
Let's hear what God has to say.
The Bible, the Bible,
God's given us the Bible.
It's His Word for us to learn and obey! Yay!

Words and Music: Constance Dever ©2015

The ACTS Prayer Song

DDD ESV Songs 11, Tracks 10,11

A: Adoration, God, we praise You,
C: Confession, Forgive us our sins,
T: Thanksgiving, Thank You for Jesus,
S: Supplication, Help us live like Him. (repeat)

That's the A-C-T-S prayer, my friend,
Bow your head, Close your eyes, Shhh,
Let's begin!

Words and Music: Constance Dever ©2016

The Classroom Song

DDD ESV Songs 11, Tracks 1-4

1. Let's ga - ther to - geth - er to wor - ship God. Let's ga - ther to -
 2. We've ga - thered to - geth - er to wor - ship God. We've ga - thered to -
 3. It's time to get read - y to go and tell, It's time to get
 4. So what's our big news___ to go and tell? So what's our big

6
 geth - er to wor - ship God. Come ga - ther here with me.
 geth - er to wor - ship God. And now it's time to play!
 read - y to go and tell. Come ga - ther here with me!
 news___ to go and tell? Can you tell me now?

Words and Music: Constance Dever ©2013

Deep Down Detectives Theme Song

DDD ESV Songs 11, Track 5

We're Deep Down De - tec - tives! Dig - gin' deep in God's Word, For truths a bout God, and_ His

4
 plans for this world, We're seek - ing to love_ Him, with

6
 all of our heart, We're Deep Down De - tec - tives! Come on! Let's start!

Words and Music: Constance Dever ©2014

The Classroom Rules Song

DDD ESV Songs 11, Track 6

C F G C F G

Shh! Be qui - et while some one is talk ing, Raise your hand when you have some thing to say,

5 F C F C G13 C

Don't touch your friend, sit ting be-side you, O -bey your teach -ers be kind as_ you play.

9 F G F C G

These are_ our class-room rules, These are_ our class room rules,_____ They help us

13 C F G F G C

wor-ship God and love___ one_ an-oth er, These___ are_ our class-room rules. Yeah!

Words and Music: Constance Dever ©2013

Let's Pray

DDD ESV Songs 11, Track 7

A C#m D A E A

One, two, three, Fold your hands, Bow your head, close your eyes, Let's pray!

5 C#m D A E

One, two, three, Fold___ your hands, Bow your head, close your eyes, Let's pray!

Words and Music: Constance Dever ©2013

The Big Question Box Song

DDD ESV Songs 11, Track 8

Musical score for 'The Big Question Box Song' in 4/4 time, key of Bb. The score consists of three staves of music with lyrics underneath. Chord symbols are placed above the notes.

Staff 1: Eb Ab Eb Ab Eb
 We've got a big_ box, All closed up and locked, Filled with the truths of God's

Staff 2: Bb Eb
 Word. We've got a brief_____ case,___ There's

Staff 3: Ab Eb Bb Eb
 no time to waste! Come on,___ kids! Let's o - pen it up!

Words and Music: Constance Dever ©2016

The Bible Chant Song

DDD ESV Songs 11, Track 9

Musical score for 'The Bible Chant Song' in 4/4 time, key of D major. The score consists of two staves of music with lyrics underneath. Chord symbols are placed above the notes.

Staff 1: A D E A D E A
 The Bi-ble, the Bi ble, Let's get out the Bi-ble, Let's hear what God has to say.____ The

Staff 2: D E A D E A
 Bi ble, the Bi-ble, God's gi-ven us the Bi ble, It's His Word for us to learn and o bey!_ Yay!

Words and Music: Constance Dever ©2013

The ACTS Prayer Song

C G G⁷ C

A: A-do-ra tion, "God,we praise You," C: Con-fes-sion, "For-give us our sins,"

5 C G G⁷ C

T: Thanks-giv ing, "Thank You for Je-sus, S: Sup-pli-ca-tion, "Help us live like Him."

9 C G G⁷ C

A: A-do-ra tion, "God,we praise You," C: Con-fes-sion, "For-give us our sins,"

13 C G G⁷ C

T: Thanks-giv ing, "Thank You for Je-sus, S: Sup-pli-ca-tion, "Help us live like Him."

17 2. C G F

live like_ Him." That's the A, C, T, S prayer, my friend, Bow your

20 G G⁷ C

head, close your eyes, shhh! Let's be - gin!

DEEP DOWN DETECTIVES

Curriculum Resources



Unit 11 Songs

(used with all 3 Bible Truths)

Unit 11 Lyrics

Big Q & A 11 Song

DDD ESV Songs 11, Track 12

How can we be saved?

How can we be saved?

How can we be saved?

It is God's free gift!

Words: Constance Dever Music: Adapted Nursery Rhyme ©2012

Unit 11 Lyrics

Big Question 11 Song: How Can We Be Saved?

DDD ESV Songs 11, Track 13

Refrain

How can we be saved? How can we be saved?
How can we be saved? It's God's free gift.
How can we be saved? How can we be saved?
How can we be saved? It's God's free gift through Christ.

Verse 1

I disobey God, I need a Savior,
You disobey God, You need a Savior,
We all disobey God, We need a Savior.
To save us from our sins. *Refrain*

Verse 2

Jesus, He paid the price, the perfect sacrifice,
On the cross, gave His life,
Bought us eternal life,
Takes away all our sin,
Makes our hearts clean within,
When we repent and believe in Him. *Refrain*

Unit 11 Lyrics

Unit 11 Bible Verse Song: DDD ESV Songs 11, Track 14

The Free Gift of God Is Eternal Life

The free gift of God is,
The free gift of God is,
The free gift of God is....what?
The free gift of God is eternal life
Through Jesus, through Jesus
The free gift of God is eternal life through Jesus. (repeat)
Romans Six, twenty-three.

Words: adapted from Romans 6:23, ESV Music: Constance Dever ©2016

Tie-in: How can I be saved? It is the gift of God through Jesus. That what the Bible tells us! When we say sorry to God for our sins and trust in Jesus as our Savior, He forgives us and saves us and promises us that we will get to know Him and live with Him forever...and that's what eternal life is!

Unit 11 Lyrics

Big Question 11 Hymn: Grace Greater than All Our Sin

DDD ESV Songs 11, Track 15

Grace, grace, God's grace,
Grace that will pardon and cleanse within;
Grace, grace, God's grace,
Grace that is greater than all our sin.

Words: Julie H. Johnston Music: Daniel B. Towner

Tie-in: How can we be saved? It is God's free gift! Do you know what the word "grace" means? It means something good that we don't deserve! God's grace is the very best gift of all. It is something very, very good and we certainly don't deserve it. It is God forgiving us of our sins and making us His special people forever, when we say "sorry" to Him for our sins and trust in Jesus as our Savior. God's grace is so great when we do this! It is greater than all our sin. He promises to pardon us--that is forgive us of every single time we disobey Him. Yes, through Jesus they are all paid for. And, He promises to make our sinful hearts clean, by His Holy Spirit. But that is just the beginning of His grace at work in us, when we become His people! His Holy Spirit will keep on working, helping us to know and love God more and more.

Unit 11 Lyrics

Big Question 11 Praise Song: Blessed Be the Name

DDD ESV Songs 11, Track 16

All praise to Him who reigns above i majesty supreme.
Who gave His Son for man to die,
That He might man redeem!

Blessed be the name,
Blessed be the name,
Blessed be the name of the Lord;
Blessed be the name,
Blessed be the name,
Blessed be the name of the Lord.

Words and Music: Anonymous

Tie-in: How can we be saved? It is God's free gift through the Lord Jesus! There would be no hope for us, if God did not send Jesus to be our Savior. That's why God's people love to bless His name. They are so grateful that He paid for their sins so that they can know God and live with Him forever!

Big Q & A 11 Song

Musical notation for the song 'Big Q & A 11 Song'. It consists of two staves of music in 4/4 time. The first staff starts with a C chord and contains the lyrics: 'How can we be saved? How can we be saved?'. The second staff starts with a C chord and contains the lyrics: 'How can we be saved? It is God's free gift!'. Chords G and G7 are also indicated above the second staff.

Words: Constance Dever Music: Adapted Nursery Rhyme ©2012

Romans 6:23 The Free Gift of God Is Eternal Life

Big Question 11 Bible Verse

Musical notation for the song 'Romans 6:23 The Free Gift of God Is Eternal Life'. It consists of seven staves of music in 4/4 time. The lyrics are: 'The free gift of God is, the free gift of God is, the free gift of God is, the free gift of God is... What? The free gift of God is e - ter - nal life in Je - sus, in Je - sus, The free gift of God is e - ter - nal life in - Je - sus. The free gift of God is, the free gift of God is, the free gift of God is... What? The free gift of God is e - ter - nal life in Je - sus, in Je - sus, The free gift of God is e - ter - nal life in - Je - sus. Ro mans Six: clap, clap, clap twen - ty - three.' Chords C, C7, F, Bb, and F are indicated above the staves.

Words: adapted from Romans 6:23 ESV Music: Constance Dever ©2012

Big Question 11 Song

4
D F#m Bm A D F#m Bm

How can_ we be saved? How can_ we be saved? How can_ we be saved? It's God's free

8 G A D F#m Bm A D F#m Bm

gift! How can_ we be saved? How can_ we be saved? How can_ we be saved?

15 A D G A D A D A

It's God's free gift through Christ! I dis-o - bey God! I need a Sav - ior! You dis-o -

23 D A G A D A A

bey God! You need a Sav - ior! We all dis-o - bey God! We need a Sav - ior! To save us

31 D F#m Bm A D

from our sins. How can_ we be saved? How can_ we be saved? How can_

39 F#m Bm G A D F#m Bm A D

we be saved? It's God's free gift! How can_ we be saved? How can_ we be saved?

46 F#m Bm A D G A D A

How can_ we be saved? It's God's free gift through Christ, Je - sus, He paid the price,

53 D A D A Bm A D A G A

The per - fect sa - cri - fice, On the cross gave His life! Bought us e - ter nal life, Takes a - way

60 D A D A D A D

all our sin, Makes our hearts clean with - in, When we re - pent and be - lieve in Him, How can_

68 F#m Bm A D F#m Bm G A

we be saved? How can_ we be saved? How can_ we be saved? It's God's free gift!

75 D F#m Bm A D

How can_ we be saved? How can_ we be saved? How can_

80 F#m Bm A D

we be saved? It's God's free gift through Christ!

Words and Music: Constance Dever ©2012

Grace That Is Greater than All Our Sin

Big Question 11 Hymn

E A E B E E A E

Grace, grace, God's grace, Grace that will par-don and cleanse with - in;

9 A E B E A E B A B E

Grace, grace, God's grace, Grace that is great-er than all our sin.

Words: Julia H. Johnston Music: Daniel B Towner

Blessed Be the Name

Big Question 11 Praise Song

E A E B E A

All praise to Him who reigns a-bove in maj-es - ty su - preme. Who gave His Son for man to die, That

7 E B E A E

He might man re - deem! Bless-ed be the name, bless-ed be the name, Bless-ed be the name of the

12 B E A E B E

Lord; Bless-ed be the name, bless-ed be the name. Bless-ed be the name of the Lord.

Words and Music: Anonymous

DEEP DOWN DETECTIVES

Curriculum Resources



**Unit 11 Bible Truth
Bible Verse Songs**

Bible Verse Song: If We Say We Have No Sin

DDD ESV Songs 11, Track 17

If we say we have no sin,
If we say we have no sin,
If we say we have no sin,
We deceive ourselves,
And the truth is not in us.

But...If we confess our sins...

He is faithful and just to forgive us our sins,
Faithful and just to forgive us our sins,
Faithful and just to forgive us our sins,
And to cleanse us from,
All unrighteousness.

First John One, verses eight and nine.

about this Bible verse:

Words: adapted from 1 John 1:8,9, ESV Music: Constance Dever ©2015

This verse reminds us that we are all sinners. We deceive ourselves if we think we are not. But, the good news is, that if we admit we are sinners and confess our sins to God, He is faithful and just and will forgive us our sins and save us through Jesus.

Unit 11 Bible Truth 1 Bible Verse Song Lyrics

Extra Bible Verse Song:
If We Say

DDD ESV Songs 11, Track 18

If we say we have no sin,
We deceive ourselves, and the truth is not in us,
The truth is not in us.
If we say we have no sin,
We deceive ourselves, and the truth is not in us,
The truth is not in us.

If we confess our sins,
He is faithful and just to forgive us our sins,
If we confess our sins,
He is faithful and just to forgive us our sins,
And to cleanse us from all unrighteousness.

First John One, verses eight and nine.

about this Bible verse:

Words: adapted from 1 John 1:8,9, ESV Music: Constance Dever ©2015

This verse reminds us that we are all sinners. We deceive ourselves if we think we are not. But, the good news is, that if we admit we are sinners and confess our sins to God, He is faithful and just and will forgive us our sins and save us through Jesus.

If We Say

F C Dm F C Bb
 If we say we have no sin, we de ceive our-selves, and the truth is not in us, the
 6 C F F C Dm F
 truth is not in us. If we say we have no sin, we de ceive our-selves, and the
 12 C Bb C F Bb C
 truth is not in us, the truth is not in us. If we con-
 18 Dm C Dm Bb C Dm Bb C Bb C Dm C Dm
 fess our sins, He is faith-ful and just to for-give us our sins. If we con-fess our sins, He is
 23 Bb C Dm C Bb
 faith-ful and just to for-give us our sins, and to cleanse us fro all un-
 27 C 1. 2. F C Bb
 righ teous ness. First John One, ver-ses eight and nine.

Words: adapted from 1 John 1:8,9, ESV Music: Constance Dever ©2015

Bible Verse Song:

DDD ESV Songs 11, Track 19

If You Confess with Your Mouth

If you confess, with your mouth, "Jesus is Lord,"
And believe in your heart,
That God raised Him from the dead,
You will be saved, you will be saved.
For with the heart, one believes and is justified.

If you confess, with your mouth, "Jesus is Lord,"
And believe in your heart,
That God raised Him from the dead,
You will be saved, you will be saved.
For with the mouth, one confesses and is saved.
Romans Ten: nine through ten.

about this Bible verse:

Words: Romans 10:9-10, ESV Music: Constance Dever ©2012

To believe something in your heart is to think that something is true. To confess something to others is to tell them what you think is true. Christians are those who believe in their hearts that Jesus is the Son of God, who died on the cross to save God's people from their sins. They believe that He rose from the dead on the third day, showing that He had beaten sin and death for them. They love telling this good news to others that they might believe and be saved, too. We must believe in our own hearts that He is our Savior and be willing to confess to others that He is our Lord, if we are to be saved!

Extra Bible Verse Song: DDD ESV Songs 11, Track 20

In My Father's House

"In my Father's house are many rooms," Jesus said.

"I go prepare, prepare a place for you.

You know the way."

"Lord, we don't know where You are going,"

Thomas said to Him.

"Lord, we don't know where You are going,

How can we know the way?"

"I am the Way, I am the Truth, I am the Life,"

Jesus answered.

I am the Way, I am the Truth, I am the Life,"

Jesus answered.

No one can come to the Father, except through me."

John Fourteen, two through six.

about this Bible verse:

Words: John 14:2-6, ESV Music: Constance Dever ©2012

On the night before He died on the cross, Jesus comforted Thomas and the other disciples that He was making the way for them to be saved. He called heaven, His Father's house and promises them that He is about to make the way for them to be able to live there. There was still much they didn't understand yet, but later, after He rose from the dead it all began to make sense. On the cross, He paid for God's people's sins. He made the way for them to go to heaven. They could depend upon Him and His promises. He was the truth. He would beat sin and death for them so they could have eternal life. He would prepare a place for them and all of God's people in heaven to be with Him. And one day, He will come back to take them to be there with Him forever. How wonderful that will be!

If You Confess with Your Mouth

B \flat Dm Gm B \flat Dm
 If you con - fess, with your mouth, "Je - sus is Lord," and be - lieve in your heart that God
 4 E \flat F B \flat Dm⁷ Gm Dm
 raised Him from the dead, you will be saved, you will be saved, For with the__ heart one be -
 8 B \flat F B \flat B \flat Dm B \flat F
 lieves and is just - i - fied. If you con - fess with your mouth, "Je - sus is Lord," and be -
 12 B \flat Dm E \flat F B \flat Dm
 lieve in your heart that God raised Him from the dead, you will be saved, you will be saved, For
 16 Gm Dm F B \flat
 with the__ mouth one con - fes - ses and is saved.
 19 Dm E \flat F B \flat
 Ro - mans Ten, nine through ten.

Words: adapted from Romans 10:9-10 ESV Music: Constance Dever ©2012

In My Father's House

In my Fath-er's house are ma - ny rooms," Je - sus
 said. "I go pre - pare, pre-prepare a place for you. You know the
 way." "Lord, we don't know where you are go - ing," Thom - as said to
 him. "Lord, we don't know where you are go - ing, How can we know the
 way?" "I am the Way, I am the Truth, I am the Life," Je - sus an swered. "I am the
 Way, I am the Truth, I am the Life," Je - sus an - swered. "No one can come to the
 Fa - ther, ex-cept through me." John Four-teen, two thro' six.

Words: adapted from John 14:2-6, ESV Music: Constance Dever ©2012

Unit 11 Bible Truth 3 Bible Verse Song Lyrics

**Bible Verse Song:
He Saved Us**

DDD ESV Songs 11, Track 21

He saved us, he saved us,
By regeneration
And renewal of the Spirit.
He saved us, he saved us,
By the Holy Spirit.

The Holy Spirit whom he poured out,
On us richly,
Through Jesus Christ our Lord,
The Holy Spirit whom he poured out,
On us, through Jesus Christ.
Titus Three, verses five through seven.

about this Bible verse:

Words: Titus 3:5-7, ESV Music: Constance Dever ©2012

We can never please God with our own, good works. Only through Jesus' perfect life offered up in the place of sinners can we be saved. And what a salvation it is! God, Himself, sends His Holy Spirit to work in the hearts of His people. He gives them the gift of faith. He helps them turn away from their sins. He makes them clean of their sins and all new on the inside. This is how we, too, can become God's people--His heirs; that is, His children who will receive eternal life and live with Him forever.

Unit 11 Bible Truth 3 Bible Verse Song Lyrics

Extra Bible Verse Song:

DDD ESV Songs 11, Track 22

I Will Give You a New Heart

I will give you a new heart,
And a new spirit, I will put within you.
I will give you a new heart,
And a new spirit, I will put within you.
Ezekiel Thirty-six, twenty-six.

about this Bible verse:

Words: Ezekiel 36:26, ESV Music: Constance Dever ©2012

God, Himself, has promised to give His people the new heart they need. He works in their hearts as they hear His Word. He helps them to see that they are sinners and helps them to turn away from their sins and trust in Jesus as their Savior. He fills their heart with His Spirit, making it new--full of more and more knowledge of Him, love for Him and trust in Him. This is how God builds and grows His church: from the inside out, one heart at a time!

He Saved Us

F
C
F

He saved us, He sav - ed us, by re - ge - ner - a - tion, and re - new - al of the Spir - it. He

5
C
F

saved us, He sav - ed us, by the Ho - ly Spir - it. The Ho - ly Spir - it whom

10
C
F

He poured out on us rich - ly through Je - sus Christ our Lord, The Ho - ly Spir - it whom

14
C
F
C
F

He poured out on us through Je - sus Christ. Ti - tus Three, ver - ses five thru' se - ven.

Words: adapted from Titus 3:5-7, ESV Music: Constance Dever ©2012

I Will Give You a New Heart

F C C(add4) Bb Bb C Bbmaj7 1. C F



I will give you a new heart, and a new spi-rit I will put with - in you.

5 2. C F Bb F C F

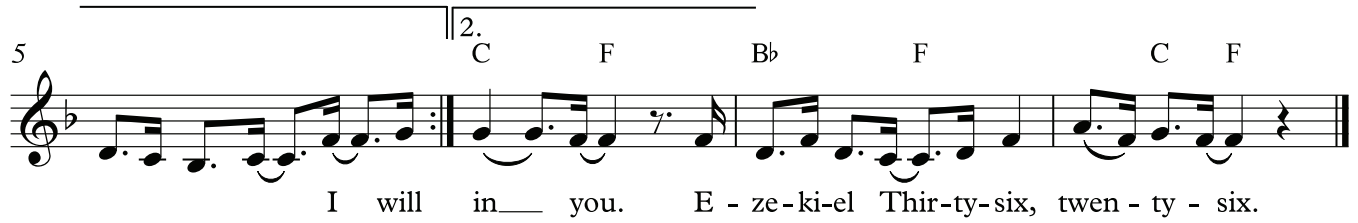

I will in__ you. E - ze-ki-el Thir-ty-six, twen - ty - six.

Words: adapted from Ezekiel 36:26, ESV Music: Constance Dever ©2016

DEEP DOWN DETECTIVES

Curriculum Resources



**Appendix B:
Games**

Index of Games

List of Supplies Needed to Make All Games	163
Bible Verse Games	
Duck, Duck, Goose	167
Slap, Clap and Stack	168
Simon Says How	169
Roll 'n' Toss	170
Block Clapping	171
Meet, Greet and Keep It Up	172
Bean Bag Catch	173
Animal Cube	174
Fill 'er Up	175
Lily Pad Jump	176
Loud and Soft, Big and Little	177
Freeze 'n' Say	178
Detective Mission Madness Practice	179
Music, Movement & Memory Activities	
Thumping Drums	180
Say, Spring Up and Shout	181
Freeze Frame	182
Egg Shakers	183
Jingle Bell Hands	184
Big Voice, Little Voice	185
Sing, Dance and Fall Down	186
Bottle Shakers	187
March 'n' Say	188
Clap, Tap and Say	189
Block Clappers	190
Lullabies, Bells and Lions	191
Musical Squares	192
Bible Story Review Games	
Take Me through the Tunnel	193
Missing in Action	194
Treasure Hunt	195
Look Who's Coming Down the Tracks	196
Can You Remember?	197
Clothespin Line Up and Drop	198
Deep Down Detective Clue Hunt	199
Run to the Grocery Store	201
Who's in the Basket?	202
Going Fishing	203
Pony Express	204
Who's Inside?	205
Fix Up the Mix Up	206

Master Supplies List for All Deep Down Detectives Games

Deep Down Detectives uses many games. The good news is, they are simply made and they are re-used throughout the whole curriculum. Make sure you save the games you make and it will save you a lot of time later.

This is the full list of the games and the supplies needed in the Deep Down Detectives Curriculum. I **would highly suggest you do this!** Get the prep work over with at the beginning and coast your way through years of enjoyment! Store them in ziploc bags or baskets and pull them out when needed. So simple!

THIS LIST IS ALSO INCLUDED IN INTRODUCTION

Bible Verse Games

Lily Pad Jump

- Cube-shaped cardboard box,
- paper,
- glue,
- marker

Animal Cube

- Cube-shaped cardboard box,
- paper,
- glue,
- marker

Simon Says How

- Cube-shaped Cardboard box
- Paper, glue, and a marker

Bean Bag Catch

- 1 bean bag per every 2 children (or every child)
- NOTE: Can also fill socks with beans and tie open end to make beanbags.

Slap, Clap and Stack

- 10 or 12 Blocks or other stackable objects

Freeze 'n' Say

- Music and CD/Tape player

Fill'er Up

- 1 bean bag per child
- NOTE: Can also fill socks with beans and tie open end to make beanbags.
- Cardboard box or laundry basket
- Carpet squares, 1 per child

Loud and Soft, Big and Little

- none

Bible Verse Games

Roll 'n' Toss

- Cube-shaped Cardboard box
- Paper, glue, and a marker
- 1 bouncy ball per 2 children

Duck, Duck, Goose

- none

Deep Down Detective Mission Madness Practice

- Detective Gear, such as a trench coat, sunglasses, and a hat

Block Clapping

- 2 wooden blocks per child, preferably about 3"x 2", as found in many children's block sets

Meet, Greet, and Keep It Up

- 16 oz cups, 1 per child (with some extras)
- 2 pieces of rope as long as a line of children
- Masking tape

Master Supplies List for All Deep Down Detectives Games, continued

Music, Movement & Memory

Thumping Drums

- 1 Oatmeal container/coffee can with lid per drum.
- Tape
- Popcorn, rice, beans, etc.
- Wooden spoons, dowels, unsharpened pencils, if desired, for mallets

Say, Spring Up and Shout

- Bean bags, one per child

Freeze Frame

- Some kind of fun hat or clothing for the leader to wear

Egg Shakers

- Empty Easter eggs
- Rice, beans, buttons, pennies, popcorn, beads, small nails or bolts, etc.
- Glue and glue gun OR strong packing tape

Jingle Bell Hands

- 1 6" piece of sturdy string
- 4 or 5 jingle bells, available in most craft shops

Sing, Dance, and Fall Down

- Optional: Bean bags, one per child

Big Voice, Little Voice

- none

Bottle Shakers

- 1 empty 16 oz. soda bottle per shaker
- Rice, beans, buttons, pennies, popcorn, beads, small nails or bolts, etc.
- Glue and glue gun OR strong packing tape

March 'n' Say

- Optional: A fun hat for the leader of the march, or for everyone in the march

Clap, Tap and Say

- none

Lullabies, Bells and Lions

- Bell

Music, Movement & Memory

Musical Squares

- Carpet Squares, enough for all of the children (or chairs)

Block Clappers

- 2 wooden blocks per child, preferably about 3"x 2", as found in many children's block sets

Master Supplies List for All Deep Down Detectives Games, continued

Story Review Games

Going Fishing

- One long wooden dowel, yardstick, etc. per fishing pole
- Yarn
- Paper clip per fishing pole
- Rope
- Two chairs
- Blanket
- Box/bucket/container
- Bucket

Pony Express

- Small manila envelopes, one per flannel graph figure
- Kid's small backpack or a tote bag with a strap
- Basket
- Cowboy hat
- Stick horse or a broom

Fix Up the Mix Up

- None

Can You Remember?

- Index cards

Deep Down Detectives Clue Hunt

- Variety of interesting items that have one or more places to hide a storyboard picture
- Detective Hat
- 4 False Clues (included on the next page)
- CD Player and Deep Down Detectives Theme Song

Clothespin Line Up and Drop

- Rope
- Clothespins, the hinged type
- Shoe box
- Tape

Who's in the Basket?

- Blanket
- Basket

Run to the Grocery Store

- Grocery bag or kid's grocery cart
- Empty food cartons

Story Review Games

Treasure Hunt

- 10 small lidded plastic containers or boxes (like from a jewelry store) or wooden, hinged boxes from a craft store
- Various decorating supplies, such as fake craft jewels, glitter, glitter glue, foil paper, gold spray paint
- glue

Take Me Through the Tunnel

- Chairs or Table
- Sheet or blanket
- Box

Missing in Action

- None

Who's Inside?

- 10 different containers with lids

Look Who's Coming Down the Tracks

- Two shoe boxes
- 6' or so of rope
- Optional: Engineer's hat

Bible Verse Game

intake or Response Activity to learn Bible verse

Duck, Duck, Goose

Materials

- Bible Verse sign from the curriculum
- Deep Down Discussion Questions (optional)

Preparation

None.

Learning the Verse

Choose the whole verse or an appropriate length portion of the verse to learn. Read the verse slowly and explain it to them. A simple explanation is included on the back of the Bible Truth sign. Practice saying the verse with the children a few times.

Playing the Game

1. Have the children sit in a circle, cross-legged on the floor.
2. Choose a child to be "It". "It" will walk around behind the seated children, tapping each one on the head, the whole group recites the verse, saying one word for each head tap.
3. The child whose head is the last one to be tapped must get up and chase "It", hoping to tag "It" before "It" can get around the circle and sit down in the open spot in the circle.
4. If the child does tag "It" then he may take his place in the circle. If not, then the new child is "It." If desired, you can also ask them a question about the verse before repeating. See the Deep Down Discussion Sheet for possible questions.
5. Repeat as frequently as desired.

Bible Verse Game

intake or Response Activity to learn Bible verse

Slap, Clap and Stack

Materials

- Bible Verse sign from the curriculum
- Deep Down Discussion Questions (optional)
- 10 or 12 Blocks or other stackable objects

Preparation

None.

Learning the Verse

Choose the whole verse or an appropriate length portion of the verse to learn. Read the verse slowly and explain it to them. A simple explanation is included on the back of the Bible Truth sign. Practice saying the verse with the children a few times.

Playing the Game

1. Tell the children that they are going to learn the verse while working together to make the largest stack of blocks/objects they can. After each time they say the verse, a child gets to pick out an object to put on the tower. Teacher will help them balance it in place.
2. Have everyone sit down in a circle around the stacking area. Say the verse together. If desired, you can add a motion the children do each time they say the verse, such as clap, stomp feet, etc. This will add movement to this game. Choose a child to pick out an object. Help the child put it in place.
3. Continue adding objects/blocks until all objects are used up or the tower falls down.
4. Repeat as desired. If desired, you can also ask them a question about the verse after every turn or every few turns. See the Deep Down Discussion Sheet for possible questions.

Bible Verse Game

intake or Response Activity to learn Bible verse

Simon Says How

Materials

- Bible Verse sign from the curriculum
- Deep Down Detectives Discussion Questions (optional)
- Cube-shaped Cardboard box
- Paper, glue, and a marker
- Die Number and Action Chart (see below)

Preparation

Make a die out of the cardboard box as follows:

1. Cut the paper into the size of one side of the cube. Use it as a pattern to make six pieces (one for each side of the cube)
2. Glue each piece of paper onto each side of the cube.
3. Write the numbers 1-6 on the each side of the cube like a die.
4. Make a sign as follows:

1 = Head	2 = Feet
3 = Hands	4 = Hands and Feet
5 = Laying Down	6 = Eyes Closed

Learning the Verse

Choose the whole verse or an appropriate length portion of the verse to learn. Read the verse slowly and explain it to them. A simple explanation is included on the back of the Bible Truth sign. Practice saying the verse with the children a few times.

Playing the Game

1. Have the children spread out facing the leader.
2. Tell the children that they are going to play "Simon Says How", a game in which everyone will take turns making up different actions that they will do while saying the verse.
3. Explain that "Simon" will roll the die and make up actions that use the parts of the body that correspond to the number on the chart. Everyone else will then recite the verse while standing still. Then challenge them to recite it again while doing the actions "Simon" made up at the same time.
4. Simon will then choose another person to be Simon in his place. Repeat. If desired, you can also ask them a question about the verse after every turn or every few turns. See the Deep Down Detectives Discussion Sheet for possible questions.

Bible Verse Game

intake or Response Activity to learn Bible verse

Roll 'n' Toss

Materials

- Bible Verse sign from the curriculum
- Deep Down Discussion Questions (optional)
- Cube-shaped Cardboard box
- Paper, glue, and a marker
- 1 bouncy ball per 2 children

Preparation

1. Cut the paper into the size of one side of the cube. Use it as a pattern to make six pieces (one for each side of the cube)
2. Glue each piece of paper onto each side of the cube.
3. Write different actions on each side of the cube: Roll, Bounce, Overhand Toss, Close Eyes and Roll, Backwards Roll (through legs), Underhand Toss.

Learning the Verse

Choose the whole verse or an appropriate length portion of the verse to learn. Read the verse slowly and explain it to them. A simple explanation is included on the back of the Bible Truth sign. Practice saying the verse with the children a few times.

Playing the Game

1. Have the children spread out facing the leader.

Playing the Game

1. Tell the children they will be throwing a ball to a partner in the different ways you have written on the cube (show them the cube).
2. Have the children stand in two long lines, with their partners facing each other about 9-12' apart (whatever seems to be a good tossing/rolling distance for your children).
3. Give out the ball to each person in one of the long lines. (Partners will not have one.)
4. Practice each of the different ball actions, then begin the game.
5. Have everyone say the verse together. Toss the cube and tell everyone what the motion will be. At your signal, have one partner roll, toss, etc. the ball to the other. After all the partners have received the balls and everyone is back in line. Have everyone say the verse together, then toss the cube again. If desired, you can also ask them a question about the verse after every few rolls. See the Deep Down Discussion Sheet for possible questions.

Bible Verse Game

intake or Response Activity to learn Bible verse

Block Clapping

Materials

- Bible Verse sign from the curriculum
- Deep Down Discussion Questions (optional)
- 2 wooden blocks per child, preferably about 3"x 2", as found in many children's block sets

Preparation

None.

Learning the Verse

Choose the whole verse or an appropriate length portion of the verse to learn. Read the verse slowly and explain it to them. A simple explanation is included on the back of the Bible Truth sign. Practice saying the verse with the children a few times.

Playing the Game

1. Show the children the clapping blocks and tell them: "We are going to use our Bible verse to play a game. But first, we need to practice saying the verse." (Practice saying it a couple of times).
2. Hand out the clapping blocks and let the children clap them a while (without saying the verse), then quiet them.
3. Then tell them, "OK, let's try saying our verse and block clapping at the same time!" Lead the children in reciting the verse and clapping with each word. Or, you can have the children clap the blocks together a certain number of times, then say the verse after the last clap. If desired, you can also ask them a question about the verse before repeating. See the Deep Down Discussion Sheet for possible questions.
4. Repeat as frequently as desired.

Bible Verse Game

intake or Response Activity to learn Bible verse

Meet, Greet and Keep It Up

Materials

- Bible Verse sign from the curriculum
- Deep Down Discussion Questions (optional)
- 16 oz. cups, 1 per child (with some extras)
- 2 pieces of rope as long as a line of children
- Masking tape

Preparation

1. Line up the 2 pieces of rope about 6' apart.
2. Put down a piece of masking tape the same length as the ropes, running parallel to the ropes midway between the 2 ropes.

Learning the Verse

Choose the whole verse or an appropriate length portion of the verse to learn. Read the verse slowly and explain it to them. A simple explanation is included on the back of the Bible Truth sign. Practice saying the verse with the children a few times.

Playing the Game

1. Split the children into partners. Have them stand in two long lines, with their partners facing each other about 6' apart.
2. Tell the children they will be meeting and greeting their partners with a handshake at the masking tape in the middle, then turning around and going back to their place along the rope. Have them practice this.
3. Now tell them, that they will also be balancing a cup on their head while they do this.
4. Give out a cup to everyone. Have them practice balancing the cup on their heads.
5. Now play the game. Have everyone say the verse together. Then have them put the cups on their heads. At your signal, have them walk to the middle, greet their partner with a handshake, turn around and go back—trying to keep the cup balanced on their head the whole time. (There is no penalty for cups falling off.)
6. Have everyone settle back in place in the line, with the cups off their heads. Say the verse together again, put the cups back on their heads, then walk to greet partner again, etc.
7. You can move the ropes back gradually so the children can try to do it from further and further apart.
8. If desired, you can also ask them a question about the verse after every few turns. See the Deep Down Detective Discussion Sheet for possible questions.

Bible Verse Game

intake or Response Activity to learn Bible verse

Bean Bag Catch

Materials

- Bible Verse sign from the curriculum
 - Deep Down Discussion Questions (optional)
 - 1 bean bag per every 2 children (or every child)
- NOTE: Can also fill socks with beans and tie open end to make beanbags.

Preparation

None.

Learning the Verse

Choose the whole verse or an appropriate length portion of the verse to learn. Read the verse slowly and explain it to them. A simple explanation is included on the back of the Bible Truth sign. Practice saying the verse with the children a few times.

Playing the Game

1. Pair the children with a partner.
2. Have the children stand in two long lines, with their partners facing each other at arm's length apart.
3. Give out a bean bag to each person in one of the long lines. (Partners will not have one.) Have everyone say the verse together, then throw the bean bag to their partners, trying to catch the bean bag. (NOTE: no one is "out" if they don't catch it.)
4. Have both lines of children take a step back.
5. Say the verse altogether again, then throw the bean bags again.
6. Repeat as frequently as desired. If desired, you can also ask them a question about the verse after every turn or every few turns. See the Deep Down Discussion Sheet for possible questions.

Bible Verse Game

intake or Response Activity to learn Bible verse

Animal Cube

Materials

- Bible Verse sign from the curriculum
- Deep Down Discussion Questions (optional)
- Cube-shaped cardboard box
- Paper, glue, and a marker

Preparation

1. Cut the paper into the size of one side of the cube. Use it as a pattern to make six pieces (one for each side of the cube) Draw a simple animal picture on each piece of paper. Possibilities would be: rabbit, monkey, elephant, bird, fish, and a horse. Glue each picture onto each side of the cube.

Learning the Verse

Choose the whole verse or an appropriate length portion of the verse to learn. Read the verse slowly and explain it to them. A simple explanation is included on the back of the Bible Truth sign. Practice saying the verse with the children a few times.

Playing the Game

1. Tell the children they will be playing a game in which they must move like six different animals. Have them practice the movements for each of the animals on your cube. (Rabbit: leaping; monkey: scratching under arms and saying "ooh-ooh, ahh-ahh"; Elephant: swinging arms like a trunk and making trumpet sound; Bird: flapping arms like wings; Fish: palms together, weaving them in a serpentine action, saying "blub-blub"; horse: galloping/prancing and neighing).
2. Show the children the cube with the animal pictures on it, just like the ones they've practiced. Tell them that you will roll the dice and everyone (at your signal) will begin making the movement for that animal. Tell them that they must stop in place and be very quiet when they hear a certain noise (such as a whistle, a bell ring, clap, etc.). Tell them that you will be watching them. And that children who are very good at listening and stopping when you say so will get a chance to toss the cube for everyone. Practice tossing the cube, making the movements and stopping with the children.
3. Now it's time to play the whole game. Choose a child to roll the cube and say which animal is picked and what action they will do for the animal. Have everyone say the verse, then at your cue, let the children act out the animal until you tell them to stop (a bell or whistle can be used to give the start and stop signals).
4. Choose another child and repeat. If desired, you can also ask them a question about the verse after every turn or every few turns. See the Deep Down Discussion Sheet for possible questions.

Other Option: If children get really good at this, you can challenge them by saying the verse while they make the movement.

Bible Verse Game

Intake or Response Activity to learn Bible verse

Fill 'er Up

Materials

- Bible Verse sign from the curriculum
- Deep Down Discussion Questions (optional)
- 1 Bean bag per child
- NOTE: Can also fill socks with beans and tie open end to make beanbags.
- Cardboard box or laundry basket
- Carpet squares, 1 per child

Preparation

1. Put box/basket in a central location.
2. Place carpet squares equidistant about 2' from center box/basket. These will be for the children to sit on.

Learning the Verse

Choose the whole verse or an appropriate length portion of the verse to learn. Read the verse slowly and explain it to them. A simple explanation is included on the back of the Bible Truth sign. Practice saying the verse with the children a few times.

Playing the Game

1. Have the children stand on a carpet square.
2. Tell them that they will be saying the verse, then—on your signal—they will try to throw as many of their bean bags as they can into the box/basket target in the middle.
3. As they get good at throwing their bean bags in, have the children move back their carpet squares.
4. Repeat verse before toss. If desired, you can also ask them a question about the verse after every few tosses. See the Deep Down Discussion Sheet for possible questions.

Bible Verse Game

intake or Response Activity to learn Bible verse

Lily Pad Jump

Materials

- Bible Verse sign from the curriculum
- Deep Down Discussion Questions (optional)
- Cube-shaped cardboard box, paper, glue, marker

Preparation

Make a die out of the cardboard box as follows:

1. Cut the paper into the size of one side of the cube.
2. Use it as a pattern to make six pieces (one for each side of the cube).
3. Glue each piece of paper onto each side of the cube.
4. Write the numbers 1-6 on the each side of the cube like a die.

Learning the Verse

Choose the whole verse or an appropriate length portion of the verse to learn. Read the verse slowly and explain it to them. A simple explanation is included on the back of the Bible Truth sign. Practice saying the verse with the children a few times.

Playing the Game

1. Tell children that they will be froggies, leaping from lily pad to lily pad. Everyone will say the verse together, then you (or a very good, well-behaved listening "froggie") will roll the die and see how many leaps all the froggies will make before them stop.
2. Have them practice leaping. Warn them to watch out for their other froggie friends so that no one gets hurt. Practice stopping.
3. Have everyone get in froggie position. Roll die and tell them how many leaps they will leap. Say the verse together. At your signal, everyone leaps as you (or you and they) count out the number of leaps together: "1, 2, 3, stop!" etc. Repeat. If desired, you can also ask them a question about the verse after every turn or every few turns. See the Deep Down Discussion Sheet for possible questions.

Bible Verse Game

intake or Response Activity to learn Bible verse

Loud and Soft, Big and Little

Materials

Bible Verse sign from the curriculum
Deep Down Discussion Questions (optional)

Preparation

None.

Learning the Verse

Choose the whole verse or an appropriate length portion of the verse to learn. Read the verse slowly and explain it to them. A simple explanation is included on the back of the Bible Truth sign. Practice saying the verse with the children a few times.

Playing the Game

1. Tell the children: "Let's practice our Bible verse with a game."
2. "First let's say our verse together," (say it a couple times).
3. "Now let's see how quietly we can whisper it! Can you say it quietly like I am?" Have everyone follow your voice as it gets quiet, then loud, then medium, etc. Quiet them, then repeat. If desired, you can also ask them a question about the verse after they repeat the verse a few times. See the Deep Down Discussion Sheet for possible questions.

NOTE: You may find it easier for the children to follow getting louder and softer by lowering your hands when you are getting quieter and then raising your hands when you are getting louder.

Bible Verse Game

intake or Response Activity to learn Bible verse

Freeze 'n' Say

Materials

- Bible Verse sign from the curriculum
- Deep Down Discussion Questions (optional)
- Music and CD/Tape player

Preparation

None.

Learning the Verse

Choose the whole verse or an appropriate length portion of the verse to learn. Read the verse slowly and explain it to them. A simple explanation is included on the back of the Bible Truth sign. Practice saying the verse with the children a few times.

Playing the Game

1. Play some of the music for the children. Tell them that they will move around the room as you tell them (marching, leaping, clapping, etc.) while they hear the music. They will stop and freeze in whatever position they are in when the music stops. Practice this with them.
2. When they have the concept down, add saying the verse when the music stops and they are in their frozen position.
3. After they say the verse, then tell them how you want them to move when the music starts again. You can take their suggestions for movement ideas, too.
4. Start the music up again and continue. Repeat as frequently as desired. If desired, you can also ask them a question about the verse after every turn or every few turns. See the Deep Down Discussion Sheet for possible questions.

Bible Verse Game

Intake or Response Activity to learn Bible verse

Deep Down Detectives Mission Madness Practice

Materials

- Bible Verse sign from the curriculum
- Deep Down Discussion Questions (optional)
- Deep Down Detectives Theme Song and/or Bible verse song
- Detective Gear, such as a trench coat, sunglasses, and a hat

Preparation

None.

Learning the Verse

Choose the whole verse or an appropriate length portion of the verse to learn. Read the verse slowly and explain it to them. A simple explanation is included on the back of the Bible Truth sign. Practice saying the verse with the children a few times.

Playing the Game

1. Tell the children that sometimes detectives have to do all sorts of things to get answers to their questions and solve the case they are working on. In this game, they will practice some detective moves.
2. Put on the detective costume, telling the children that you will start out the game as the Chief Detective.
3. As you play the Deep Down Detectives theme song, you will lead the children in practicing one of their moves, such as swimming across a deep river. . (Other possible actions would be crawling, hand over eye looking around left and right; walking backwards, shuffling, stooping, and crawling..)
4. When the song finishes, the children will sit down and everyone will say the verse together. If desired, you can also ask them a question about the verse. See the Deep Down Discussion Sheet for possible questions.
5. Choose a child to take your place as Chief Detective. Repeat activity, choosing another detective move. Play continues as time and attention span allow.

Music, Movement & Memory Activity

Intake or Response Activity to learn the Big Question, Bible verse and Unit music

Thumping Drums

Materials

- CD of unit music
- Deep Down Detectives Discussion Questions (optional)
- 1 Oatmeal container/coffee can with lid per drum.
- Tape
- Popcorn, rice, beans, etc.
- Wooden spoons, dowels, unsharpened pencils, if desired, for mallets

How to Make

1. Tape the lid of empty oatmeal or coffee cans in place. (If want to make a snare drum, add popcorn, rice, etc. in the empty container before taping shut.)
2. Children can either tap drum with hands or you can give them 2 wooden spoons, wooden dowels or unsharpened pencils with wooden spoons glued to an end as mallets.

What to Do

1. Show the children the thumping drums. Tell them. "I'm going to say God's Word and make a joyful noise to Him with these thumping drums. Come and join me!"
2. First let's sing our Bible verse song/Big Question song/Praise Song/Hymn together (say the verse a couple of times, if using it.)
3. "Now let's make that joyful noise to the LORD!" Hand out the drums (and mallets) and let the children beat them awhile. Quiet them, then repeat.
4. If desired, you can ask the children a question related to the verse/the songs they are singing, using the Deep Down Detectives Discussion Sheet after each time (or every few times) you sing the song/say the verse.

NOTE: Younger children may need to sing the Bible verse/Big Question song/etc, then thump. But, as the children get older, they may be able to sing the song(s) AND thump at the same time.

Music, Movement & Memory Activity

Intake or Response Activity to learn the Big Question, Bible verse and Unit music

Say, Spring Up and Shout

Materials

- CD of unit music
- Deep Down Detectives Discussion Questions (optional)
- Optional: Bean bags, one per child

What to Do

1. Tell the children: "We're going to sing our Bible verse/Big Question/other song and make a joyful noise to God, crouching down like this (Crouch down). Then at the end, we're going to spring up and shout, "Amen, I agree!"
2. First let's sing our Bible verse song/Big Question song/Praise Song/Hymn together (say the verse a couple of times, if using it.)
3. "Now let's jump up and say, "AMEN! I agree!" After everyone springs up and says "Amen," quiet them, then repeat.
4. If desired, when the children get the crouching and jumping down, you might give them a bean bag to toss in the air as they spring up. Practicing tossing up in the air rather than AT others.
5. If desired, you can ask the children a question related to the verse/the songs they are singing, using the Deep Down Detectives Discussion Sheet after each time (or every few times) you sing the song/say the verse.

Music, Movement & Memory Activity

Intake or Response Activity to learn the Big Question, Bible verse and Unit music

Freeze Frame

Materials

- CD of unit music
- Deep Down Detectives Discussion Sheet Questions (optional)
- Some kind of fun hat or clothing for the leader to wear

What to Do

1. Tell the children. "I'm going to sing God's Word and make a joyful noise to Him...but I'm going to freeze in place in between songs. Come and join me!"
2. Choose one child to be the leader. Help them put on the leader hat/clothing.
3. Have the kids march around behind the leader, singing the song of your choice.
4. Have the children freeze in place when you stop the song at a random point.
5. When everyone is frozen, have the children tell you what the next word/phrase to the song.
6. If desired, you can ask the children a question related to the words or another question from the Deep Down Detectives Discussion Sheet after each time (or every few times) you freeze the song.
7. Choose another leader and play the song again, stopping on a different word from the song to highlight.

Music, Movement & Memory Activity

Intake or Response Activity to learn the Big Question, Bible verse and Unit music

Egg Shakers

Materials

- CD of unit music
- Deep Down Detectives Discussion Sheet (optional)
- Empty Easter eggs
- Rice, beans, buttons, pennies, popcorn, beads, small nails or bolts, etc.
- Glue and glue gun OR strong packing tape

How to Make

1. Fill empty Easter eggs with different small objects such as rice, beans, pennies, buttons, popcorn, beads, small nails or bolts, etc., then seal lid shut with glue gun or with packing tape. Different objects make different sounds. Different amounts of the same object make different sounds, too. The children will enjoy the variety.

What to Do

1. Show the children the egg shakers and tell them, "I'm going to sing our Bible verse/Big Question/other song and make a joyful noise to God with these egg shakers. Come and join me!"
2. First let's sing our Bible verse song/Big Question song/Praise Song/Hymn together (say the verse a couple of times, if using it.)
3. Hand out the egg shakers and let the children shake them a while (without singing), then quiet them.
4. Then tell them, "OK, let's try singing and shaking our eggs at the same time!" Lead the children in song and shaking.
5. If desired, you can ask the children a question related to the verse/the songs they are singing, using the Deep Down Detectives Discussion Sheet after each time (or every few times) you sing the song/say the verse.

NOTE: Younger children may need to sing the Bible verse/Big Question song/etc, then shake. But, as the children get older, they may be able to sing the song(s) AND shake at the same time.

Music, Movement & Memory Activity

Intake or Response Activity to learn the Big Question, Bible verse and Unit music

Jingle Bell Hands

Materials

- CD of unit music
- Deep Down Detectives Discussion Questions (optional)
- 1 6" piece of sturdy string
- 4 or 5 jingle bells, available in most craft shops (OR three Ball jar lid outer rings per instrument)

How to Make

1. Cut a piece of string about 6" long.
2. Thread 4 or 5 jingle bells onto string, securely tying each in place with a knot before adding the next one. Tie the ends together. Children can either wear these like a bracelet or can hold them in their hands. If using Ball jar lid rings, string three of these together with the same piece of string and fasten.

What to Do

1. Show the children the bottle shakers and tell them, "I'm going to sing our Bible verse/Big Question song and make a joyful noise to God with these bottle shakers. Come and join me! First, let's sing the Bible verse/ Big Question/etc. song together on our own (sing the song a couple of times.) Now let's make that joyful noise to the LORD!"
2. Hand out the jingle hand bells and let the children jingle them a while (without singing), then quiet them.
3. Then tell them, "OK, let's try singing and jingling at the same time!" Lead the children in singing and jingling.
4. If desired, you can ask the children a question related to the verse/the songs they are singing, using the Deep Down Detectives Discussion Sheet after each time (or every few times) you sing the song/say the verse.

NOTE: Younger children may need to sing the Bible verse/Big Question song/etc, then jingle. But, as the children get older, they may be able to sing the song(s) AND jingle at the same time.

Music, Movement & Memory Activity

Intake or Response Activity to learn the Big Question, Bible verse and Unit music

Big Voice, Little Voice

Materials

- CD of unit music
- Deep Down Detectives Discussion Questions (optional)

What to Do

1. Tell the children: "I'm going to sing our Bible verse/Big Question song and make a joyful noise to Him quietly and loudly! Come and join me!"
2. First let's sing our Bible verse song/Big Question song/Praise Song/Hymn together (say the verse a couple of times, if using it.)
3. "Now let's see how quietly we can whisper it! Can you sing it quietly like I am?" Have everyone follow your voice as it gets quiet, then loud, then medium, etc. Quiet them, then repeat.
4. If desired, you can ask the children a question related to the verse/the songs they are singing, using the Deep Down Detectives Discussion Sheet after each time (or every few times) you sing the song/say the verse.

NOTE: You may find it easier for the children to follow getting louder and softer by lowering your hands when you are getting quieter and then raising your hands when you are getting louder.

Music, Movement & Memory Activity

Intake or Response Activity to learn the Big Question, Bible verse and Unit music

Sing, Dance and Fall Down

Materials

- CD of unit music
- Deep Down Detectives Discussion Questions (optional)
- 1 oatmeal container/coffee can with lid per drum.
- Tape
- Popcorn, rice, beans, etc.
- Wooden spoons, dowels, unsharpened pencils, if desired, for mallets

How to Make

1. Tape the lid of empty oatmeal or coffee cans in place. (If want to make a snare drum, add popcorn, rice, etc. in the empty container before taping shut.)
2. Children can either tap drum with hands or you can give them 2 wooden spoons, wooden dowels or unsharpened pencils with wooden spools glue gunned to an end as mallets.

What to Do

1. Tell the children: "I'm going to sing our Bible verse/Big Question/etc. song and make a joyful noise to Him with my body by dancing to some music...then falling down when it stops. Come and join me!"
2. First let's sing our Bible verse song/Big Question song/Praise Song/Hymn together (say the verse a couple of times, if using it.)
3. "Now let's dance as we sing our song. Then fall down when we finish. Let's dance." Have everyone dance and sing the song. When you finish, say, "Everyone fall down!" Quiet the children, then repeat.
4. If desired, you can ask the children a question related to the verse/the songs they are singing, using the Deep Down Detectives Discussion Sheet after each time (or every few times) you sing the song/say the verse.

Music, Movement & Memory Activity

Intake or Response Activity to learn the Big Question, Bible verse and Unit music

Bottle Shakers

Materials

- CD of unit music
- Deep Down Detectives Discussion Questions (optional)
- 1 empty 16 oz. soda bottle per shaker
- Rice, beans, buttons, pennies, popcorn, beads, small nails or bolts, etc.
- Glue and glue gun OR strong packing tape

How to Make

1. Fill empty 16 oz.. soda bottles with different small objects such as rice, beans, pennies, buttons, popcorn, beads, small nails or bolts, etc.
2. Seal lid shut with glue gun or with packing tape. Different objects make different sounds. Different amounts of the same object make different sounds, too. The children will enjoy the variety.

What to Do

1. Show the children the bottle shakers and tell them. "I'm going to sing our Bible verse/Big Question song and make a joyful noise to God with these bottle shakers. Come and join me! First, let's sing the Bible verse/ Big Question/etc. song together on our own (sing the song a couple of times.) Now let's make that joyful noise to the LORD!"
2. Hand out the bottle shakers and let the children shake them a while (without singing), then quiet them.
3. Then tell them, "OK, let's try singing and shaking at the same time!" Lead the children in song and shaking.
4. If desired, you can ask the children a question related to the verse/the songs they are singing, using the Deep Down Detectives Discussion Sheet after each time (or every few times) you sing the song/say the verse.

NOTE: Younger children may need to sing the Bible verse/Big Question song/etc, then shake. But, as the children get older, they may be able to sing the song(s) AND shake at the same time.

Music, Movement & Memory Activity

Intake or Response Activity to learn the Big Question, Bible verse and Unit music

March 'n' Say

Materials

- CD of unit music
- Deep Down Detectives Discussion Questions (optional)
- Optional: A fun hat for the leader of the march, or for everyone in the march

What to Do

1. Tell them, "I'm going to say God's Word and make a joyful noise to Him by marching. Come and join me!"
2. First let's sing our Bible verse song/Big Question song/Praise Song/Hymn together (say the verse a couple of times, if using it.)
3. "Now let's march around as we sing!"
4. If desired, let the leader of the march (you the first time, then pick different children), wear a fun hat as he/she leads. Or, have hats for everyone to wear.
5. If desired, you can ask the children a question related to the verse/the songs they are singing, using the Deep Down Detectives Discussion Sheet after each time (or every few times) you sing the song/say the verse.

NOTE: Younger children may need to sing the Bible verse/Big Question song/etc, then thump. But, as the children get older, they may be able to sing the song(s) AND thump at the same time.

Music, Movement & Memory Activity

Intake or Response Activity to learn the Big Question, Bible verse and Unit music

Clap, Tap and Say

Materials

- CD of unit music
- Deep Down Detectives Discussion Questions (optional)

What to Do

1. Tell the children: "I'm going to sing our Bible verse/Big Question/etc. song and make a joyful noise to Him with my body by clapping and tapping. Come and join me!"
2. First let's sing our Bible verse song/Big Question song/Praise Song/Hymn together (say the verse a couple of times, if using it.)
3. "Now let's clap and tap! Can you do what I'm doing?" Have everyone follow your motions as you clap your hands, tap your head, hit your knees together, rub your belly, etc. for a while. Quiet them, then repeat. If desired, have different children think up different motions.
4. If desired, you can ask the children a question related to the verse/the songs they are singing, using the Deep Down Detectives Discussion Sheet after each time (or every few times) you sing the song/say the verse.

NOTE: Younger children may need to sing the Bible verse/Big Question song/etc, then clap, tap, etc. But, as the children get older, they may be able to sing the song(s) AND do the motions at the same time.

Music, Movement & Memory Activity

Intake or Response Activity to learn the Big Question, Bible verse and Unit music

Block Clappers

Materials

- CD of unit music
- Deep Down Detectives Discussion Questions (optional)
- 2 wooden blocks per child, preferably about 3"x 2", as found in many children's block sets

What to Do

1. Show the children the clapping blocks . Tell them, "I'm going to say God's Word and make a joyful noise to Him with these clapping blocks. Come and join me!
2. First let's sing our Bible verse song/Big Question song/Praise Song/Hymn together (say the verse a couple of times, if using it.)
3. Now let's make that joyful noise to the LORD!" Hand out the clapping blocks and let the children clap them a while (without singing), then quiet them.
4. Then tell them, "OK, let's try singing and block clapping at the same time!" Lead the children in song and clapping.
5. If desired, you can ask the children a question related to the verse/the songs they are singing, using the Deep Down Detectives Discussion Sheet after each time (or every few times) you sing the song/say the verse.

NOTE: Younger children may need to sing the Bible verse/Big Question song/etc, then clap. But, as the children get older, they may be able to sing the song(s) AND clap at the same time.

Music, Movement & Memory Activity

Intake or Response Activity to learn the Big Question, Bible verse and Unit music

Lullabies, Bells and Lions

Materials

- CD of unit music
- Bell
- Deep Down Detectives Discussion Questions (optional)

What to Do

1. Tell the children: "We're going to pretend to go to sleep as children, but wake up like an animal. Everyone sit down and let's sing our lullaby before we go to bed. When you hear the morning bell ring, you can pretend to be the animal I say until you hear the bedtime bell ring and you have to sit back down."
2. Ring the bell and say, "It's time for bed, it's time for bed! Sit down where you are, you sleepy heads!" Have all the children sit down in place. Then say, "Before we go to sleep, we have to sing our bedtime lullaby. Let's sing our Bible verse song/Big Question song/Praise Song/Hymn." Have the children sing the song with you, then tell them, "Shhh. Lay down! It's time for bed!"
3. Have all the children lay down and be very still and quiet like they are sleeping for a few minutes. Then say, "Sleeping, sleeping, look at all the sleeping children. But when the morning bell rang, they all woke up, and were lions (or whatever animal you choose) all day!"
3. All the children will get up and pretend to be the animal. After a few moments, ring the bell and say, "It's time for bed, it's time for bed! Sit down where you are, you sleepy heads!"
4. If desired, you can ask the children a question related to the verse/the songs they are singing, using the Deep Down Detectives Discussion Questions after each time (or every few times) you sing the lullaby song.

Music, Movement & Memory Activity

Intake or Response Activity to learn the Big Question, Bible verse and Unit music

Musical Squares

Materials

- CD of unit music
- Carpet Squares, enough for all of the children (or chairs)
- Deep Down Detectives Discussion Questions (optional)

What to Do

1. Set out the squares/chairs in a circle. Ask the children to sit down on their square/chair.
2. Tell the children they will march around behind the squares/chairs as you play the Big Question Song/Bible verse song/Hymn/Praise Song/etc. When the music stops, they are to sit down on the nearest square/chair island.
3. Play the music, sing the song as the children make swimming motion with their arms to it. Stop the music and have the children sit down on the nearest square/chair.
4. If desired, you can ask the children a question related to the verse/the songs (or the lesson concepts) they are singing, using the Deep Down Detectives Discussion Questions, after each time (or every few times) they sit down.

Bible Story Review Game

Response Activity to review the story and key concepts

Take Me Through the Tunnel

Materials

- Bible Truth storyboard pictures and Storyboard
- Deep Down Discussion Questions
- Chairs or Table
- Sheet or blanket
- Box

Preparation

1. Construct a tunnel using the sheet draped over a table/chairs.
2. Put the flannelgraph figures in a box in the "tunnel."

Playing the Game

1. Have the children take turns crawling through the tunnel, retrieving one of the pictures.
2. When the child comes out of the tunnel, he shows the figure to the other children from them to name.
3. Have the children name the character; and, if desired, answer a question (see Deep Down Discussion Sheet) about what they did in the story.
4. Have the child stick the picture on the storyboard, gradually recreating the scene as the game progresses.

Bible Story Review Game

Response Activity to review the story and key concepts

Missing in Action

Materials

- Bible Truth storyboard pictures and Storyboard
- Deep Down Discussion Questions

Preparation

1. Put all the story pictures up on the storyboard, recreating the scene from the story. .

Playing the Game

1. Review the story briefly, pointing to the figures on the story board background as you go. Have the children help you, if desired.
2. Tell the children that someone from the story is about to go "Missing in Action" and they have to guess who it is. Have the children cover their eyes and take one figure off the board.
3. Have the children open their eyes and figure out who is missing.
4. Put the picture back on the board. Take another picture off the board, having a child choose who will go missing in action this time.
5. If desired, you can ask the children a question related to story each time/every few times a picture is put up, using the Deep Down Discussion Sheet.

Bible Story Review Game

Response Activity to review the story and key concepts

Treasure Hunt

Materials

- Bible Truth storyboard pictures
- Deep Down Discussion Questions
- 10 small lidded plastic containers or boxes (like from a jewelry store) or wooden, hinged boxes from a craft store
- Various decorating supplies, such as fake craft jewels, glitter, glitter glue, foil paper, gold spray paint glue

Preparation

Before playing the game, you will need to make your treasure boxes:

1. Collect 10 small lidded plastic containers or lidded boxes (like from a jewelry store), just large enough to put the Bible story pictures in. Alternatively, you can also purchase 10 hinged wooden boxes from a craft store. These make marvelous treasure boxes.
2. Decorate each container/box with the jewels, glitter, paper, gold paint, etc to give them a “treasure-y” look.

Right before Class:

1. Put a Bible story picture in each container and hide them around the room.
2. You may want to review the story and the pictures before class.

Playing the Game

1. Tell the children that you are going on a treasure hunt and need their help finding all the treasure hidden around the room.
2. Have the children take turns finding the treasure boxes and bringing them to you.
3. Remove each picture as the box is found and ask the children review questions about the character from the Bible story. If desired, you can simply put each picture on the floor, table, or storyboard as it is found, then ask questions about the Bible story when you have collected them all. (See the Deep Down Discussion Sheet for possible questions.)
4. Remember to store your boxes after the game, keeping them for the next time you play.
5. Game continues as time allows or until you have retrieved and reviewed all the pictures and the story.

Bible Story Review Game

Response Activity to review the story and key concepts

Look Who's Coming Down the Tracks

Materials

- Bible Truth storyboard pictures
- Deep Down Discussion Questions
- Two shoe boxes
- 6' or so of rope
- Optional: Engineer's hat

Preparation

1. Make a "train" with two cars made with the two shoe boxes strung together with rope.
2. Poke a hole through the front short side of the shoe box that will be the back "car."
3. Poke a hole through the front and back short sides of the shoe box that will be the front "car."
4. Thread the rope through these holes, tying knots near the inside and outside of each to keep the car securely in place.

Playing the Game

1. Put a picture in each "car" of the train (out of the sight of the children). Say, "Look who's coming down the track!"
2. Hand the end of the rope to a child and have them pull it around to where the other participating children are saying "Choo! Choo! Choo! Choo!" (you can have all the children say this, just the child pulling, you and the child, etc.)
3. After the child pulls it to where the children are say, "Train, stop!"
4. Pull out the pictures, show them to the children and ask, "Who's on our train?"
5. If desired, you can ask the children a question related to the picture/story, from the Deep Down Detectives Discussion Sheet.

Tip: For more fun, have a train engineer's hat for the child pulling the train to wear.

Bible Story Review Game

Response Activity to review the story and key concepts

Can You Remember?

Materials

- 2 sets of Bible Truth storyboard pictures (Simply photo copy a second black & white set from the originals)
- Deep Down Discussion Questions
- Index Cards

Preparation

1. Attach the storyboard pictures to index cards, making sure that the pictures are completely covered by the cards.
2. Scramble the order of pictures and set face down on the floor or table.

Playing the Game

1. Have the children take turns trying to make matches by choosing and turning over two pictures at a time.
2. If the pictures match, they are removed from the floor and one is placed on the storyboard. Have the children identify the pictures as they are added to the board. If they do not match, they are turned over face down again and someone else gets to try.
3. If desired, you may also want to ask the children a question about the picture/the story as a match is made, using the Deep Down Discussion Sheet for suggestions.
4. Continue until all the matches are made and all pictures are up on the storyboard, recreating the story picture.

Bible Story Review Game

Response Activity to review the story and key concepts

Clothespin Line Up and Drop

Materials

- Bible Truth storyboard pictures
- Deep Down Discussion Questions
- Rope
- Clothespins, the hinged type
- Shoe box
- Tape

Preparation

1. Attach a spring-type clothespin to some of the laminated storyboard pictures and put them in a shoe box with the lid taped on one side like a hinge and with a hole in the top.
2. Hang up a short rope (in an out-of-traffic-flow location) between two chairs.

Playing the Game

1. Open the shoe box and say, "It's time to say hello to our story friends!"
2. Pull the pictures out one at a time, saying "Hello, so-and-so, each time you pick up a picture and clip them to the rope.
3. When all are pinned up say, "It's time to say goodbye to so-and-so." Can you find so-and-so?" Then have the child point out the right figure on the clothesline, take it off the rope, reattaching the clothespin and handing it to the child. If desired, you may also want to ask the children a question about the picture/the story as the picture is identified, using the Deep Down Discussion Sheet for suggestions.
4. Have a container/bucket/shoe box and say, "Say, goodbye!" letting the child drop the clothespin in the bucket and put the picture through the slot in the shoe box.

Bible Story Review Game

Response Activity to review the story and key concepts

Deep Down Detectives Clue Hunt

Materials

- Bible Truth storyboard pictures
- Deep Down Discussion Questions
- Variety of interesting items that have one or more places to hide a storyboard picture
- Detective Hat
- 4 False Clues (included on the next page)
- CD Player and Deep Down Detectives Theme Song

Preparation

1. Collect a variety of interesting items, that some way to hide a picture, such as an old box with a lid, wallet, purse, clothing with pockets, a book, etc. If your items have MORE than one place to hide things, that is even better.
2. Cut out/Print out the false clue pictures included with the game.
3. Hide each story picture inside one of the items.
4. Set out the items for the children to see, telling them that each of them have an important clue in them. Most of them are from the story, but a few are not. Tell them that it is the job of the Deep Down Detectives to find the hidden clues and decide if they belong in the story or not.

Playing the Game

1. Have the children line up. Play the Deep Down Detectives Theme Song and lead the children in marching around the room and then back to their places to sit down as it ends. (This is merely an energy-release tactic). Have the children take turns choosing an item, finding the clue you have hidden within it. Have the child/the class decide if the clue belongs in the story or not. If it belongs in the story, have them tell how, or, you could ask the children a question about the picture, using the Deep Down Discussion Sheet for suggestions.
2. Continue until all the clues have been found.
3. If desired, you can have the child who will choose the next clue to lead the class in marching to the theme song before they choose their clue.

Bible Story Review Game

Response Activity to review the story and key concepts

Deep Down Detectives Clue Hunt, continued

False Clues (use as many as you want)

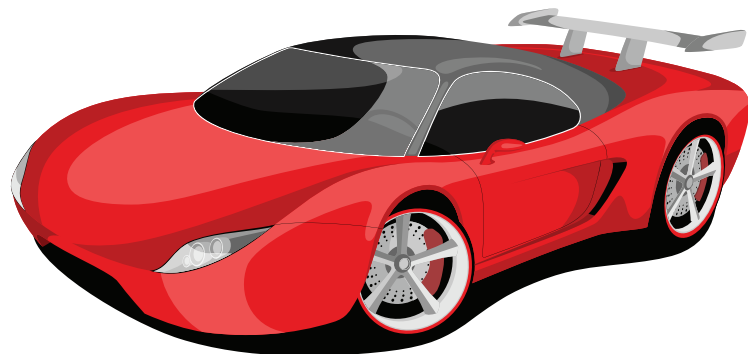

Bible Story Review Game

Response Activity to review the story and key concepts

Run to the Grocery Store

Materials

- Bible Truth storyboard pictures
- Deep Down Discussion Questions
- Grocery bag or kid's grocery cart
- Empty food cartons

Preparation

1. Put a clue inside each food container.
2. Set out the containers on a table or shelf at one end of the room.
3. Set up the story board at the other end, with the shopping cart or bag.

Playing the Game

1. Have the children assemble near the storyboard.
2. Have them take turns pushing the grocery cart/carrying the grocery bag to the other end of the room and choosing a food item. If desired, tell the children which food item you want them to pick out each time.
3. When the child returns with the food, have them open the container and pull out the picture. If desired, you may also want to ask the children a question about the picture/the story as the picture is identified, using the Deep Down Discussion Sheet for suggestions.
4. Ask the class what the picture is, then add it to the story board, gradually reproducing the story.

Bible Story Review Game

Response Activity to review the story and key concepts

Who's in the Basket?

Materials

- Bible Truth storyboard pictures
- Deep Down Discussion Questions
- Blanket
- Basket

Preparation

None.

Playing the Game

1. Hide one of the pictures in the basket and cover it up with the blanket.
2. Ask the children: "Who's in the basket? Would you like to look?" Have chose a child to take off the blanket and pull out the picture to show the rest of the children. Say: "Look! It's -----" The children or you or you and the children can answer with who it is. For more fun, have a little song like "Pop! Goes the Weasel" you hum each time before the child pulls the blanket off Or, just count "1, 2, 3, GO!" and pull the blanket off quickly. If desired, you may also want to ask the children a question about the picture/the story as the picture is identified, using the Deep Down Discussion Sheet for suggestions.
3. Repeat as frequently as desired.

Bible Story Review Game

Response Activity to review the story and key concepts

Going Fishing

Materials

- Bible Truth storyboard pictures
- Deep Down Discussion Questions
- One long wooden dowel, yardstick, etc. per fishing pole
- Yarn
- Paper clip per fishing pole
- Rope
- Two chairs
- Blanket
- Box/bucket/container
- Bucket

Preparation

1. Make fishing poles out of long wooden dowels, yardsticks, etc with a piece of yarn for fishing line and a paper clip for a hook.
2. Attach a picture to the end of each pole.
3. Tie a rope between two chairs and drape a piece of cloth or a blanket over the rope. Lay the poles against the blanket so that the tips and the fishing line drape over the other side and drop down into a bucket/box on the other side.
4. Place other bucket on the side the children and the ends of the fishing rods are. This will be the "holding tank" for the fish when they are caught.

Playing the Game

1. Ask the children, "Would you like to go fishing in my pond today?"
2. "Let's see what you'll catch." The child chooses one of the poles, pulls it up and see what's on the end.
3. Say "Looks like you've caught a big one! Pull it out!"
4. As the child pulls up the fishing rod and reveals what is on the end, ask the children, "Who did you catch?" If desired, you may also want to ask the children a question about the picture/the story as each "fish" is caught, using the Deep Down Discussion Sheet for suggestions.
5. Have the child put the "fish" in the holding tank.
6. If desired, when all the fish are caught, take them out of the holding tank and review the "catch of the day."

Bible Story Review Game

Response Activity to review the story and key concepts

Pony Express

Materials

- Bible Truth storyboard pictures
- Deep Down Discussion Questions
- Small manila envelopes, one per flannel graph figure
- Kid's small backpack or a tote bag with a strap
- Basket
- Cowboy hat
- Stick horse or a broom

Preparation

1. Tell the children that long ago cowboys used to pick up the mail, put it in their bags and ride it fast from town to town on their horses. This was called the Pony Express. Today, they will practice riding for the Pony Express and bring the mail back to the class.

Playing the Game

1. Show the children how to ride the stick horse down to the other end, pick up a piece of mail from the basket, put it in their bag, then ride it back to the class. Take the envelope out of the bag and open it, showing them the picture inside. Ask the children who/what the picture is and then put it on the storyboard. If desired, you may also want to ask the children a question about the picture/the story as the picture is identified, using the Deep Down Discussion Sheet for suggestions.
2. Have the children take turns riding the Pony Express, each time adding the new figure to the storyboard until the story is recreated on it.

Bible Story Review Game

Response Activity to review the story and key concepts

Who's Inside?

Materials

- Bible Truth storyboard pictures (and/or other objects that remind you of things from the story)
- Deep Down Discussion Questions
- 10 different containers with lids

Preparation

1. Put in various pictures/objects in each container and shut.
2. Line up all the containers or put them in a big bag, such as a trash bag.

Playing the Game

1. Have 10 different sized/colored lidded containers with shaded sides, all big enough to fit the laminated pictures or other objects from the story or concept. Have the children take turns choosing a container (from the bag) and opening it. Each time ask: "Who's inside?" Child/children/you/you and children can answer together. If desired, you may also want to ask the children a question about the picture/the story as each picture/object is identified using the Deep Down Discussion Sheet for suggestions.
2. Repeat.

Bible Story Review Game

Response Activity to review the story and key concepts

Fix Up the Mix Up

Materials

- Bible Truth storyboard pictures
- Deep Down Discussion Questions

Preparation

None.

Playing the Game

1. Take all the Storyboard pictures and mix them up in a pile in front of the children.
2. Tell them that the story pictures are all mixed up and you need help fixing them up again.
3. Let the children take turns picking a picture out of the pile and re-constructing the story on the storyboard. If desired, you may also want to ask the children a question about the picture/the story as each picture/object is identified using the Deep Down Discussion Sheet for suggestions.

DEEP DOWN DETECTIVES

Curriculum Resources



**Appendix C:
Crafts and Take Home Sheets**

Index of Crafts and Take Home Sheets

Unit 11, Bible Truth 1:

Coloring Sheet/Take Home Sheets	209
Big Question 11 Bible Story and Key Concepts to Take Home	215
Extra Crafts 1-3	223

Unit 11, Bible Truth 2:

Coloring Sheet/Take Home Sheets	231
Big Question 11 Bible Story and Key Concepts to Take Home	237
Extra Crafts 1-3	245

Unit 11, Bible Truth 3:

Coloring Sheet/Take Home Sheets	251
Big Question 11 Bible Story and Key Concepts to Take Home	257
Extra Crafts 1-3	265

CAN YOU GUESS BIBLE TRUTH!
How Can We Be Saved?
It Is God's Free Gift...

When We Tell God Our

and Turn Away from Them!

**HINT: What is the Bible word for disobeying God
and His good laws? It starts with an "s"
and it rhymes with "ends."**

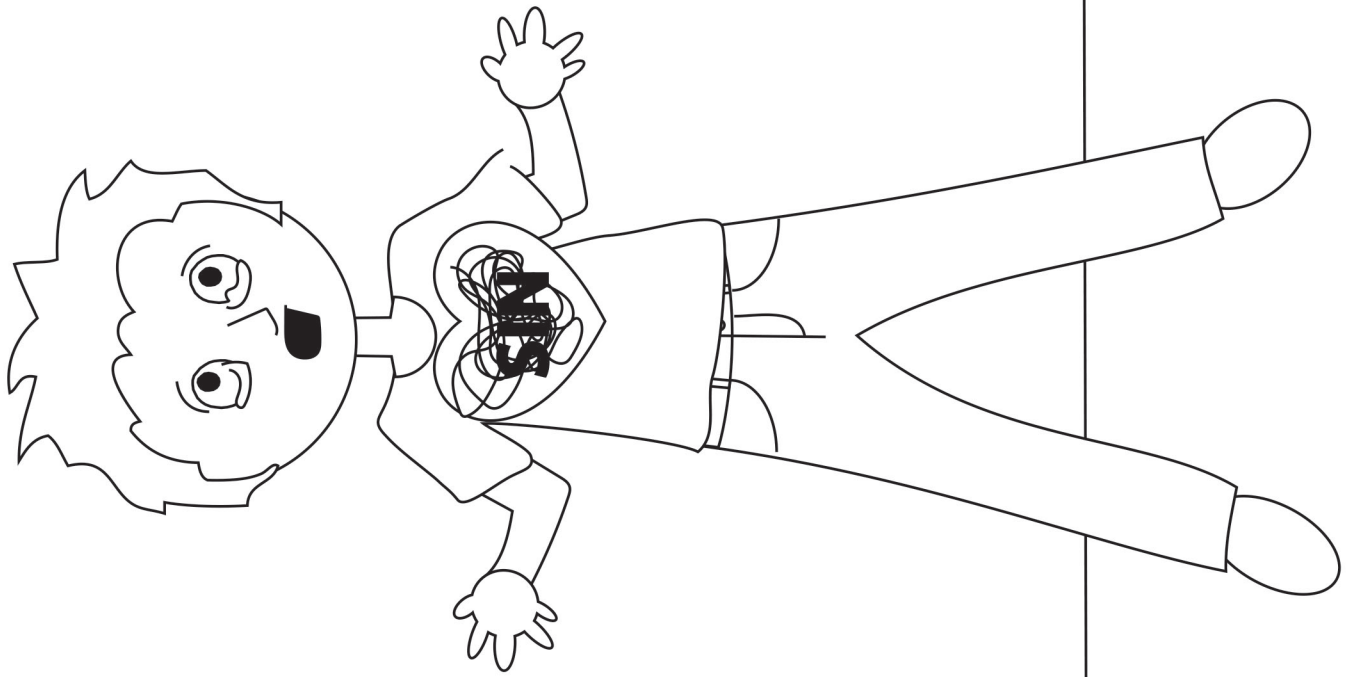

Deep Down Detective Devotion: Unit 11, Bible Truth 1, Lesson 1



Big Question 11: How Can We Be Saved?

Answer: It Is God's Free Gift... When We Tell God Our Sins and Turn Away from Them!

Bible Truth 1 Meaning

We are all sinners who disobey God. We hear God's laws from the Bible, and we know that we have broken them. We hear how we are supposed to love God and His good ways, and we know that we do not. We hear about God's punishment for sin, and we know that we deserve it. But God is so merciful! He has provided a way to save us from His punishment. How? God wants us to tell (confess) our sins to Him and ask for His forgiveness through His Son, Jesus, who died on the cross to take the punishment for the sins of God's people. And, God wants us to turn away from a life of disobeying Him and ask Him to help us to live for Him instead (that's what it means to repent of our sins.) If we do these things, God promises to forgive our sins and make us His very own people. We will get to know Him in our hearts by His Holy Spirit now. And one day, when we die, we will go to live perfectly happily with Him forever.

How do I know this is true? The Bible tells me so!

"If we say we have no sin, we deceive ourselves, and the truth is not in us. If we confess our sins, he is faithful and just to forgive us our sins and to cleanse us from all unrighteousness." --1 John 1:8-9, ESV

Some Questions for You

1. Who are sinners? *We all are.*
2. When we hear God's big rules, His laws, what do we know? *That we have broken them.*
3. When we hear we are supposed to love God and His good ways, what do we know? *That we do not love Him or His good ways as we should.*
4. When we hear about God's punishment for sin what do we know? *That we deserve it.*
5. Does God want us to have His punishment for sin? *No, He does not. He wants to save us.*
6. How can we be saved? *By telling Him our sins, turning away from wanting to disobey Him; and trusting in Jesus as our Savior.*
7. What does God promise to do when we trust Jesus as our Savior? *Forgive our sins, make us His very own people, and give us special closeness with Him now and forever.*

Let's Pray!

- A** God, we praise You for being faithful and just, and able to forgive our sins.
- C** God, we confess that we are all sinners who need You to save us. We can never be acceptable to You on our own. We need Jesus to save us!
- T** Thank You, God, for being willing to forgive all our sins, when we confess them, turn away from them, and trust in Jesus as our Savior.
- S** God, work in our hearts. Show us our sins and our need for Jesus to save us. Help us to confess our sins to You and turn away from them. Help us to trust in Jesus as our Savior. Be our Heavenly Father! Make us Your adopted children who love You and whom You will love forever. In Jesus' name we pray, Amen.

Let's Sing about What We're Learning!

Big Q & A 11 Song from Deep Down Detectives ESV Songs 11, track 12

(adapted version of "Here We Go Looby Loo")

How can we be saved?
 How can we be saved?
 How can we be saved?
 It is God's free gift!

Big Question 11 Action Rhyme Song from Deep Down Detectives ESV Songs 11, track 13

Refrain:

How can we be saved?
 How can we be saved?
 How can we be saved?
 It's God's free gift.
 How can we be saved?
 How can we be saved?
 How can we be saved?
 How can we be saved?
 It's God's free gift through Christ.

Verse 1

I disobey God, I need a Savior,
 You disobey God, You need a Savior,
 We all disobey God, We need a Savior.
 To save us from our sins. *Refrain*

Verse 2

Jesus, He paid the price, the perfect sacrifice,
 On the cross, gave His life,
 Bought us eternal life,
 Takes away all our sin,
 Makes our hearts clean within,
 When we repent and believe in Him. *Refrain*

**“If we say we have no sin, we deceive ourselves, and the truth is not in us.
If we confess our sins, he is faithful and just to forgive us our sins
and to cleanse us from all unrighteousness -- 1 John 1:8-9, ESV**

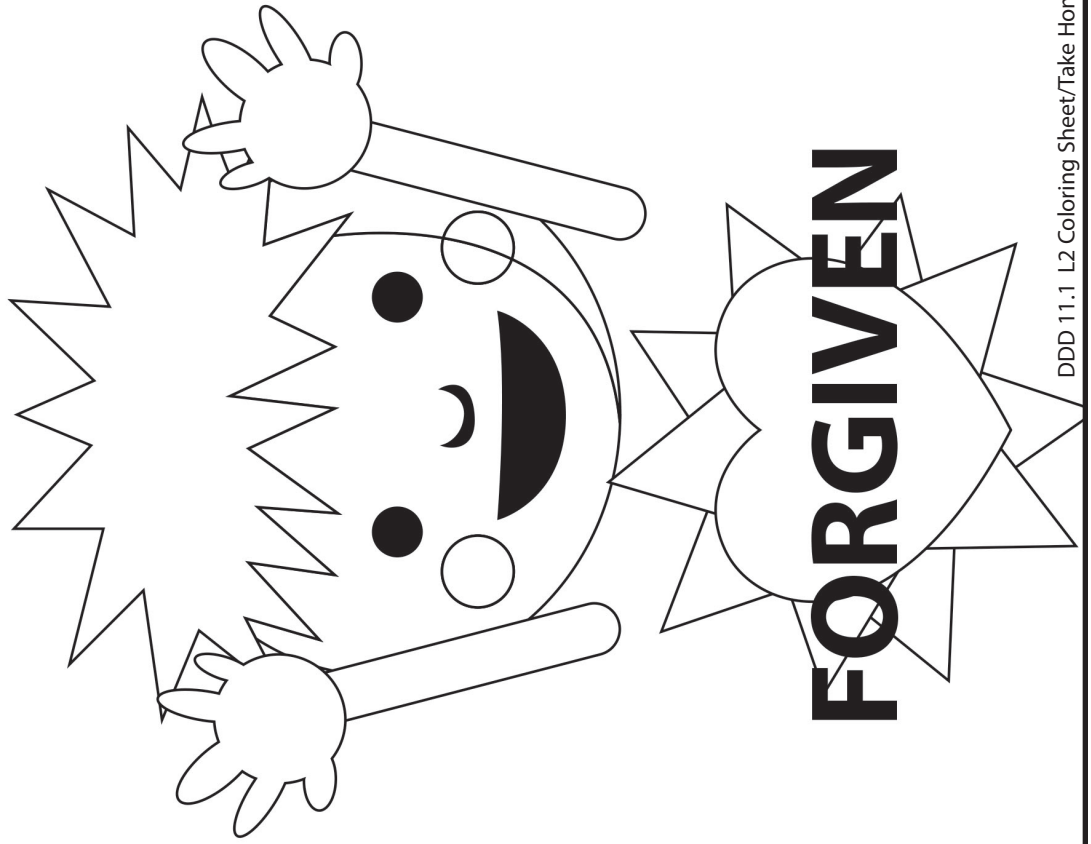
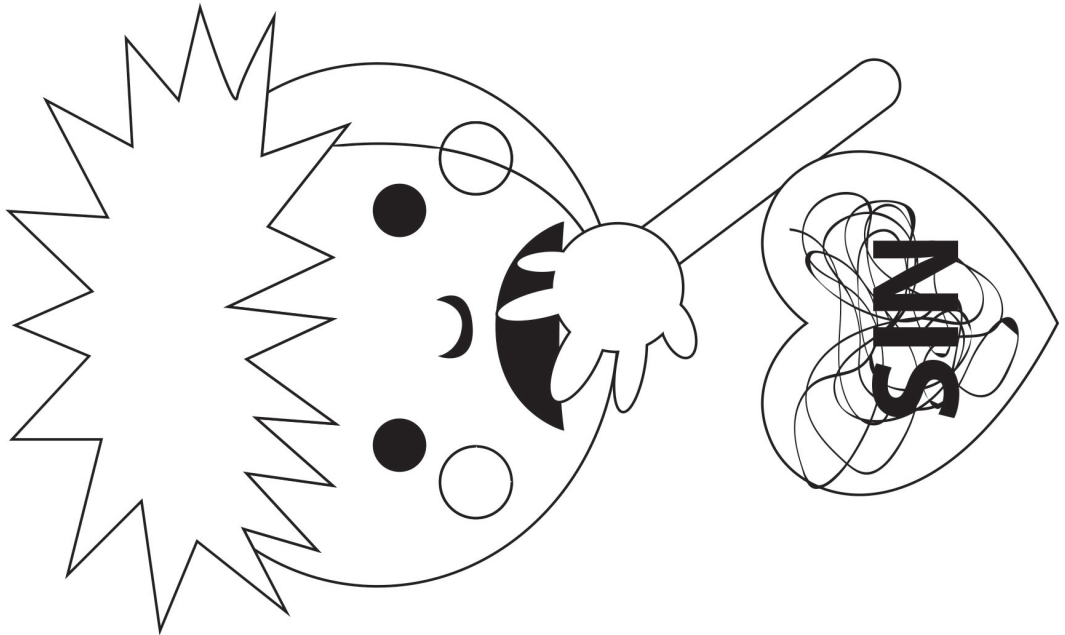

Deep Down Detective Devotion: Unit 11, Bible Truth 1, Lesson 2



Big Question 11: How Can We Be Saved?

Answer: God's Laws Are Perfect... When We Tell God Our Sins and Turn Away from Them!

How do I know this is true? The Bible tells me so!

"If we say we have no sin, we deceive ourselves, and the truth is not in us. If we confess our sins, he is faithful and just to forgive us our sins and to cleanse us from all unrighteousness." --1 John 1:8-9, ESV

Learn a Little: "If we confess our sins, he is faithful to forgive our sins."

Meaning

This verse reminds us that we are all sinners. We deceive ourselves if we think we are not. But, the good news is, that if we admit we are sinners and confess our sins to God, He is faithful and just and will forgive us our sins and save us through Jesus.

Some Questions for You

1. If we say we are without sin, who do we deceive (who are we fooling)? *Ourselves.*
2. Who is faithful to forgive our sins, if we confess them to Him? *God is.*
3. What does God purify us from when we confess our sins to Him? *All unrighteousness. That means He treats us as if we have never disobeyed Him.*
4. What do we need to do for God to forgive our sins? *We need to confess our sins to God, telling Him that we know that we have disobeyed Him and deserve His punishment. We need to turn away from our sins and trust in Jesus as our Savior. God promises to forgive the sins of all who do!*

Let's Pray!

- A** God, we praise You for being faithful and just, and able to forgive our sins.
- C** God, we confess that we are all sinners who need You to save us. We can never be acceptable to You on our own. We need Jesus to save us!
- T** Thank You, God, for being willing to forgive all our sins, when we confess them, turn away from them, and trust in Jesus as our Savior.
- S** God, work in our hearts. Show us our sins and our need for Jesus to save us. Help us to confess our sins to You and turn away from them. Help us to trust in Jesus as our Savior. Be our Heavenly Father! Make us Your adopted children who love You and whom You will love forever. In Jesus' name we pray, Amen.

Let's Sing Our Bible Verse!

If We Say We Have No Sin 1 John 1:8-9

from Deep Down Detectives ESV Songs 11, tracks 17

If we say we have no sin,
If we say we have no sin,
If we say we have no sin,
We deceive ourselves,
And the truth is not in us.

But...If we confess our sins...
He is faithful and just to forgive us our sins,
Faithful and just to forgive us our sins,
Faithful and just to forgive us our sins,
And to cleanse us from,
All unrighteousness.

First John One, verses eight and nine.

Go to the Deep Down Detectives Parent Resources for Unit 11 to get the Bible story and many more resources and songs for this unit at praisefactory.org

DDD BQ11 BT 1 L2 Coloring Sheet/Take Home pg2

Which four of these clues belong in our story? Which two do not? Put an X in the boxes of the four that belong.

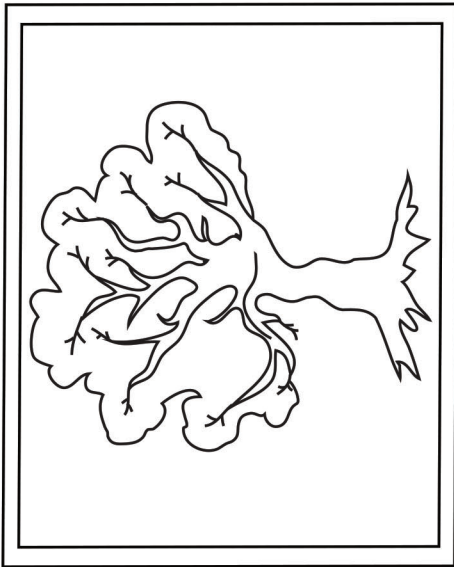

A Tree

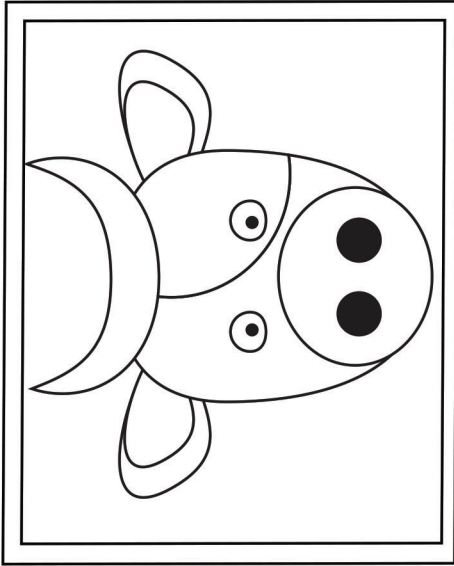

A Cow

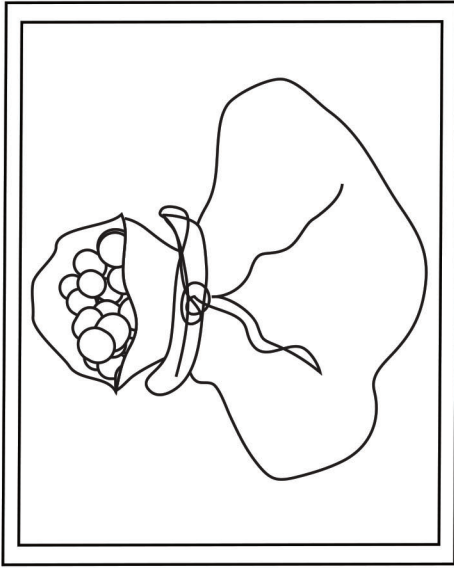

A Bag of Money

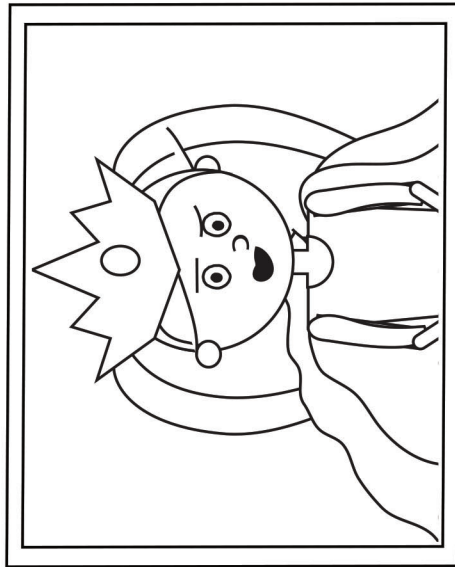

A King

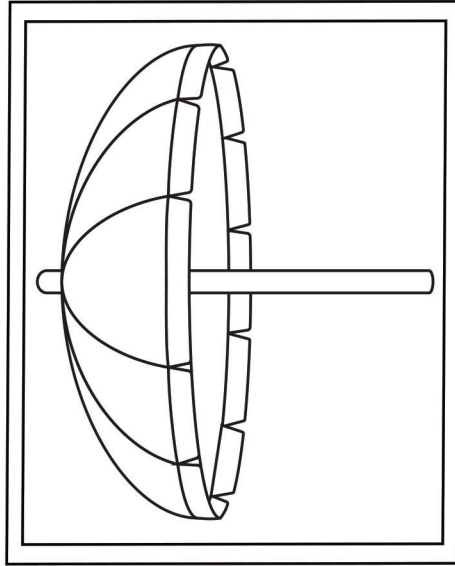

An Umbrella

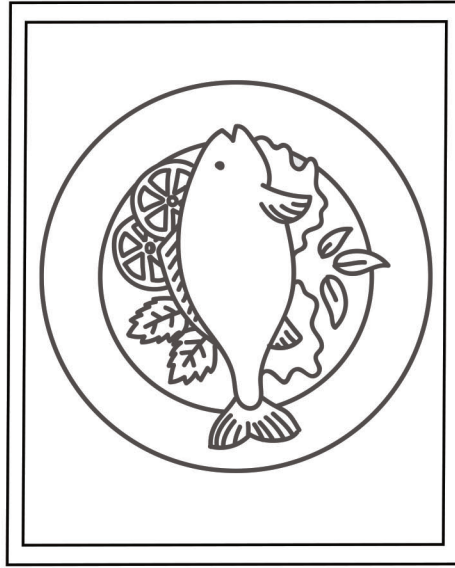

Yummy Food

Answer: The tree, the bag of money, the king and the yummy food belong. The cow and the umbrella do not.

Deep Down Detective Devotion: Unit 11, Bible Truth 1, Lesson 3



Big Question 11: How Can We Be Saved?

Answer: It Is God's Free Gift... When We Tell God Our Sins and Turn Away from Them!

Bible Truth 1 Meaning

We are all sinners who disobey God. We hear God's laws from the Bible, and we know that we have broken them. We hear how we are supposed to love God and His good ways, and we know that we do not. We hear about God's punishment for sin, and we know that we deserve it. But God is so merciful! He has provided a way to save us from His punishment. How? God wants us to tell (confess) our sins to Him and ask for His forgiveness through His Son, Jesus, who died on the cross to take the punishment for the sins of God's people. And, God wants us to turn away from a life of disobeying Him and ask Him to help us to live for Him instead (that's what it means to repent of our sins.) If we do these things, God promises to forgive our sins and make us His very own people. We will get to know Him in our hearts by His Holy Spirit now. And one day, when we die, we will go to live perfectly happily with Him forever.

How do I know this is true? The Bible tells me so!

"If we say we have no sin, we deceive ourselves, and the truth is not in us. If we confess our sins, he is faithful and just to forgive us our sins and to cleanse us from all unrighteousness." --1 John 1:8-9, ESV

Some Questions for You

1. What did Zacchaeus have? *Just about everything that money could buy.*
2. What did Zacchaeus want that money couldn't buy? *He wanted God's forgiveness.*
3. What kinds of bad things did Zacchaeus do to get all his money? *Good food, a nice house, beautiful clothes, and just about whatever else he wanted.*
4. What special place was Zacchaeus not allowed to go to because of the bad things he did? *The place to worship God.*
5. Why did Zacchaeus climb the tree? *He was too short to see Jesus and no one would make a place for him along the road.*
6. What did Jesus tell Zacchaeus to do? *To come down from the tree and take Him to his house to be his guest.*
7. What did Jesus offer Zacchaeus? *Forgiveness from his sins.*
8. What did Zacchaeus do that showed that he really had turned away from his sins and trusted in Jesus as his Savior? *He promised to pay back all the people whose money he had wrongly taken.*
9. Who worked in Zacchaeus' heart so that he would be changed? *The Holy Spirit.*
10. How can we have God's forgiveness for our sins? *By turning away from our sins and trusting in Jesus as our Savior.*

Let's Pray!

- A** God, we praise You for being faithful and just, and able to forgive our sins.
- C** God, we confess that we are all sinners who need You to save us. We can never be acceptable to You on our own. We need Jesus to save us!
- T** Thank You, God, for being willing to forgive all our sins, when we confess them, turn away from them, and trust in Jesus as our Savior.
- S** God, work in our hearts. Show us our sins and our need for Jesus to save us. Help us to confess our sins to You and turn away from them. Help us to trust in Jesus as our Savior. Be our Heavenly Father! Make us Your adopted children who love You and whom You will love forever. In Jesus' name we pray, Amen.

Let's Praise God Right Now!

Big Question 11 Hymn: Grace that Is Greater than All Our Sin *from Deep Down Detectives ESV Songs 11, track 15*

Verse 1

Grace, grace, God's grace,
Grace that will pardon and cleanse within;
Grace, grace, God's grace,
Grace that is greater than all our sin.

Words: Julie H. Johnston Music: Daniel B. Towner

Go to the Deep Down Detectives Parent Resources for Unit 11 to get the Bible story and many more resources and songs for this unit at praisefactory.org

Big Question 11 Praise Song: Blessed Be the Name *from Deep Down Detectives ESV Songs 11, track 16*

All praise to Him who reigns above In majesty supreme. Who gave His Son for man to die, That He might man redeem!	Blessed be the name, Blessed be the name, Blessed be the name of the Lord; Blessed be the name, Blessed be the name, Blessed be the name of the Lord.
--	--

Deep Down Devotions: Unit 11, Bible Truth 1 Story Concepts**P.1****The Case of the Changed Climber***Luke 19:1-9*

Dear Parents,

Big Question #11 is: "How Can We Be Saved?" Your child is learning that "It Is God's Free Gift... When We Tell God Our Sins and Turn Away from Them."

Here's a copy of the Bible story they are learning along with the "Listening Assignment" for each lesson. These assignments provide a different teaching emphasis for each lesson, helping the children dig deeper into each Bible truth. They match up with your child's take home for each lesson. We hope that these resources help your family to dig down deeper into the truths of God's Word!" Happy digging!

•many more resources for this Big Question can be found online at www.praisefactory.org•

Listening Assignments

"Hey, Kids! Detective Dan, here. Listen carefully to the story and help me answer these questions:

Detective Dan's Lesson #1 Listening Assignment:

I need to find out:

- 1. Who was the climber and why did he climb?**
- 2. How did he change?**

Detective Dan's Lesson #2 Listening Assignment:**Our Bible Verse is 1 John 1:8-9, ESV**

"If we say we have no sin, we deceive ourselves, and the truth is not in us. If we confess our sins, he is faithful and just to forgive us our sins and to cleanse us from all unrighteousness."

I need to find out:

- 1. Who wanted to confess his sins and be forgiven by God?**
- 2. Who didn't think he should be forgiven? Who did think he should be forgiven?**

Detective Dan's Lesson #3 Listening Assignment:

I found six clues, but only 4 of them are in the story.

Our six clues were: a tree, a cow, a bag of money, a king, an umbrella, and yummy food.

Hold each of them up for the children to see as you identify them.

I need to figure out:

- 1. Which four belong in the story and which two don't?**
- 2. Who confessed their sins to God and was forgiven? Who gave back the money he had stolen?**

Read the assignment questions, THEN SAY,

"Ok, Deep Down Detectives! Put on your best listening ears and see if you can hear the answers to Detective Dan's questions. When I finish telling the story, we will see if we can answer all the questions."

Read the Bible Truth story, answer questions, present the gospel and lead in prayer.

Answers to questions; the gospel; and, ACTS prayer are included with the story text.

The Case of the Changed Climber *Luke 19:1-9**Story with lines separating paragraphs (text in bold, optional interaction cues in italics)*

Zacchaeus was a rich, rich, rich man! He could have lots of fine clothes. He could have a big, big house. He could eat all the yummiest foods. He could buy all the nice things he liked. Yes. Zacchaeus could have almost anything he wanted because he was so rich.

But even though Zacchaeus could have almost ANYTHING he wanted, and almost ANYTHING money could buy, there was something that Zacchaeus did NOT have. It was something money could NOT buy.

What do you think Zacchaeus wanted that money could not buy?

Zacchaeus wanted God to forgive his sins.

Now, we know that no one deserves God's forgiveness of their sins. We have all disobeyed God. We all deserve His punishment. But to many, Zacchaeus ESPECIALLY didn't deserve to have his sins forgiven.

You see, Zacchaeus had chosen to work for Caesar, the big king in Rome. Caesar's soldiers had taken over Israel, the country where Zacchaeus and the other people lived. And one of the big things Caesar wanted from the people in Israel was MONEY. TAX MONEY.

The people of Israel hated to give the Roman king tax money, and most of them refused to help him collect it. But not Zacchaeus. Zacchaeus loved money and when the king offered to give him lots of money to collect taxes, Zacchaeus agreed.

"Zacchaeus, collect my tax money, and any extra you get, you can keep for yourself," the big, Roman king promised.

So, that's what Zacchaeus did. He became the head tax collector in the important city of Jericho. Zacchaeus and his men worked to get lots of money for Caesar and for themselves. Zacchaeus set up a booth along the road outside of Jericho. He stopped everyone along the road and made them pay taxes on their things. "Stop! No one passes by without paying the king's tax," demanded Zacchaeus and his men. They did the same thing to the people of Jericho. Zacchaeus and his men knocked on every door. "Bang, bang, bang! Pay your tax money right now," they ordered everyone.

Rich people, poor people. Healthy people, sick people. Everyone was ordered to pay, no matter how hard it was for them. No one wanted to pay. Many couldn't pay. But that didn't stop Zacchaeus. He and his men took soldiers with them to do whatever was needed to make people pay. So, pay they did, the amount Caesar wanted for his taxes, and a lot more that Zacchaeus and his men kept for themselves. Zacchaeus didn't mind if the people were scared. He didn't mind if he took too much money or made their lives sad. He didn't care what happened to anyone else. He only wanted more money for himself.

So, that's how Zacchaeus got to be so rich, rich, rich. And that's why people of Jericho and many others, thought Zacchaeus ESPECIALLY didn't deserve God's forgiveness.

"How could God forgive someone like Zacchaeus", they exclaimed. "He such a mean old greedy bully. Surely there is no forgiveness for someone like that!"

What do you think? Were the people right? Could Zacchaeus ever find God's forgiveness?

Story with lines separating paragraphs (text in bold, optional interaction cues in italics)

You might think all that money made Zacchaeus happy, and perhaps it did for a while. You see, fine clothes, a big, big house, yummy food, nice things are wonderful to have; but in the end, all those good things are never enough.

Why do you think all those good things would never be enough to make Zacchaeus happy?

Why? Because God made us to know, love, and obey Him. He, alone, can make us truly happy.

And that's why deep down in his heart, Zacchaeus was very UN-happy, even with all that money and those nice things. They would never be enough to satisfy him.

What was worse, Zacchaeus knew God's laws, and he knew that he had broken them. He had done many terrible things to the people in his town and the people who passed along the road. He had hurt those people and now they hated him.

Zacchaeus knew that he had chosen to turn away from God and His good ways. He had rebelled against God and deserved His punishment. It seemed like there was no way for Zacchaeus to come back to God now. Why, a man who had done such bad things wasn't even allowed to go in the worship house to worship God! How could a man this bad ever find forgiveness from God? Surely, there was no way!

Do you think there was no way for a bad man like Zacchaeus to come to God?

But there WAS a way to be forgiven. God had made a way through His Son, Jesus, as Zacchaeus found out one day.

Jesus and a crowd of people were passing through Jericho on the way to the big city of Jerusalem.

"Jesus is coming! Jesus is coming!" the exciting news spread throughout the town. Many gathered along the side of the road to see Jesus, squeezing together until there was no more room. Everyone wanted to hear Jesus teach about God and watch Him do amazing things by God's great power.

Zacchaeus tried to join the crowd to see Jesus, too, but no one would make room for him. Zacchaeus stood behind the crowd and tried to look over their heads, but he was such a short, little man that he couldn't see anything. Oh, if someone would just let him through to the front so he could see Jesus, too! But why would people help HIM after all the terrible things he had done?

"I must see Jesus! I must see Jesus!" Zacchaeus thought. He would not give up. Up! Why that was it. Zacchaeus had an idea.

What do you think Zacchaeus was going to do?

Zacchaeus would climb up a tree, then he could see Jesus without anyone getting in his way.

So, that's just what Zacchaeus did! He ran down the road, beyond the crowd, and climbed up a big, sycamore tree. Zacchaeus sat on his tree branch and watched as Jesus and the crowd with him came closer and closer and closer. What would happen? Would Jesus see Zacchaeus?

Do you think? Would Jesus see Zacchaeus hiding up in that tree?

Story with lines separating paragraphs (text in bold, optional interaction cues in italics)

It would have been so easy for Jesus to miss the short, little man hiding up among the leaves. But Jesus did NOT miss Zacchaeus. Jesus was LOOKING for him. Jesus knew all the terrible things Zacchaeus had done. He knew the sin in Zacchaeus' heart that made him so unhappy and separated him from God. And, Jesus knew that He could bring Zacchaeus the forgiveness from God he longed for.

So, instead of passing by Zacchaeus, Jesus led the crowd of people right up to that tree and stopped. He looked up through the leaves and straight at Zacchaeus.

What would Jesus say to Zacchaeus? What would Jesus DO to Zacchaeus? Zacchaeus was such a bad man and Jesus was so good! Would Jesus say angry things to Zacchaeus for all the bad things he had done? Would Jesus tell him there was no hope for a bad man like him?

What do you think Jesus would say to Zacchaeus?

Jesus had GOOD news for Zacchaeus. He had come to bring people like him to God! People who knew they had broken God's laws. Jesus had come to bring them God's forgiveness and to save them from God's punishment, no matter how bad they had been.

So, Jesus looked up at Zacchaeus, and said, "Zacchaeus, hurry and come down, for I must stay at your house today!"

Zacchaeus was shocked and so happy. Good teachers like Jesus never asked to stay at the house of bad men like him, no matter how rich they were. Zacchaeus knew what this meant. Jesus wasn't just asking to stay at his big house to enjoy his nice things and yummy food. Jesus was asking to stay at his house to welcome him back to God.

Oh, what wonderful news! More than all the fine clothes, the big house, the yummy food, and the nice things in the world, Zacchaeus wanted to be welcomed back by God. Oh, how he wanted God to forgive his sins!

Right then and there, God's Holy Spirit did a wonderful thing in Zacchaeus' heart. He helped Zacchaeus turn away from disobeying God and trust in Jesus as his Savior. Zacchaeus was forgiven by God for all the terrible things he had done. God had saved Zacchaeus through Jesus!

The town's people were shocked at Jesus' words and very unhappy!

Why do you think they weren't happy?

""How can Jesus stay with such a bad man who's done such terrible things and broken God's laws? Zacchaeus has lied and cheated us. He has shouted at us and hurt us. Zacchaeus has used soldiers to scare us. He's not even allowed in the worship place, he's so bad! A good teacher like Jesus shouldn't have anything to do with Zacchaeus, and He CERTAINLY shouldn't stay at his house!" they grumbled.

Jesus and Zacchaeus knew the people were right. Zacchaeus had been a very bad man. He had done terrible things and broken God's laws. He didn't deserve for Jesus to stay with him.

Story with lines separating paragraphs (text in bold, optional interaction cues in italics)

But Jesus and Zacchaeus knew the people were wrong about something, too. God had worked in Zacchaeus' heart. God had helped Zacchaeus turn away from his old, bad ways, and trust in Jesus as his Savior. God had forgiven Zacchaeus. Zacchaeus was a changed man!

Zacchaeus came down from that tree and showed just how changed he was. In front of everyone, he said, "Jesus, I'm going to give half of my money and nice things to poor people. And to the people I cheated, I'll give back everything I took and give them a whole lot more!" he promised.

"How amazing!" thought the town's people. "This doesn't sound like the same bad man who lied, cheated, and hurt us. This sounds like a NEW man, who loves God and wants to obey Him," they exclaimed.

And that's exactly what happened. God had changed Zacchaeus that day. God had helped him repent of his sins and trust in Jesus as his Savior.

Then, Jesus said to Zacchaeus and all the people, "God sent Me to seek and save people lost in their sins. And this is just what's happened today. God has forgiven Zacchaeus and made him one of His people!" Jesus! What a Savior for sinners!

Cracking the Case: (story wrap-up for Listening Assignments)

It's time to see how we did with our Listening Assignment.

Detective Dan's Lesson 1 Listening Assignment:**1. Who was the climber and why did he climb?**

Zacchaeus was the climber. He climbed up a tree, so he could see Jesus.

2. How did he change? Zacchaeus turned away from his sins. He stopped being a mean, greedy cheat. He put his trust in Jesus as his Savior and God forgave his sins and made him one of his people.

What about You and Me?

Like Zacchaeus, we All have disobeyed God and deserve his punishment. How sad! But like Zacchaeus, we, too, can confess our sins to God and turn away from them. We can trust in Jesus as our Savior. And if we do, God will forgive our sins and make us one of His people, just like He did for Zacchaeus.

Detective Dan's Lesson 2 Listening Assignment:**Our Bible Verse is 1 John 1:8-9, ESV**

"If we say we have no sin, we deceive ourselves, and the truth is not in us. If we confess our sins, he is faithful and just to forgive us our sins and to cleanse us from all unrighteousness."

1. Who wanted to confess his sins and be forgiven by God? Zacchaeus did.

2. Who didn't think he should be forgiven? Who did think he should be forgiven? The people in Zacchaeus' town of Jericho didn't think Zacchaeus should be forgiven by God. He was too bad of a man. But Jesus welcomed Zacchaeus to be forgiven by God.

What about you and me?

No one is too bad to be forgiven their sins by God. All who turn away from their sins and trust in Jesus as their Savior will be forgiven their sins and saved! God can do this for you and me, too. Ask Him! He loves to answer this prayer.

Detective Dan's Lesson 3 Listening Assignment:

Our six clues were: a tree, a cow, a bag of money, a king, an umbrella, and yummy food.

1. Which four belong in our story?

The tree, the bag of money, the king and the yummy food belong. The cow and the umbrella do not.

2. Who confessed their sins to God and was forgiven?**Who gave back the money he had stolen?**

Zacchaeus did.

For You and Me:

Like Zacchaeus we are sinners who need to confess our sins to God. Like Zacchaeus, if we do and turn to trust in Jesus as our Savior, God will forgive our sins we can become one of His dearly loved people forever.

The Gospel (story wrap-up if NOT using Listening Assignments)**Our Bible Truth is:****How Can We Be Saved?****It Is God's Free Gift...****"When We Tell God Our Sins and Turn Away from Them!**

Not just people like Zacchaeus who do lots of bad things need to be saved. We all do! For we all have chosen to disobey God and we all deserve God's punishment for our sins.

What good news we have, though! God promises to save all who turn away from disobeying Him and trust in Jesus as their Savior, even you and me!

Let's ask God to work in our hearts, just like He worked in Zacchaeus' heart. Let's ask Him to help us to turn away from disobeying Him and trust in Jesus as our Savior, so that we, too, might be saved.

Close in prayer.

Closing ACTS Prayer

- A** God, we praise You for being faithful and just, and able to forgive our sins.
- C** God, we confess that we are all sinners who need You to save us. We can never be acceptable to You on our own. We need Jesus to save us!
- T** Thank You, God, for being willing to forgive all our sins, when we confess them, turn away from them, and trust in Jesus as our Savior.
- S** God, work in our hearts. Show us our sins and our need for Jesus to save us. Help us to confess our sins to You and turn away from them. Help us to trust in Jesus as our Savior. Be our Heavenly Father! Make us Your adopted children who love You and whom You will love forever. In Jesus' name we pray, Amen.

Big Question 11, Bible Truth 1 Overview: Key Concepts

p.7

Unit 11: The God Who Saves

Unit Big Question (and Answer): How Can We Be Saved? It Is God's Free Gift!

Unit Bible Verse: "For the wages of sin is death, but the free gift of God is eternal life in Christ Jesus our Lord."
--- Romans 6:23, ESV

Bible Truth 1 Concept: It's God's Free Gift... When We Tell God Our Sins and Turn Away from Them!

We are all sinners who disobey God. We hear God's laws from the Bible and we know that we have broken them. We hear how we are supposed to love God and His good ways, and we know that we do not. We hear about God's punishment for sin, and we know that we deserve it.

But God is so merciful! He has provided a way to save us from His punishment. How? God wants us to tell (confess) our sins to Him and ask for His forgiveness through His Son, Jesus, who died on the cross to take the punishment for the sins of God's people. And, God wants us to turn away from a life of disobeying Him and ask Him to help us to live for Him instead (that's what it means to repent of our sins.)

If we do these things, God promises to forgive our sins and make us His very own people. We will get to know Him in our hearts by His Holy Spirit now. And one day, when we die, we will go to live perfectly happily with Him forever.

Bible Truth 1 Bible Verse: 1 John 1:8-9

"If we say we have no sin, we deceive ourselves, and the truth is not in us. If we confess our sins, he is faithful and just to forgive us our sins and to cleanse us from all unrighteousness."

Learn a Little: "If we confess our sins, he is faithful to forgive our sins."

Meaning

This verse reminds us that we are all sinners. We deceive ourselves if we think we are not. But, the good news is, that if we admit we are sinners and confess our sins to God, He is faithful and just and will forgive us our sins and save us through Jesus.

Bible Truth 1 ACTS Prayer

- A** God, we praise You for being faithful and just, and able to forgive our sins.
- C** God, we confess that we are all sinners who need You to save us. We can never be acceptable to You on our own. We need Jesus to save us!
- T** Thank You, God, for being willing to forgive all our sins, when we confess them, turn away from them, and trust in Jesus as our Savior.
- S** God, work in our hearts. Show us our sins and our need for Jesus to save us. Help us to confess our sins to You and turn away from them. Help us to trust in Jesus as our Savior. Be our Heavenly Father! Make us Your adopted children who love You and whom You will love forever.

In Jesus' name we pray, Amen.

Bible Truth 1 Story**The Case of the Changed Climber**

Luke 19:1-9

Big Question 11, Bible Truth 1 Overview: Key Concepts

p.8

Songs Used in Bible Truth 1

Big Q & A 11 Song

Big Question 11 Song: How Can I Be Saved?

Big Question 11 Bible Verse Song: The Free Gift of God Is Eternal Life Romans 6:23, ESV

Big Question 11 Hymn: Grace Greater than All Our Sin, refrain

Big Question 11 Praise Song: Blessed Be the Name

Bible Truth 1 Bible Verse Song: If We Say We Have No Sin 1 John 1:8-9, ESV

Extra Bible Truth 1 Bible Verse Song: If We Say 1 John 1:8-9, ESV

listen to or download songs for free at <https://praisefactory.org>: Deep Down Detectives Music page

Go and Tell Bible Truth Concept Craft

“Sorry and No” Hands

Craft Description

The children will make a pair of hands that pray “Sorry, God” and say “no” to sin.

Materials

White Cardstock
Markers or crayons
Sequins, sticky backed jewels (or earrings), glitter glue (optional)
Scissors (teacher use)
Glue sticks

Preparations

1. Print out one copy of the hands per child. Make sure to make the copies double-sided so that the front and back of the hands are on opposite sides of the cardstock. Print out on regular paper or cardstock as many copies as needed of the sheets with the signs “Sorry, God” and “No, Sin!” on them, one of each per craft.
2. Cut out signs.
3. Prepare the hands for the children by folding the paper in half, in between the two hands. Make sure that the plainer hands are on the outside and the hands with the Bible verse and the palm creases are in the inside. Cut around the hand shapes.
4. Set out markers/crayons, glue (regular glue), and decorating supplies.

Introducing the Craft:

“Our Big Question is: “How Can We Be Saved? It is God’s Free Gift...When We Tell God Our Sins and Turn Away from Them!” That’s something very good to know. But many people don’t know that. So do you know what God wants us to do? He wants us to go and tell others this very important news. So today we are going to make something we can show and tell them, too. Here’s what it looks like... (Hold up example of craft)

Directions

1. Show children your finished craft, reading the words to them.
2. Have the children color in the hands and around the words on the signs.
3. Help the children glue their signs in place, putting the “Sorry, God” sign near the top of the outer (prayer) hands and the “No, Sin!” near the top of the inner open hands (which open out as if holding something away from you in a “No” gesture).
4. Children can use the glitter glue, sequins, etc. to add rings and other decorations to the hands.
5. Make sure to write each child’s name on their craft.
6. If you have time, you can practice opening and closing the hands (prayer hands, then “No” hands) and saying the words on the card.

Discussion

This is an especially good time to re-read the key concepts and discuss them. See the Deep Down Discussion Sheet for possible questions to talk about.

Craft Wrap-Up:

“At the end of our time together today, you get to take home your Go and Tell crafts. And what are you going to do with them? Show and tell someone the important news you’ve learned today: “How Can We Be Saved? It is God’s Free Gift...When We Tell God Our Sins and Turn Away from Them!”



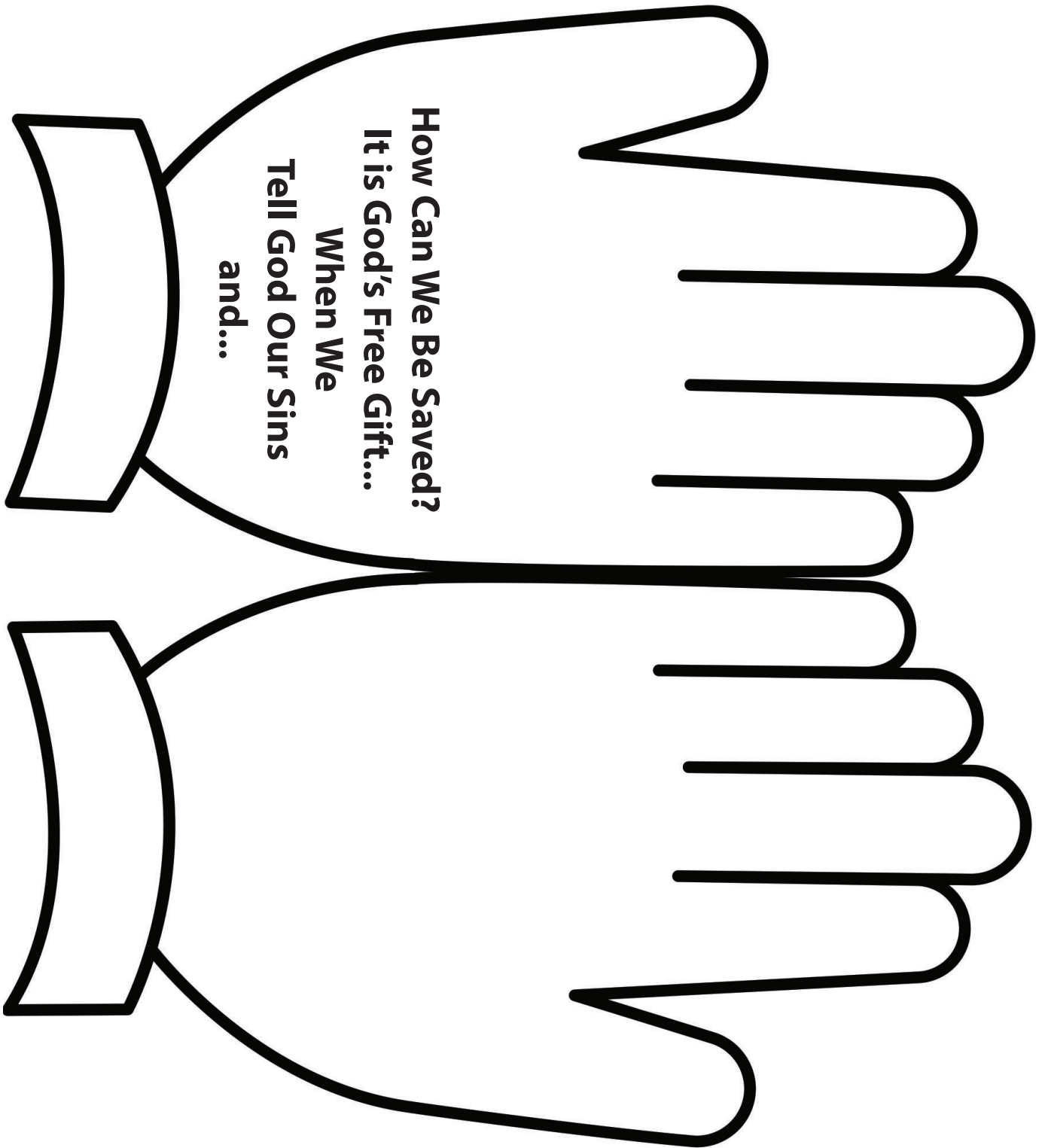

“Sorry,
God!”

“Sorry,
God!”

“Sorry,
God!”

“Sorry,
God!”

“Sorry,
God!”

“Sorry,
God!”

“Sorry,
God!”

“Sorry,
God!”

“Sorry,
God!”

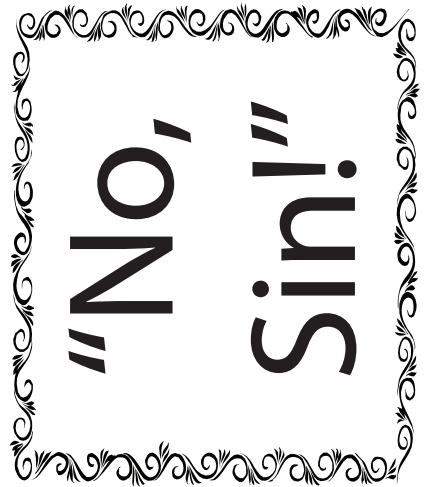
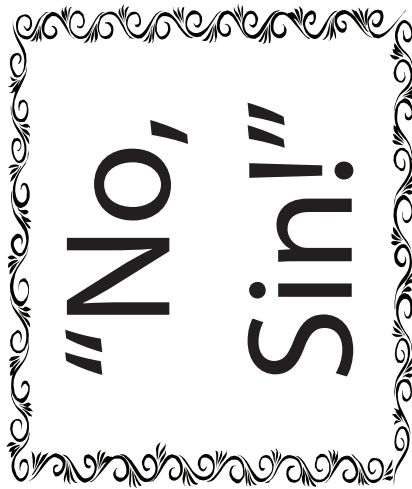
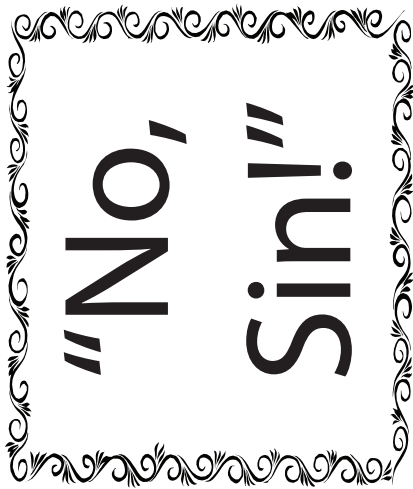
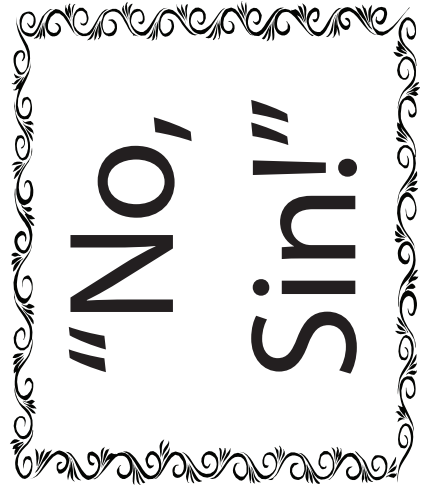
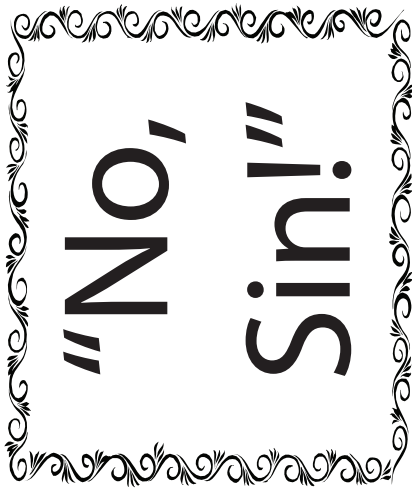
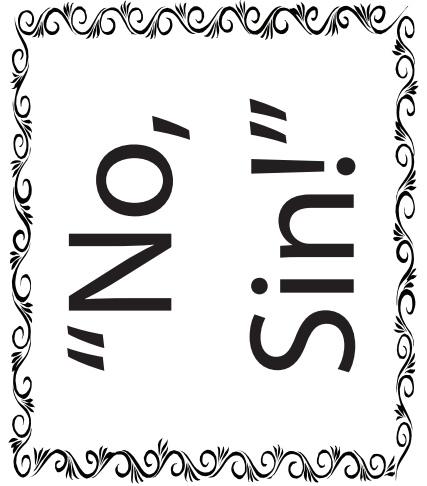
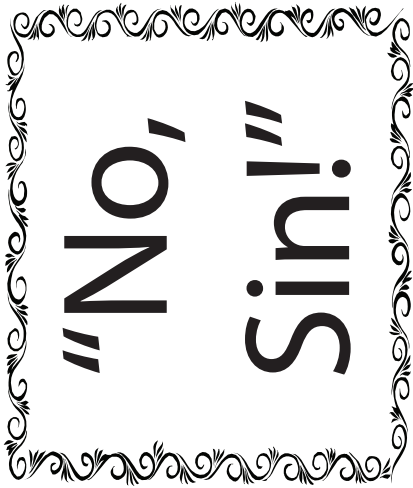

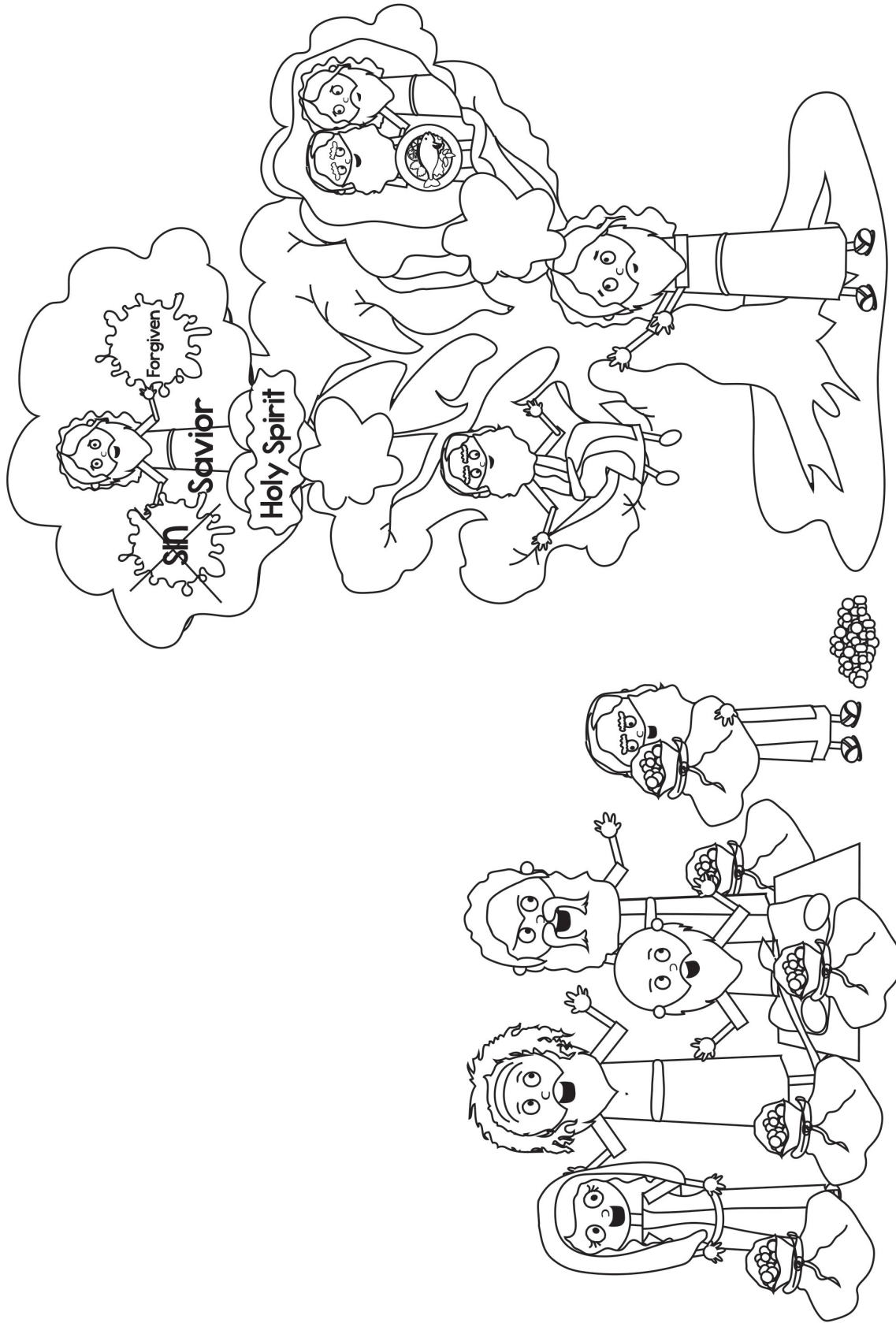

How Can We Be Saved? It Is God's Free Gift... When We Tell God Our Sins and Turn Away from Them! Not just people like Zacchaeus who do lots of bad things need to be saved. We all do! For we all have chosen to disobey God and we all deserve God's punishment for our sins. What good news we have, though! God promises to save all who turn away from disobeying Him and trust in Jesus as their Savior, even you and me! Let's ask God to work in our hearts, just like He worked in Zacchaeus' heart. Let's ask Him to help us to turn away from disobeying Him and trust in Jesus as our Savior, so that we, too, might be saved.

**CAN YOU GUESS BIBLE TRUTH 2:
How Can We Be Saved?
It Is God's Free Gift...**

When We Trust in

As Our Own Savior!"

HINT: What's the name of God's Son? His name starts with a "J" and it sounds like "sneezes."

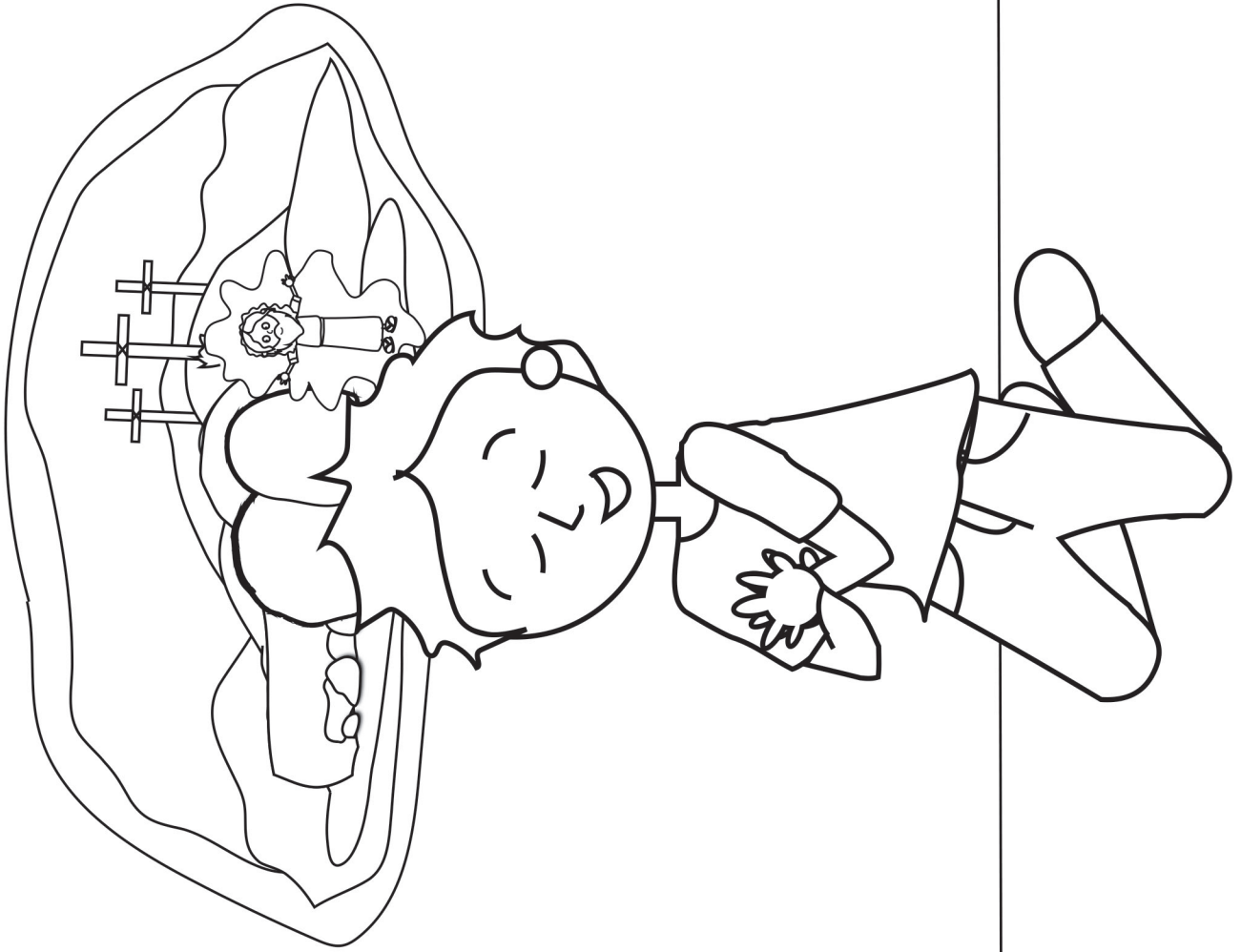

Deep Down Detective Devotion: Unit 11, Bible Truth 2, Lesson 1



Big Question 11: How Can We Be Saved?

Answer: It Is God's Free Gift... When We Trust in Jesus as Our Own Savior!

Bible Truth 2 Meaning

God created us to love and obey Him, but we have all chosen to disobey Him. That's why we all deserve His punishment, instead of His friendship. Our sins separate us from Him. God would be fair to punish us for our sins, but He has chosen to be so kind to us. He offers to forgive our sins and make us His people through Jesus, His Son. Jesus came to earth and lived a perfect life. He never, ever disobeyed God. Then on the cross, Jesus chose to offer up His perfect life as the perfect sacrifice for the sins of God's people. He took the punishment for sins they deserved to save them from their sins. Jesus died on the cross and was buried in a grave, but He didn't stay there. He had beaten sin and death for God's people. He rose from the dead in victory, never to die again! Now, all who turn away from their sins and trust in Jesus as their Savior, are forgiven their sins. They are God's people who know Him in their hearts by His Holy Spirit. And when they die, they will go to live perfectly happy with Him forever. This wonderful, free gift can be ours, too, when we turn away from our sins and trust in Jesus as our own Savior. Isn't that wonderful news!

How do I know this is true? The Bible tells me so!

"If you confess with your mouth that Jesus is Lord and believe in your heart that God raised him from the dead, you will be saved. For with the heart one believes and is justified, and with the mouth one confesses and is saved."

--Romans 10: 9-10, ESV

Some Questions for You

1. God created us to do what? *To love and obey Him perfectly.*
2. Do we love and obey God perfectly? *No, we do not. We have all chosen to disobey Him.*
3. Do we deserve special closeness with God? *No.*
4. What do we deserve from God? *His punishment for our sins.*
5. What does God give His people that is better than they deserve? *He sent Jesus to take the punishment for their sins so that they could be saved.*
6. How can we become God's people and receive the free gift of salvation? *By turning away from our sins and trusting in Jesus as our Savior. God loves to answer this prayer!*

Let's Pray!

- A** God, we praise You for being good and just. We honor You as the One we should all obey.
- C** God, we confess that we are all sinners who have disobeyed You. We know that we can never deserve to be Your people by good things we do. We need a Savior!
- T** Thank You, God, for sending Jesus as the Savior we need. Thank You that He made the way for us to become Your people with His perfect life given as the full payment for the sins of God's people.
- S** God, work in our hearts. Help us to confess our sins to You and turn away from them. Help us to trust in Jesus as our Savior. Help us to know and love You. Help us to live for You. In Jesus' name we pray, Amen.

Let's Sing about What We're Learning!

Big Q & A 11 Song from *Deep Down Detectives* ESV Songs 11, track 12

(adapted version of "Here We Go Looby Loo")

How can we be saved?
 How can we be saved?
 How can we be saved?
 It is God's free gift!

Big Question 11 Action Rhyme Song from *Deep Down Detectives* ESV Songs 11, track 13

Refrain:

How can we be saved?
 How can we be saved?
 How can we be saved?
 It's God' free gift.
 How can we be saved?
 How can we be saved?
 How can we be saved?
 How can we be saved?
 It's God's free gift through Christ.

Verse 1

I disobey God, I need a Savior,
 You disobey God, You need a Savior,
 We all disobey God, We need a Savior.
 To save us from our sins. *Refrain*

Verse 2

Jesus, He paid the price, the perfect sacrifice,
 On the cross, gave His life,
 Bought us eternal life,
 Takes away all our sin,
 Makes our hearts clean within,
 When we repent and believe in Him. *Refrain*

Go to the *Deep Down Detectives* Parent Resources for Unit 11 to get the Bible story and many more resources and songs for this unit at praisefactory.org

**“If you confess with your mouth that Jesus is Lord
and believe in your heart that God raised him from the dead,
you will be saved.**

**For with the heart one believes and is justified,
and with the mouth one confesses and is saved.”**

--Romans 10:9-10, ESV

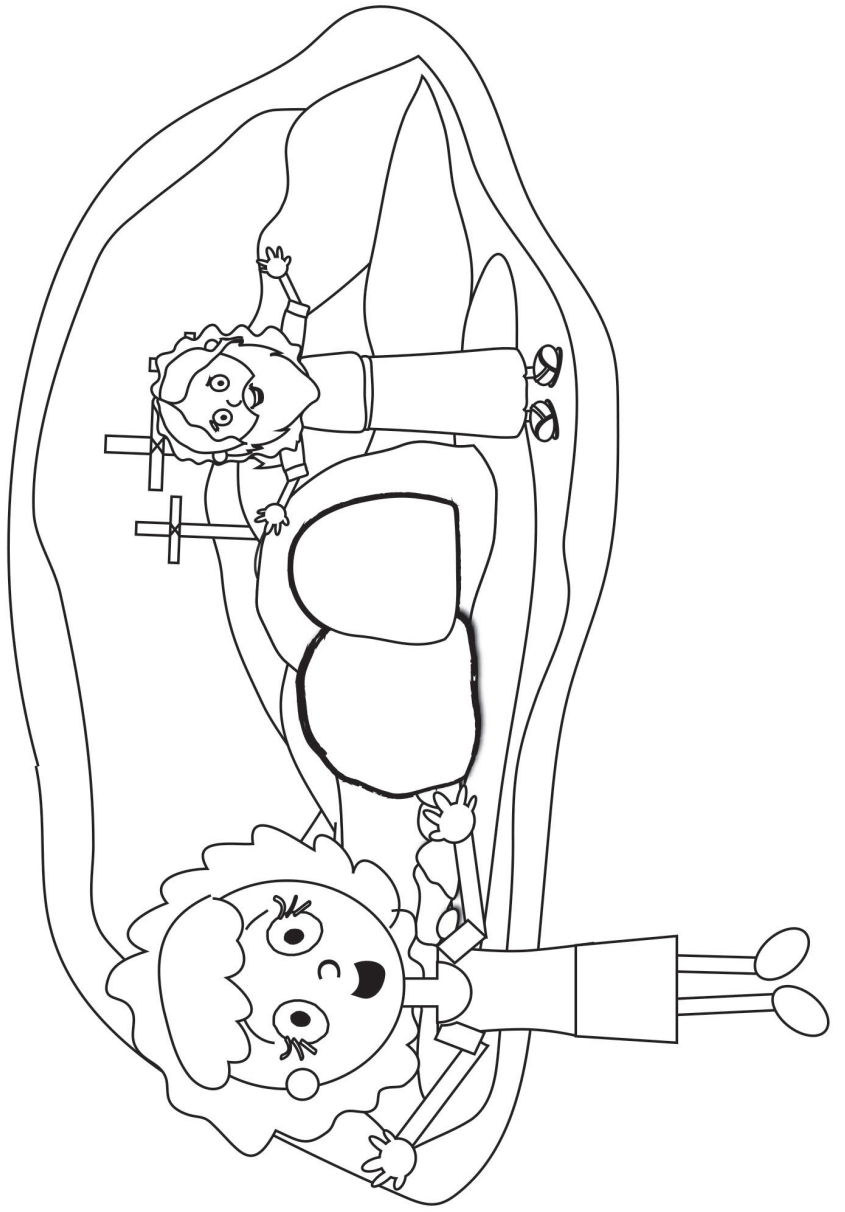
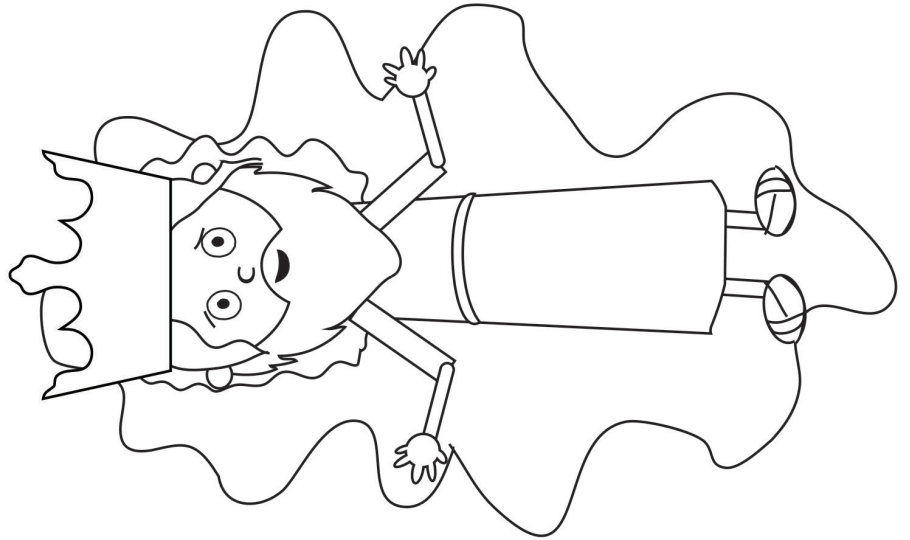

Deep Down Detective Devotion: Unit 11, Bible Truth 2, Lesson 2



Big Question 11: How Can We Be Saved?

Answer: It Is God's Free Gift... When We Trust in Jesus as Our Own Savior!

How do I know this is true? The Bible tells me so:

"If you confess with your mouth that Jesus is Lord and believe in your heart that God raised him from the dead, you will be saved. For with the heart one believes and is justified, and with the mouth one confesses and is saved."

--Romans 10:9-10, ESV

Learn a Little: "If you confess Jesus is Lord and believe that God raised him from the dead, you will be saved."

Meaning:

To believe something in your heart is to think that something is true. To confess something is to tell others what you think is true. Christians are those who believe in their hearts that Jesus is the Son of God, who died on the cross to save God's people from their sins. They believe that He rose from the dead on the third day, showing that He had beaten sin and death for them. They love telling this good news to others that they might believe and be saved, too. We must believe in our own hearts that He is our Savior and be willing to confess to others that He is our Lord, if we are to be saved, too!

Some Questions for You

1. What does it mean to believe something in your heart? *To think that it is true.*
2. What does it mean to confess something? *To tell others what you think is true.*
3. Who do Christians believe in their heart is Lord? What does that mean? *They believe Jesus is Lord. They believe He is the Son of God who we should all obey.*
4. What amazing thing do they believe Jesus did? *He died on the cross for the sins of God's people and on the third day, God raised Him from the dead. He beat sin and death for God's people!*
5. How can Jesus become our Savior? *When we turn from our sins and trust in Him as our Savior.*

Let's Pray!

- A** God, we praise You for being good and just. We honor You as the One we should all obey.
- C** God, we confess that we are all sinners who have disobeyed You. We know that we can never deserve to be Your people by good things we do. We need a Savior!
- T** Thank You, God, for sending Jesus as the Savior we need. Thank You that He made the way for us to become Your people with His perfect life given as the full payment for the sins of God's people.
- S** God, work in our hearts. Help us to confess our sins to You and turn away from them. Help us to trust in Jesus as our Savior. Help us to know and love You. Help us to live for You. In Jesus' name we pray, Amen.

Let's Sing Our Bible Verse!

If You Confess with Your Mouth: Romans 1:9-10

from Deep Down Detectives ESV Songs 11, track 19

If you confess, with your mouth, "Jesus is Lord,"
And believe in your heart,
That God raised Him from the dead,
You will be saved, you will be saved.
For with the heart, one believes and is justified.

If you confess, with your mouth, "Jesus is Lord,"
And believe in your heart,
That God raised Him from the dead,
You will be saved, you will be saved.
For with the mouth, one confesses and is saved.
Romans Ten: nine through ten.

Go to te Deep Down Detectives Parent Resources for Unit 11 to get the Bible story and many more resources and songs for this unit at praisefactory.org

Which four of these clues belong in our story? Which two do not? Put an X in the boxes of the four that belong.

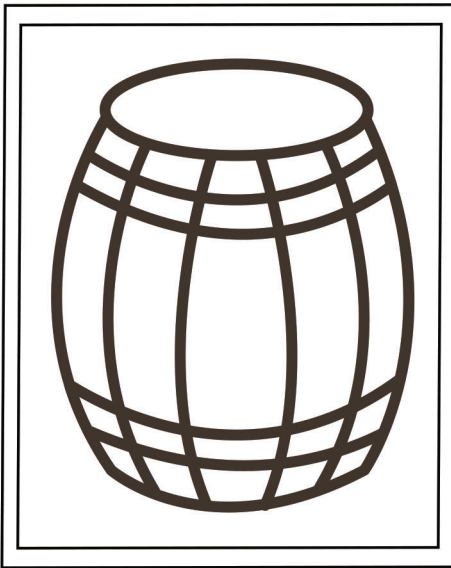

A Barrel

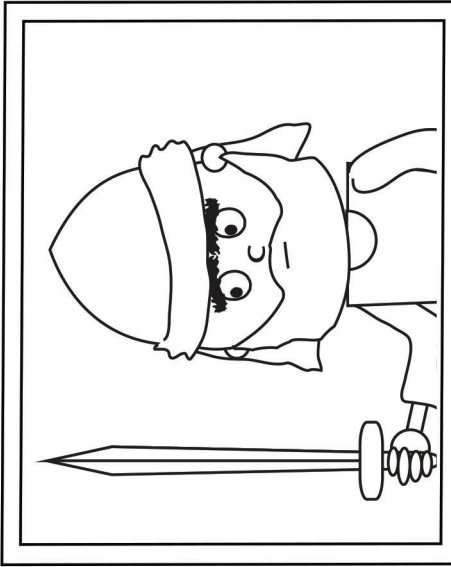

A Soldier

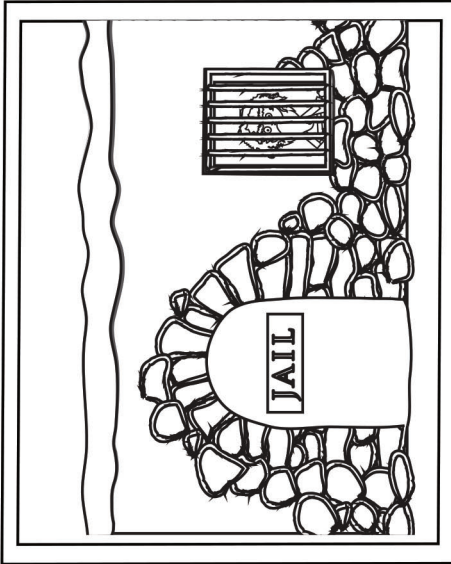

A Jail

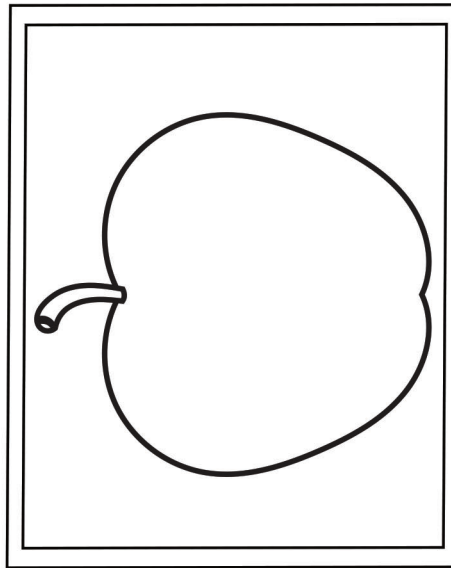

An Apple

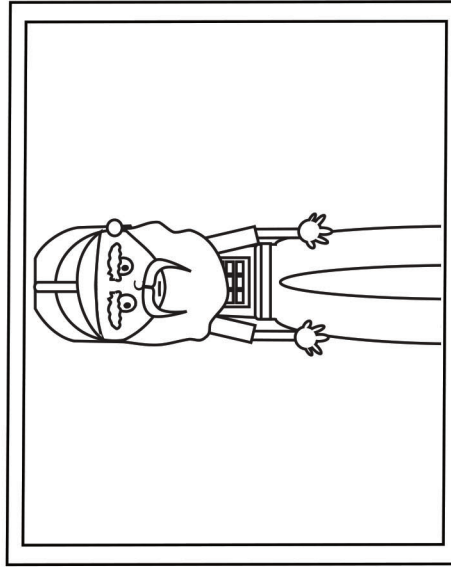

A High Priest

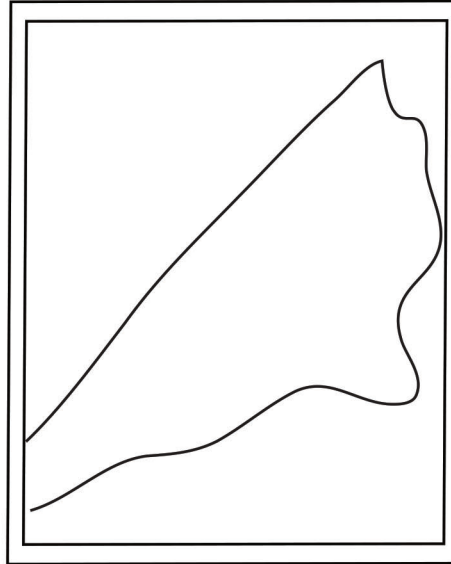

A Bright Light

Answer: The soldier, the jail, the high priest and the bright light belong. The barrel and the apple do not.

Deep Down Detective Devotion: Unit 11, Bible Truth 2, Lesson 3



Big Question 11: How Can We Be Saved?

Answer: It Is God's Free Gift... When We Trust in Jesus as Our Own Savior!

Bible Truth 2 Meaning

God created us to love and obey Him, but we have all chosen to disobey Him. That's why we all deserve His punishment, instead of His friendship. Our sins separate us from Him. God would be fair to punish us for our sins, but He has chosen to be so kind to us. He offers to forgive our sins and make us His people through Jesus, His Son. Jesus came to earth and lived a perfect life. He never, ever disobeyed God. Then on the cross, Jesus chose to offer up His perfect life as the perfect sacrifice for the sins of God's people. He took the punishment for sins they deserved to save them from their sins. Jesus died on the cross and was buried in a grave, but He didn't stay there. He had beaten sin and death for God's people. He rose from the dead in victory, never to die again! Now, all who turn away from their sins and trust in Jesus as their Savior, are forgiven their sins. They are God's people who know Him in their hearts by His Holy Spirit. And when they die, they will go to live perfectly happy with Him forever. This wonderful, free gift can be ours, too, when we turn away from our sins and trust in Jesus as our own Savior. Isn't that wonderful news!

How do I know this is true? The Bible tells me so:

"If you confess with your mouth that Jesus is Lord and believe in your heart that God raised him from the dead, you will be saved. For with the heart one believes and is justified, and with the mouth one confesses and is saved."

--Romans 10:9-10, ESV

Some Questions for You

1. What did Jesus' followers do that made Saul so mad? *They told everyone that Jesus died on the cross and rose from the dead to save God's people. They told everyone to turn away from their sins and trust in Jesus as their Savior.*
2. What did Saul tell Jesus' followers to do? *To stop telling people about Jesus.*
3. Why didn't Jesus' followers stop telling others about Jesus? *Because they wanted others to be forgiven their sins and know God.*
4. What did Saul do to Jesus' followers? *He found them, hurt them and had them put in jail.*
5. Why did Jesus' followers move to other cities? *So that Saul couldn't hurt them and so they could tell more people about Jesus.*
6. What happened to Saul when he went to Damascus to get rid of Jesus' followers who had moved there? *Jesus appeared to him on the road. He became blind and was taken to Damascus. He turned away from his sins and trusted in Jesus as his Savior.*
7. What did Saul start doing after he became a follower of Jesus? *He went and told everyone the good news of Jesus, too.*
8. How can we be saved from our sins, like Saul was? *By turning away from our sins and trusting in Jesus as our Savior.*

Let's Pray!

- A** God, we praise You for being good and just. We honor You as the One we should all obey.
- C** God, we confess that we are all sinners who have disobeyed You. We know that we can never deserve to be Your people by good things we do. We need a Savior!
- T** Thank You, God, for sending Jesus as the Savior we need. Thank You that He made the way for us to become Your people with His perfect life given as the full payment for the sins of God's people.
- S** God, work in our hearts. Help us to confess our sins to You and turn away from them. Help us to trust in Jesus as our Savior. Help us to know and love You. Help us to live for You. In Jesus' name we pray, Amen.

Let's Praise God Right Now!

Big Question 11 Hymn: Grace that Is Greater than All Our Sin from *Deep Down Detectives* ESV Songs 11, track 15

Verse 1

Grace, grace, God's grace,
Grace that will pardon and cleanse within;
Grace, grace, God's grace,
Grace that is greater than all our sin.

Words: Julie H. Johnston Music: Daniel B. Towner

Go to the *Deep Down Detectives* Parent Resources for Unit 11 to get the Bible story and many more resources and songs for this unit at praisefactory.org

Big Question 11 Praise Song: Blessed Be the Name from *Deep Down Detectives* ESV Songs 11, track 16

All praise to Him who reigns above	Blessed be the name,
In majesty supreme.	Blessed be the name,
Who gave His Son for man to die,	Blessed be the name of the Lord;
That He might man redeem!	Blessed be the name,
	Blessed be the name,
	Blessed be the name of the Lord.

Deep Down Devotions: Unit 11, Bible Truth 2 Story Concepts**P.1****The Case of the Amazed, Mad Man***Acts 8-9*

Dear Parents,

Big Question #11 is: "How Can We Be Saved?" Your child is learning that "It Is God's Free Gift... When We Trust in Jesus as Our Own Savior."

Here's a copy of the Bible story they are learning along with the "Listening Assignment" for each lesson. These assignments provide a different teaching emphasis for each lesson, helping the children dig deeper into each Bible truth. They match up with your child's take home for each lesson. We hope that these resources help your family to dig down deeper into the truths of God's Word!" Happy digging!

•many more resources for this Big Question can be found online at www.praisefactory.org•

Listening Assignments

"Hey, Kids! Detective Dan, here. Listen carefully to the story and help me answer these questions:

Detective Dan's Lesson #1 Listening Assignment:

I need to know:

- 1. Who was the man who was so mad? What was he so mad about?**
- 2. What amazing thing happened to him? How did he change when it happened?**

Detective Dan's Lesson #2 Listening Assignment:**Our Bible Verse is Romans 10:9-10, ESV**

"If you confess with your mouth that Jesus is Lord and believe in your heart that God raised him from the dead, you will be saved. For with the heart one believes and is justified, and with the mouth one confesses and is saved."

I need to know:

- 1. Who told people to stop saying Jesus is the Savior?**
- 2. Why did he change his mind?**

Detective Dan's Lesson #3 Listening Assignment:I found six clues, but two of them are **NOT** in the story.

They are: a barrel, a soldier, a jail, an apple, a high priest, and a bright light.

Hold each of them up for the children to see as you identify them.

I need to know:

- 1. Which four belong in the story and which two don't?**
- 2. What surprising person praised Jesus for being God's Son, the Savior?**

Read the assignment questions, THEN SAY,

"Ok, Deep Down Detectives! Put on your best listening ears and see if you can hear the answers to Detective Dan's questions. When I finish telling the story, we will see if we can answer all the questions."

Read the Bible Truth story, answer questions, present the gospel and lead in prayer.

Answers to questions; the gospel; and, ACTS prayer are included with the story text.

The Case of the Amazed, Mad Man Acts 8-9*Story with lines separating paragraphs (text in bold, optional interaction cues in italics)*

Jesus' followers had good news to tell the people of Jerusalem: "Jesus is God's Son. He died on the cross to pay for the sins of God's people. On Day Three, He rose from the dead, beating sin and death for them," they said. "Turn away from disobeying God. Trust in Jesus as your Savior, and God will forgive your sins. You will be saved!" they exclaimed. "You can become one of God's people, too," they told everyone.

Many people in Jerusalem listened, and they believed. They turned away from their sins and trusted in Jesus as their own Savior. God forgave their sins and saved them. How happy they were to become God's people!

But some people listened to Jesus' friends and they were NOT happy. They were mad. Saul was one of those mad people. He HATED people who believed in Jesus.

"Be quiet! Stop saying Jesus is God's Son! Stop saying He died on the cross for the sins of God's people and rose from the dead! Stop saying He's the Savior," Saul told Jesus' followers. "Jesus is just a fake!" he exclaimed. "You are all wrong. And if you don't stop telling people about Jesus, I'm going to have you hurt and put you in jail," he warned them. Oh, no! What would Jesus' followers do now?

What do you think they did? Did they stop telling others about Jesus?

But no matter what Saul said, Jesus' followers didn't stop. They kept spreading the good news of Jesus. They kept urging everyone to turn away from their sins and trust in Him as their Savior. Uh, oh! NOW, what would Saul do?

What do you think he did?

Saul did exactly what he said he would do. He went from house to house with soldiers to arrest them. "Bang, bang, bang!" they knocked on the door. "Open up!" Saul and the soldiers dragged Jesus' followers out of their houses. They hurt them and put them in jail.

Saul kept making it hard to tell the good news of Jesus in Jerusalem, but even this was part of God's plan. "Jesus told us to tell the whole world about Him," Jesus' followers remembered. "Now it's time to go. A few of us will stay here in Jerusalem, but everyone else should move away to other cities," they decided. "People in those cities need to hear the good news of Jesus, too."

So, they packed up their things and moved to other cities. Some went to nearby cities. Others went to faraway cities. But wherever they went, they told everyone the gospel, the good news of Jesus.

Can you tell me the gospel, the good news about Jesus?

"Jesus is God's Son. He died on the cross to pay for the sins of God's people," they told everyone. "Then, on the third day, Jesus rose from the dead. He beat sin and death for God's people!" they explained. "So, turn away from your sins! Trust in Jesus as your Savior! God will forgive your sins and make you one of His people, too. You will be saved!" they exclaimed.

Story with lines separating paragraphs (text in bold, optional interaction cues in italics)

What good news this was! Many people in these cities listened and received the gospel with joy. They turned away from their sins and trusted in Jesus as their Savior. How happy Jesus' followers were to see the people in these new cities believing in Jesus, too!

But there was someone who was very angry when he heard about this. Can you guess who it was?

Can you guess?

It was Saul! He heard what was going on and he was furious! "I will stop these Christians," he vowed. So, Saul went to the high priest, the leader of Jesus' enemies, and said, "If you give me men to go to these other cities, I will arrest the Christians. I will bring them back to Jerusalem and put them in jail. I will stop them," Saul promised.

The high priest agreed. He gave Saul men to help him arrest the Christians in these other cities. Saul was pleased.

"March, march, march!" Saul and the men headed straight for the first city: Damascus. Saul could hardly wait to arrest those Christians and put them in jail! Now, he would stop all this talk about Jesus... or would he?

What do you think happened to Saul next?

Well, as it turned out, God, Himself, had very, very different plans for Saul. God was about change Saul's life completely. He would use Saul to spread the gospel, not stop it. Saul believed Jesus was a fake; but, of course, He wasn't. Jesus was the REAL Son of God. He really died on the cross and rose from the dead, beating sin and death for God's people.

And now, God was going to give Saul the gift of faith in Jesus. He would make Saul one of His people, then use Saul to spread the good news to many. Aren't God's plans amazing?

But how would Saul, a man who HATED Jesus and His followers, change into someone who trusted Jesus as his own Savior? God chose to change Saul in a most amazing way.

Just as Saul and the men were almost to Damascus, a light from heaven, much brighter than the sun, suddenly shone down on them. Saul shut his eyes tight and he fell to the ground. Then, he heard a voice saying to him, "Saul, Saul, why are you hurting me?"

Who are you, Lord?" Saul asked.

Who are you, Lord?" Saul asked. "I am Jesus, whom you are hurting," Jesus told Saul. "But get up now and go to Damascus and you will be told what to do."

The men with Saul stood there speechless; they heard the voice, but didn't see anyone. The bright, heavenly light vanished as quickly as it came, but not without leaving Saul with a problem. When he stood up and went to open his eyes, he couldn't see anything. Saul was blind!

Story with lines separating paragraphs (text in bold, optional interaction cues in italics)

The men took Saul by hand the rest of the way to Judas' house in Damascus. For three days, Saul didn't eat or drink. He just prayed and thought about everything Jesus said. Now, Saul knew the truth. He thought Jesus was a fake, and His believers were wrong. Now, Saul knew HE was the one who was wrong. Jesus WAS the Savior. He WAS God's Son. And Jesus' followers, they were GOD'S people!

Oh my! He had been hurting God's people! Saul knew he deserved God's punishment for all the terrible things he had done. But as Saul prayed, he asked God for more than he deserved. He asked for forgiveness. And what did God do? God helped Saul turn away from his sins and trust in Jesus as his own Savior. Saul was forgiven! He was saved! How kind God is to sinners like Saul, and like us!

Do you think God forgave Saul?

And sure enough, God gave Saul just what he prayed for. God helped Saul to turn away from disobeying God and to trust in Jesus as his own Savior. How kind God is to sinners like Saul...and like us!

After three days, God sent a Christian named Ananias to Saul. "Brother Saul, Jesus, who appeared to you, has sent me so you may see again and be filled with the Holy Spirit," he told Saul. Ananias laid his hands on Saul and something like scales fell off his eyes. God had healed him! But what happened next was even better: God's Holy Spirit came to live in Saul's heart.

Saul was so happy. God had saved him from his sins through Jesus. God had made Saul one of His people. Saul was a new man! Saul got up and was baptized as a sign that he was beginning a new life of living for God, with Jesus as his Savior. Then, Saul went out and did something else. Something he never, ever dreamed he would do. Can you guess what he did?

Can you guess?

Saul went out to tell the good news of Jesus to the people of Damascus. "Jesus is God's Son. He died on the cross to pay for the sins of God's people," Saul told them. "On the third day, He rose from the dead. He beat sin and death for God's people!" he exclaimed. "Turn away from disobeying God! Trust in Jesus as your Savior. God will forgive your sins and save you. You can be one of God's people!"

How surprised the people were! "Wasn't this the man who hated Jesus and His followers? Wasn't this the man who hurt them and put them in jail? And now HE is one of THEM!" they exclaimed. And as Saul preached about Jesus, the Holy Spirit worked in the hearts of many. They turned away from their sins and trusted in Jesus as their Savior.

Yes, all of God's good plans were coming true. His good plans for Saul and His good plans for the many others, who would trust in Jesus as their Savior through Saul's message. How amazing God is!

Cracking the Case: (story wrap-up for Listening Assignments)

It's time to see how we did with our Listening Assignment.

Detective Dan's Lesson #1 Listening Assignment:

1. Who was the man who was so mad? What was he so mad about? Saul. He was mad that Jesus' followers were telling people to trust in Jesus as their Savior.

2. What amazing thing happened to him? How did he change when it happened? Jesus appeared to Saul and Saul knew that He really was the Savior. Saul turned away from his sins and trusted in Jesus as his Savior. He started telling everyone the good news of Jesus.

For You and Me:

God turned Saul from a man who hated Jesus and wanted to hurt God's people, to someone who loved Jesus and served Him his whole life. God can work powerfully in our lives, too, when we turn away from our sins and trust in Jesus as our Savior.

Detective Dan's Lesson #2 Listening Assignment:**Our Bible Verse is Romans 10:9-10, ESV**

"If you confess with your mouth that Jesus is Lord and believe in your heart that God raised him from the dead, you will be saved. For with the heart one believes and is justified, and with the mouth one confesses and is saved."

I need to know:

1. Who told people to stop saying Jesus is the Savior? Saul did.

2. Why did he change his mind? Jesus appeared to Saul and Saul knew that He really was the Savior. Saul turned away from his sins and trusted in Jesus as his Savior.

For You and Me:

How amazing it is that God could change someone like Saul from a man who hated Jesus to a man who loved Him and trusted in Him as his Savior. God can change as to when we turn away from our sins and trust in Jesus as our Savior.

Detective Dan's Lesson #3 Listening Assignment:

I found six clues, but two of them are **NOT** in the story. They are: a drum, a Pharisee, a golden box, a sick man, the Temple, and a bag of money.

Hold each of them up for the children to see as you identify them.

I need to know:

1. Which four belong in the story and which two don't? The soldier, the jail, the high priest and the bright light belong. The barrel and the apple do not.

2. What surprising person praised Jesus for being God's Son, the Savior? What did God do for this man? Saul did. God showed him that Jesus really was the Son of God. He helped him to turn away from his sins and trust in Jesus as his Savior. God forgave his sins!

For You and Me:

Everyone was so surprised to see Saul change from a man who hated Jesus to a man who loved him and trusted in him as his Savior! God is able to change the heart of anyone! He's able to change our hearts to, ask him to change your heart! Ask him to help you turn away from your sins and trust in Jesus as your Savior. He loves to answer this prayer!

The Gospel (story wrap-up if NOT using Listening Assignments)**Our Bible Truth is:****How Can We Be Saved?****It Is God's Free Gift...****When We Trust in Jesus as Our Own Savior!**

How kind God was to save Saul! Saul had hated had hated God's people and he had hated the good news of Jesus. He had done terribly mean things. But, oh, how God had loved Saul anyway! He came to Saul in a special way. He worked in Saul's heart, helping him to turn away from disobeying God and trust in Jesus as His own Savior. God chose to have Jesus appear to Saul to help Saul believe in Him. He changed Saul's life and made him one of His people!

But God doesn't need to do such amazing things to change our hearts. If we ask Him, He will send the Holy Spirit to work in our hearts. He can help us to turn away from disobeying God and help us to trust in Jesus as our Savior. Then, we will be God's people, too.

Close in prayer.

Closing ACTS Prayer

- A** God, we praise You for being good and just. We honor You as the One we should all obey.
- C** God, we confess that we are all sinners who have disobeyed You. We know that we can never deserve to be Your people by good things we do. We need a Savior!
- T** Thank You, God, for sending Jesus as the Savior we need. Thank You that He made the way for us to become Your people with His perfect life given as the full payment for the sins of God's people.
- S** God, work in our hearts. Help us to confess our sins to You and turn away from them. Help us to trust in Jesus as our Savior that we might become Your people. Help us to know and love You. Help us to live for You.

In Jesus' name we pray, Amen.

Deep Down Detectives Devotions: Big Question 11, Bible Truth 2 Key Concepts P.7**Unit 11: The God Who Saves**

Unit Big Question (and Answer): How Can We Be Saved? It Is God's Free Gift!

Unit Bible Verse: "For the wages of sin is death, but the free gift of God is eternal life in Christ Jesus our Lord."

--- Romans 6:23, ESV

Bible Truth 2 Concept: It Is God's Free Gift... When We Trust in Jesus as Our Own Savior!

God created us to love and obey Him, but we have all chosen to disobey Him. That's why we all deserve His punishment, instead of His friendship. Our sins separate us from Him. God would be fair to punish us for our sins, but He has chosen to be so kind to us. He offers to forgive our sins and make us His people through Jesus, His Son.

Jesus came to earth and lived a perfect life. He never, ever disobeyed God. Then on the cross, Jesus chose to offer up His perfect life as the perfect sacrifice for the sins of God's people. He took the punishment for sins they deserved to save them from their sins.

Jesus died on the cross and was buried in a grave, but He didn't stay there. He had beaten sin and death for God's people. He rose from the dead in victory, never to die again! Now, all who turn away from their sins and trust in Jesus as their Savior, are forgiven their sins. They are God's people who know Him in their hearts by His Holy Spirit. And when they die, they will go to live perfectly happy with Him forever. This wonderful, free gift can be ours, too, when we turn away from our sins and trust in Jesus as our own Savior. Isn't that wonderful news!

Bible Truth 2 Bible Verse: Romans 10:9-10

"If you confess with your mouth that Jesus is Lord and believe in your heart that God raised him from the dead, you will be saved. For with the heart one believes and is justified, and with the mouth one confesses and is saved."

Learn a Little: "If you confess Jesus is Lord and believe that God raised him from the dead, you will be saved."

Meaning

To believe something in your heart is to think that something is true. To confess something is to tell others what you think is true. Christians are those who believe in their hearts that Jesus is the Son of God, who died on the cross to save God's people from their sins. They believe that He rose from the dead on the third day, showing that He had beaten sin and death for them. They love telling this good news to others that they might believe and be saved, too. We must believe in our own hearts that He is our Savior and be willing to confess to others that He is our Lord, if we are to be saved, too!

Bible Truth 2 ACTS Prayer

- A** God, we praise You for being good and just. We honor You as the One we should all obey.
- C** God, we confess that we are all sinners who have disobeyed You. We know that we can never deserve to be Your people by good things we do. We need a Savior!
- T** Thank You, God, for sending Jesus as the Savior we need. Thank You that He made the way for us to become Your people with His perfect life given as the full payment for the sins of God's people.
- S** God, work in our hearts. Help us to confess our sins to You and turn away from them. Help us to trust in Jesus as our Savior that we might become Your people. Help us to know and love You. Help us to live for You. In Jesus' name we pray, Amen.

Big Question 11, Bible Truth 2 Overview: Key Concepts

p.8

Bible Truth 2 Story

The Case of the Amazed, Mad Man Acts 8-9

Songs Used in Bible Truth 2 Songs Used in Bible Truth 2

Big Q & A 11 Song

Big Question 11 Song: How Can I Be Saved?

Big Question 11 Bible Verse Song: The Free Gift of God Is Eternal Life Romans 6:23, ESV

Big Question 11 Hymn: Grace Greater than All Our Sin, refrain

Big Question 11 Praise Song: Blessed Be the Name

Bible Truth 2 Bible Verse Song: If You Confess with Your Mouth Romans 10:9-10, ESV

Extra Bible Truth 2 Verse Song: In My Father's House John 14:2-6, ESV

listen to or download songs for free at <https://praisefactory.org>: Deep Down Detectives Music page

Go and Tell Bible Truth Concept Craft

God's Free Gift of Salvation Through Jesus

Craft Description

The children will decorate cards to remind them that Jesus can be their own Savior.

Materials

White paper or cardstock

Manilla folder, construction paper or craft foam, enough for a 5" x 5" square per craft.

Aluminum foil, reflective silver wrapping paper or craft mirror paper sheets (found at craft stores)

Glitter glue, sequins, other small decorating supplies for decorating frame of mirror, if desired

Markers or crayons

Glue

Preparations

1. Print out the craft pages and make 1 copy per child of them on white paper or preferably, cardstock. Make sure to print the card double-sided to form a two-sided card.
2. Cut out the frame pattern and use it to cut frames out of manila folder, construction paper or craft foam, one per craft.
3. Cut out mirror pattern and use it to cut 5" x 5" mirror squares, one per craft. Glue around back edges of frame and attach it to outer edges of foil. Glue mirror in place below the word "MY" on the left inside panel of the card. (if desired, your older kids may be able to do this with assistance when they make their craft). DO NOT FOLD CARD IN HALF AT THIS POINT!
4. Set out markers/crayons, glue, glitter glue and other decorating supplies.

Introducing the Craft:

"Our Big Question is: "How Can We Be Saved? It Is God's Free Gift...When We Trust in Jesus as Our Own Savior!" That's something very good to know. But many people don't know that. So, do you know what God wants us to do? He wants us to go and tell others this very important news. So today we are going to make something we can show and tell them, too. Here's what it looks like..." (Hold up example of craft)

Directions

1. Show children your finished craft, reading the words to them.
2. Have the children color in the front of the card, then flip the card over to what will be the inside.
3. Have the children color in the cross with markers.
4. If desired, also have the children decorate around their picture frame with the glitter glue, sequins, etc. Let the craft dry.
5. Fold the card in half and make sure to write each child's name on their craft.
6. If you have time, you can practice saying the words on the card and opening it up and showing the answer.

Discussion

This is an especially good time to re-read the key concepts and discuss them. See Deep Down Discussion Sheet for possible questions to talk about.

Craft Wrap-Up:

"At the end of our time together today, you get to take home your Go and Tell crafts. And what are you going to do with them? Show and tell someone the important news you've learned today: "How Can We Be Saved? It Is God's Free Gift...When We Trust in Jesus as Our Own Savior!"

Frame Template

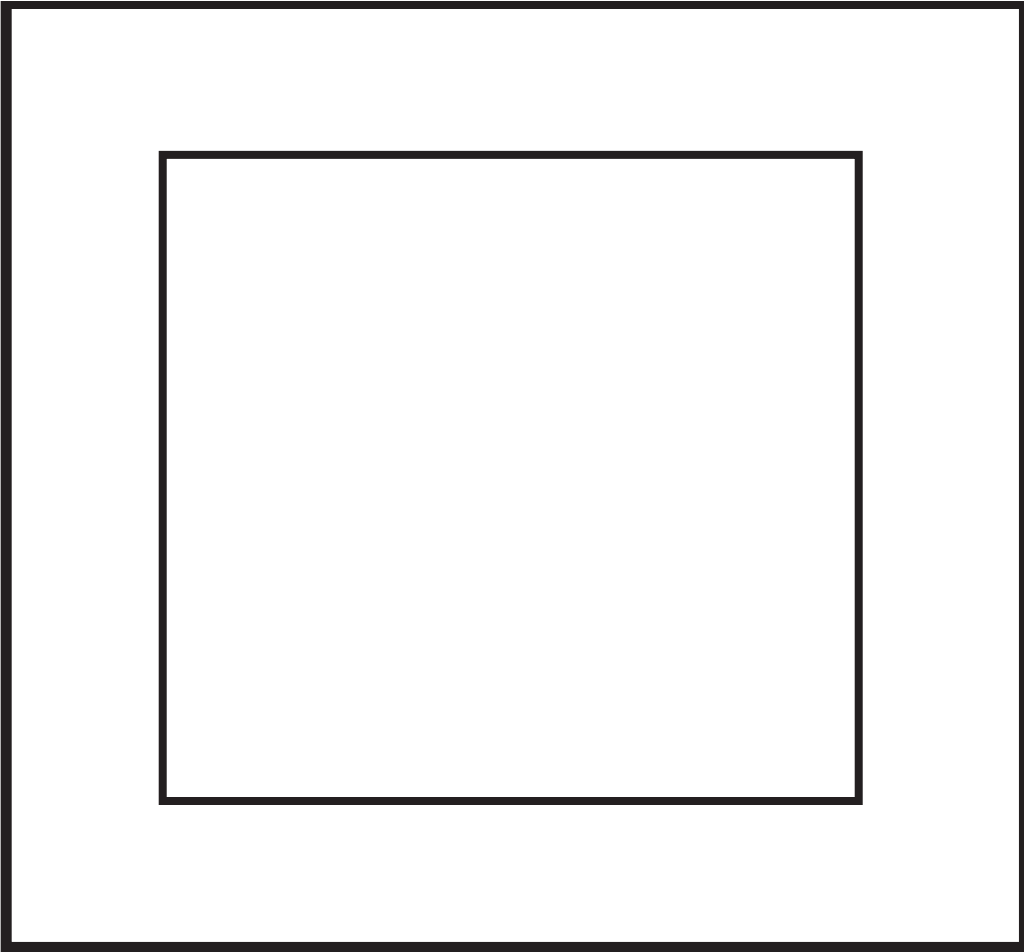

Mirror Template

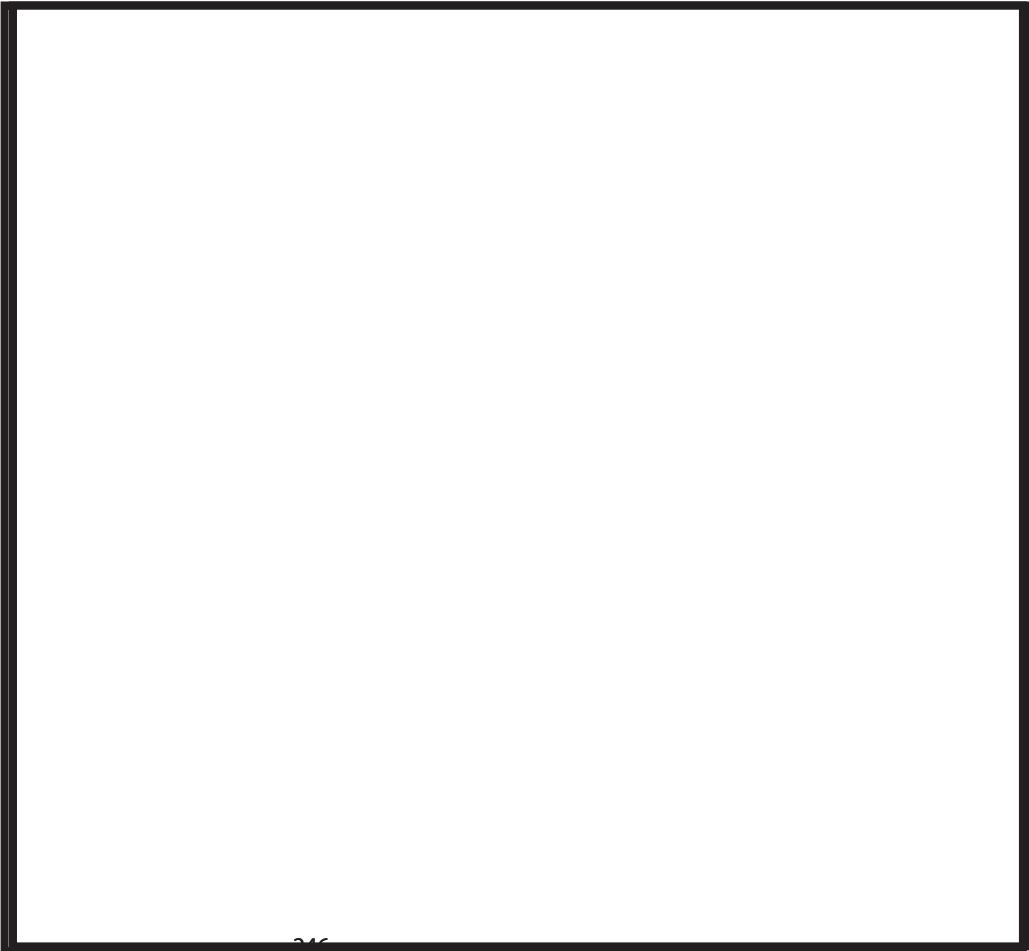

How Can We Be Saved? It is God's Free Gift...

"If you confess with your mouth
that Jesus is Lord
and believe in your heart
that God raised him
from the dead,
you will be saved.
For with the heart one believes
and is justified, and
with the mouth one confesses
and is saved."
Romans 10:9, ESV

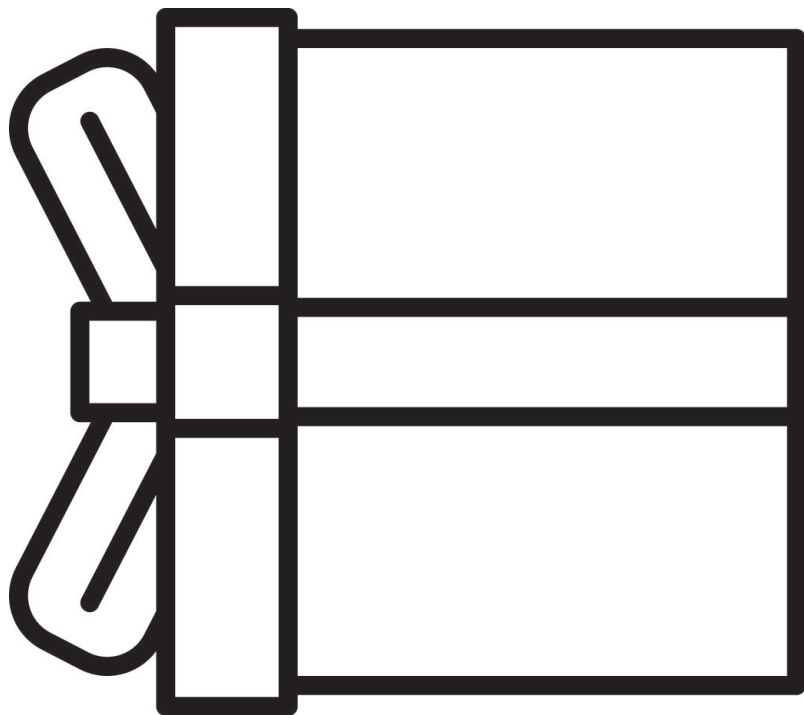

When We Trust in Jesus as Our Own Savior!

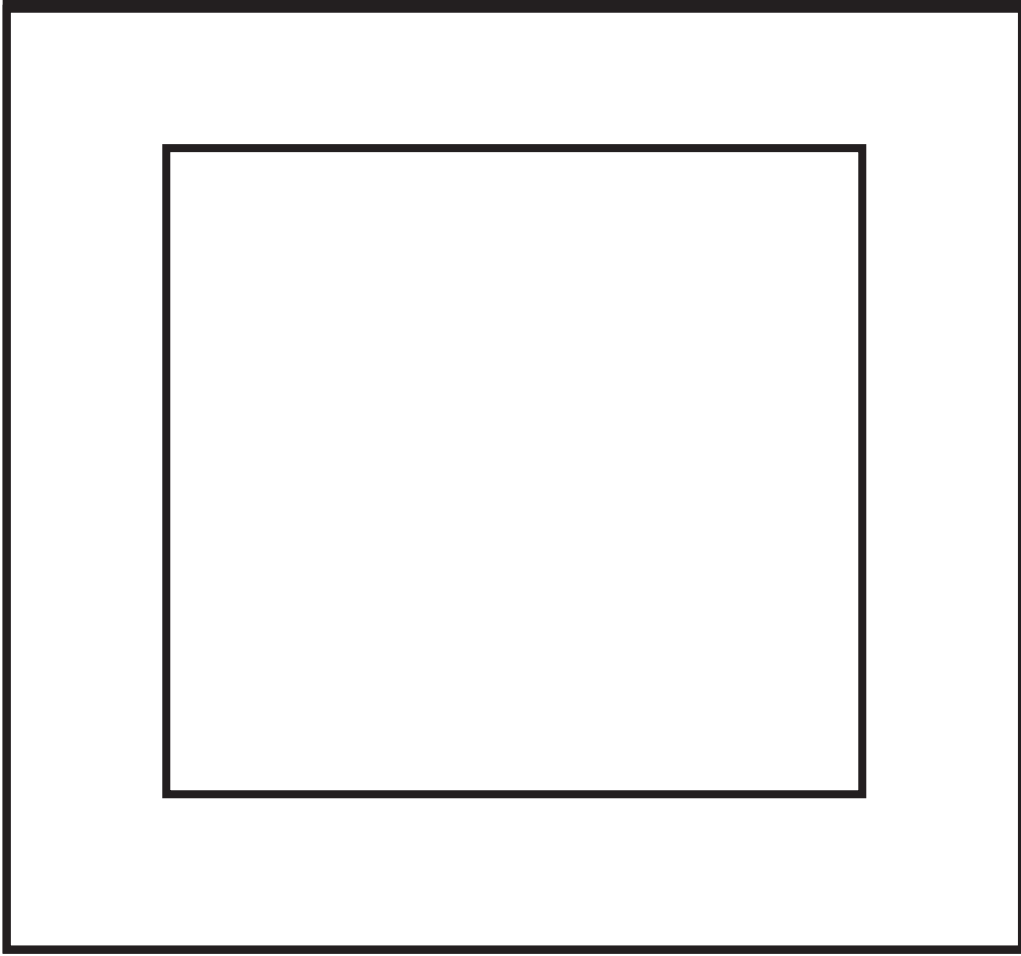

MY

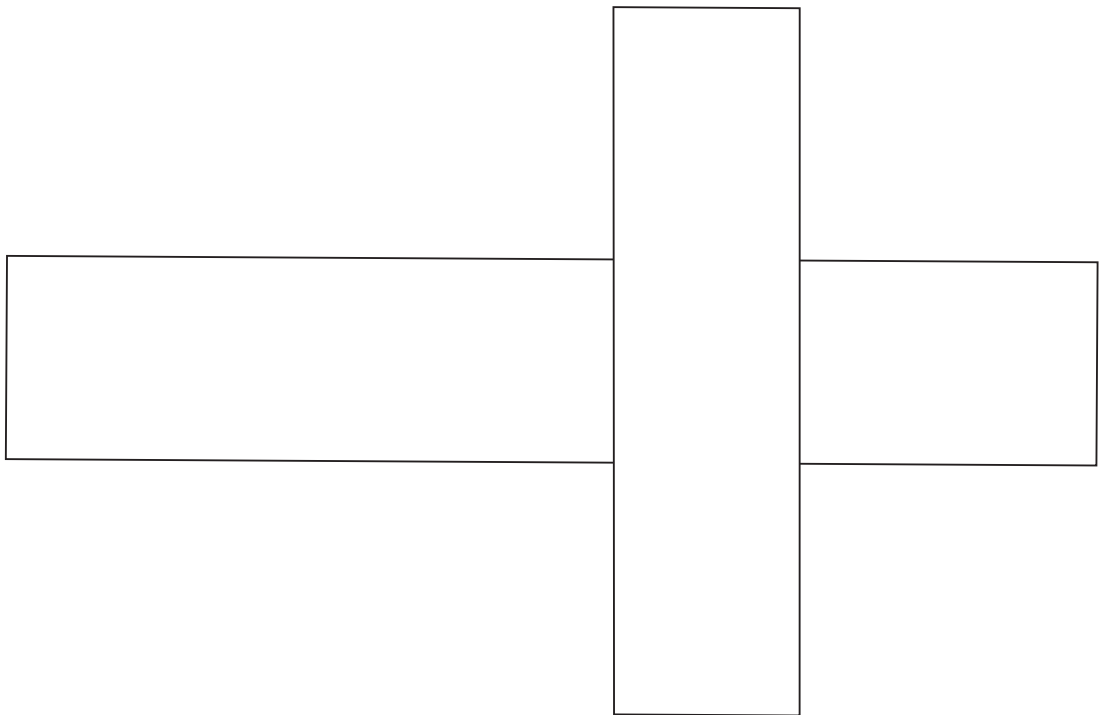

SAVIOR

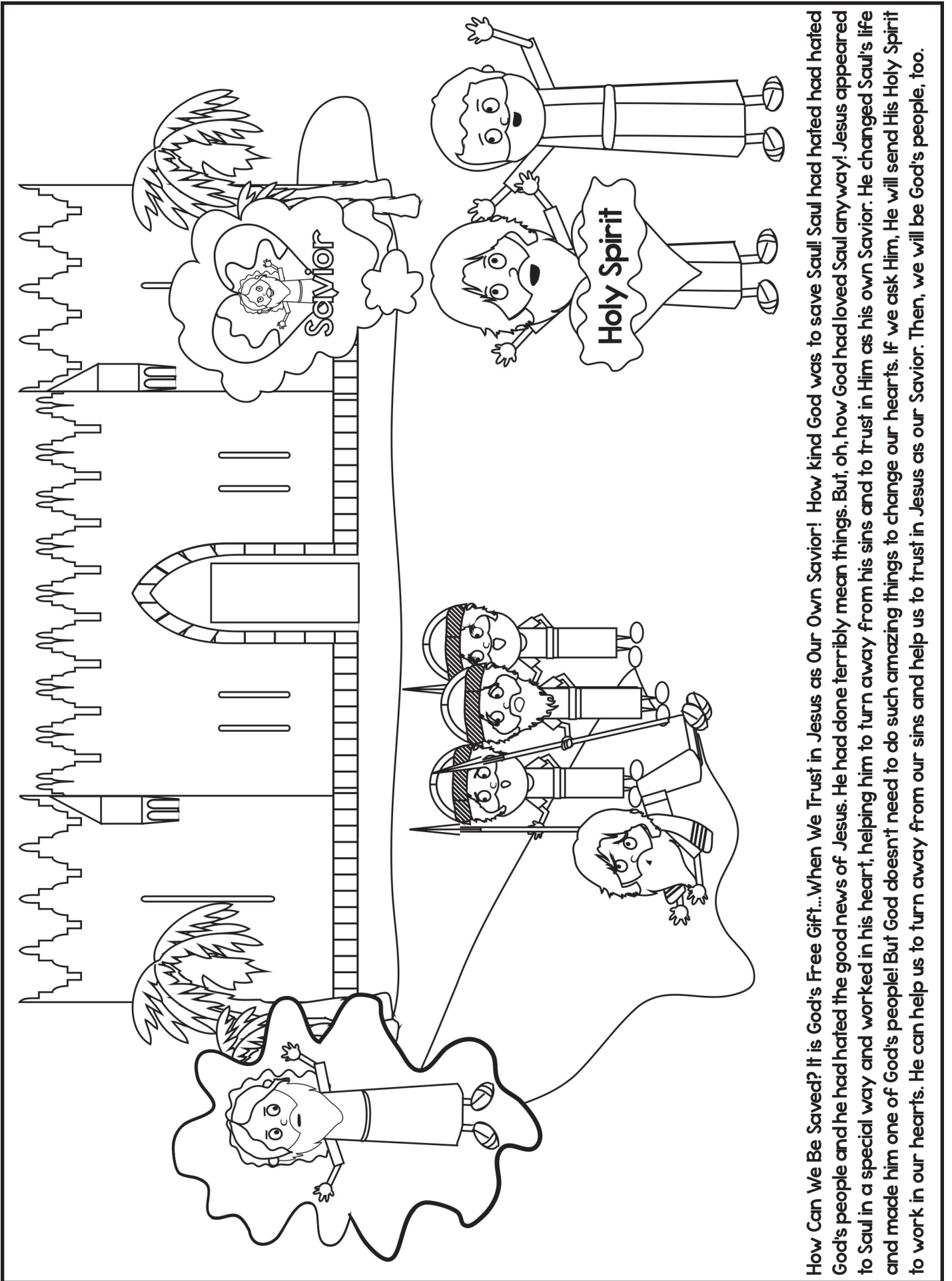

How Can We Be Saved? It is God's Free Gift...When We Trust in Jesus as Our Own Savior! How kind God was to save Saul! Saul had hated had hated God's people and he had hated the good news of Jesus. He had done terribly mean things. But, oh, how God had loved Saul any way! Jesus appeared to Saul in a special way and worked in his heart, helping him to turn away from his sins and to trust in Him as his own Savior. He changed Saul's life and made him one of God's people! But God doesn't need to do such amazing things to change our hearts. If we ask Him, He will send His Holy Spirit to work in our hearts. He can help us to turn away from our sins and help us to trust in Jesus as our Savior. Then, we will be God's people, too.

The Case of the Amazed Mad Man Acts 8-9 Jigsaw Puzzle Page

Make copies of picture and cut out into an appropriate number of pieces for your children.
Or, you can print out color versions of this puzzle by downloading it from praisefactory.org.

How Can We Be Saved? It is God's Free Gift...When We Trust in Jesus as Our Own Savior! How kind God was to save Saul! Saul had hated had hated God's people and he had hated the good news of Jesus. He had done terribly mean things. But, oh, how God had loved Saul anyway! He came to Saul in a special way. He worked in Saul's heart, helping him to turn away from disobeying God and trust in Jesus as His own Savior. God chose to have Jesus appear to Saul to help Saul believe in Him. He changed Saul's life and made him one of His people! But God doesn't need to do such amazing things to change our hearts. If we ask Him, He will send the Holy Spirit to work in our hearts. He can help us to turn away from disobeying God and help us to trust in Jesus as our Savior. Then, we will be God's people, too.

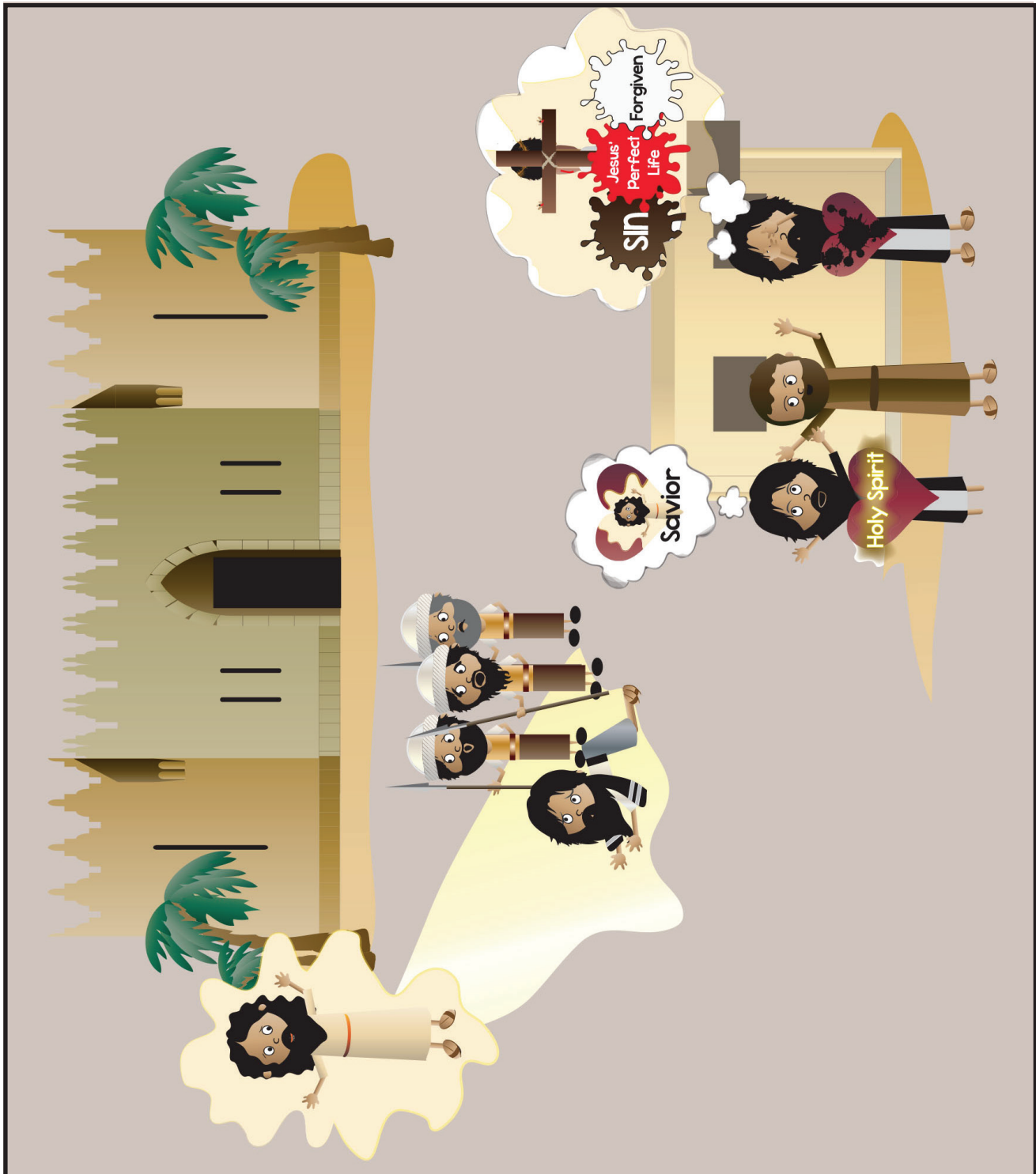

CAN YOU GUESS BIBLE TRUTH 3:

How Can We Be Saved?

It Is God's Free Gift...

When the Holy Spirit Works in Our

----- !

HINT: What did God put deep inside of us

so we can know and love Him?

It starts with an "h" and it rhymes with "starts."

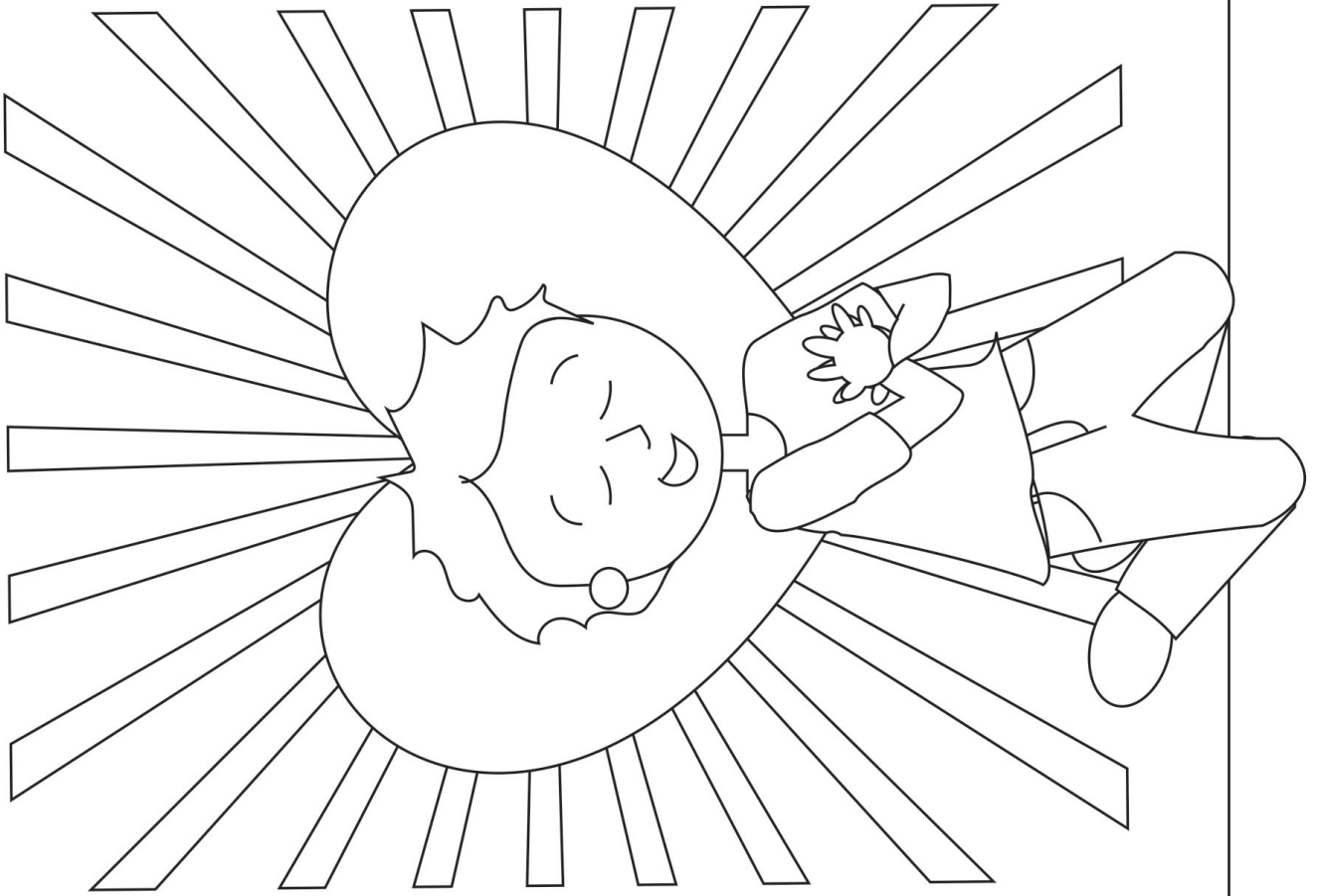

Deep Down Detective Devotion: Unit 11, Bible Truth 3, Lesson 1



Big Question 11: How Can We Be Saved?

Answer: It Is God's Free Gift... When the Holy Spirit Works in Our Hearts!

Bible Truth 3 Meaning

All of us are sinners. We would rather do things our own way rather than obey God. We have hearts that are dead and empty of love for Him and His good ways. We would never choose to love God on our own. But guess what God does for His people? He treats them so much better than they deserve! He sends His Holy Spirit to work in their hearts. When they hear God's Word, He helps them know they are sinners. He helps them want to stop disobeying God and trust in Jesus as their Savior. He makes their hearts alive to God. Now, they know God and want to obey and love Him. We can be God's people, too! We can ask God to send the Holy Spirit to work in our hearts. He can help us to ask God to forgive our sins, trust Jesus as our Savior, and live for Him. Then we can know God in our hearts, now; and when we die, we will go to live perfectly happily with Him forever.

How do I know this is true? The Bible tells me so!

"...He saved us, not because of works done by us in righteousness, but according to his own mercy, by the washing of regeneration and renewal of the Holy Spirit." --Titus 3:5-7, ESV

Some Questions for You

1. Who are sinners? *All of us.*
2. Would we rather do things our way or God's way? *Our way!*
3. What are sinners' hearts empty of? *Love for God and His good ways.*
4. Do sinners choose God on their own? *No, they don't.*
5. Who does God send to work in hearts of His people? *The Holy Spirit.*
6. What does the Holy Spirit do in the hearts of God's people? *Helps them to know they are sinners; helps them want to stop disobeying God; helps them trust Jesus as their Savior.*
7. What book does God use? *His Word, the Bible.*
8. Can we ask the Holy Spirit to work in our hearts? *Yes, we can. He can help us turn away from our sins and trust in Jesus as our Savior.*

Let's Pray!

- A** God, we praise You for being the Changer of the hearts of sinful people, like us.
- C** God, we confess that we are all sinners. We have hard hearts that are slow to believe, love, and obey You. We need Jesus to save us!
- T** Thank You for sending Your Holy Spirit to work in the hearts of people like us, so we can know You, love You, and live for You. You give us what we need but could never get on our own.
- S** God, send the Holy Spirit to work in our hearts. Give us faith as we hear Your Word, the Bible. Help us to turn away from our sins and trust in Jesus as our Savior. Make us new creations! Give us the new birth! We want to know You and live for You! In Jesus' name we pray, Amen.

Let's Sing about What We're Learning!

Big Q & A 11 Song from *Deep Down Detectives ESV Songs 11, track 12*
(adapted version of "Here We Go Looby Loo")

How can we be saved?
How can we be saved?
How can we be saved?
It is God's free gift!

Big Question 11 Action Rhyme Song

 from *Deep Down Detectives ESV Songs 11, track 13*

Refrain:

How can we be saved?
How can we be saved?
How can we be saved?
It's God's free gift.
How can we be saved?
How can we be saved?
How can we be saved?
It's God's free gift through Christ.

Verse 1

I disobey God, I need a Savior,
You disobey God, You need a Savior,
We all disobey God, We need a Savior.
To save us from our sins. *Refrain*

Verse 2

Jesus, He paid the price, the perfect sacrifice,
On the cross, gave His life,
Bought us eternal life,
Takes away all our sin,
Makes our hearts clean within,
When we repent and believe in Him. *Refrain*

“He saved us, not because of works done by us in righteousness, but according to his own mercy, by the washing of regeneration and renewal of the Holy Spirit.” --Titus 3:5-7, ESV

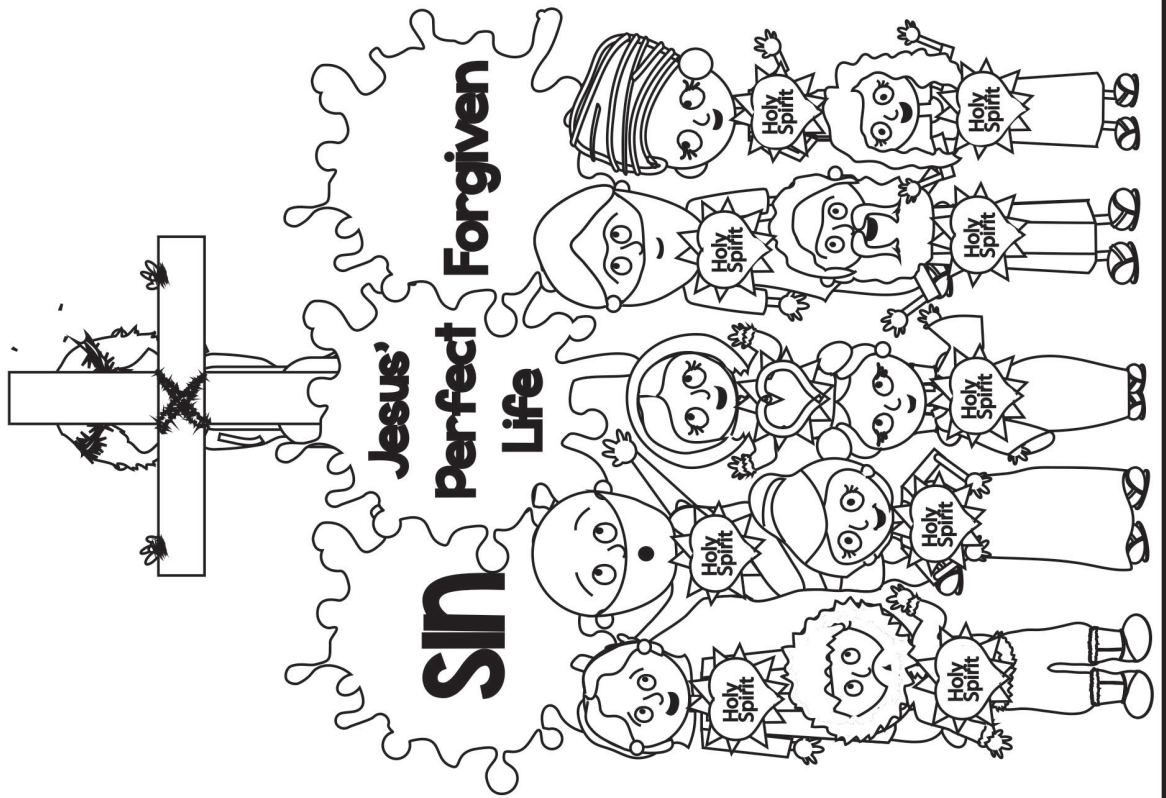

Deep Down Detective Devotion: Unit 11, Bible Truth 3, Lesson 2



Big Question 11: How Can We Be Saved?

Answer: It Is God's Free Gift... When the Holy Spirit Works in Our Hearts!

How do I know this is true? The Bible tells me so!

"...He saved us, not because of works done by us in righteousness, but according to his own mercy, by the washing of regeneration and renewal of the Holy Spirit." --Titus 3:5-7, ESV

Learn a Little: "He saved us by the Holy Spirit."

Meaning

We can never please God with our own, good works. Only through Jesus' perfect life offered up in the place of sinners can we be saved. And what a salvation it is! God, Himself, sends His Holy Spirit to work in the hearts of His people. He gives them the gift of faith. He helps them turn away from their sins. He makes them clean of their sins and all new on the inside. This is how we, too, can become God's people--His heirs; that is, His children who will receive eternal life and live with Him forever.

Some Questions for You

1. Can we ever please God with our own, good works? *No.*
2. Whose perfect life can pay for our sins and save us? *Jesus'!*
3. Who does God send to work in our hearts? *The Holy Spirit.*
4. What does the Holy Spirit do inside of the hearts of people? *He helps them turn away from their sins and trust in Jesus as their Savior. He makes their hearts clean, as if they had never sinned. He lives inside of them and makes them God's people forever.*
5. Can we ask the Holy Spirit to work in our heart? *Yes, we can! God loves to answer this prayer!*

Let's Pray!

- A** God, we praise You for being the Changer of the hearts of sinful people, like us.
- C** God, we confess that we are all sinners. We have hard hearts that are slow to believe, love, and obey You. We need Jesus to save us!
- T** Thank You for sending Your Holy Spirit to work in the hearts of people like us, so we can know You, love You, and live for You. You give us what we need but could never get on our own.
- S** God, send the Holy Spirit to work in our hearts. Give us faith as we hear Your Word, the Bible. Help us to turn away from our sins and trust in Jesus as our Savior. Make us new creations! Give us the new birth! We want to know You and live for You! In Jesus' name we pray, Amen.

Let's Sing Our Bible Verse!

He Saved Us: Titus 3:5-7 from *Deep Down Detectives* ESV Songs 11, track 21

He saved us, he saved us,
By regeneration
And renewal of the Spirit.
He saved us, he saved us,
By the Holy Spirit.

The Holy Spirit whom he poured out,
On us richly,
Through Jesus Christ our Lord,
The Holy Spirit whom he poured out,
On us, through Jesus Christ.
Titus Three, verses five through seven.

Go to the *Deep Down Detectives* Parent Resources for Unit 11 to get the Bible story and many more resources and songs for this unit at praisefactory.org

Which four of these clues belong in our story? Which two do not? Put an X in the boxes of the four that belong.

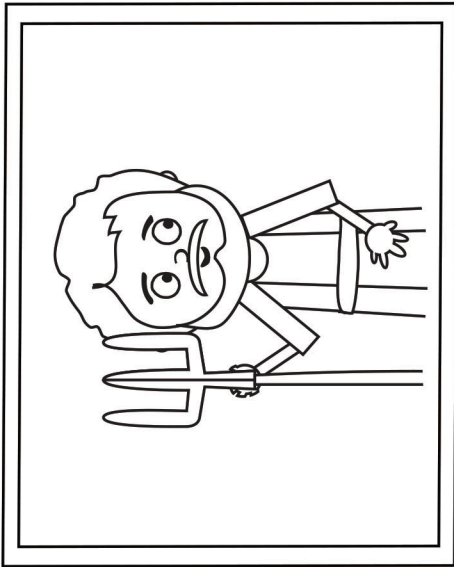

A Farmer

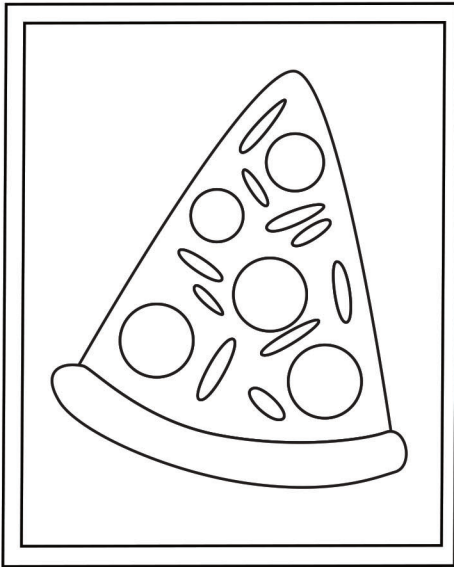

A Pizza

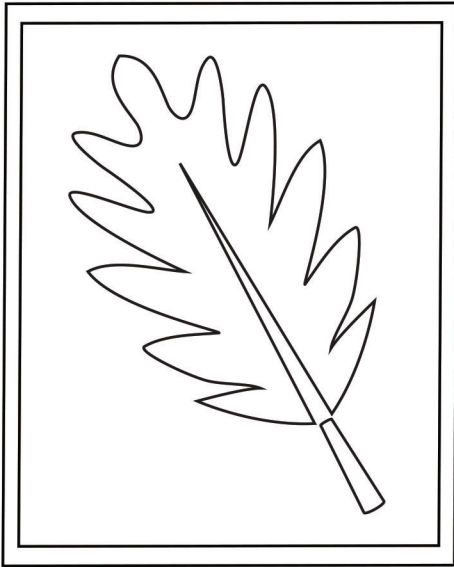

A Leaf

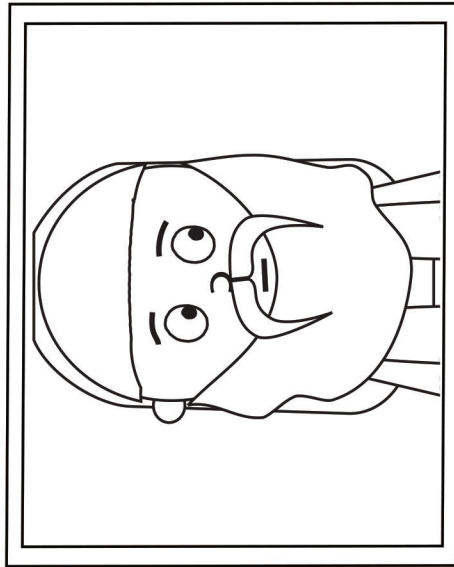

An Important Man

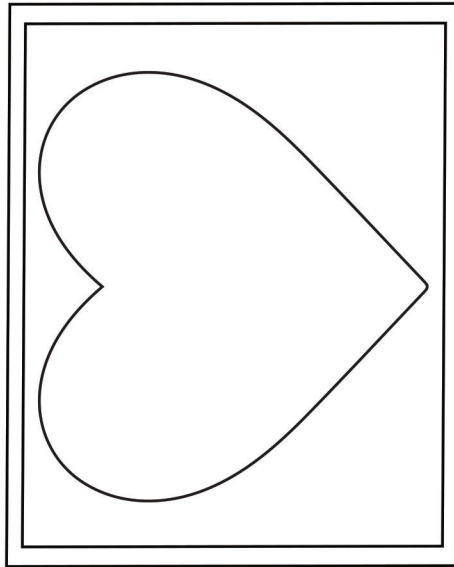

A Heart

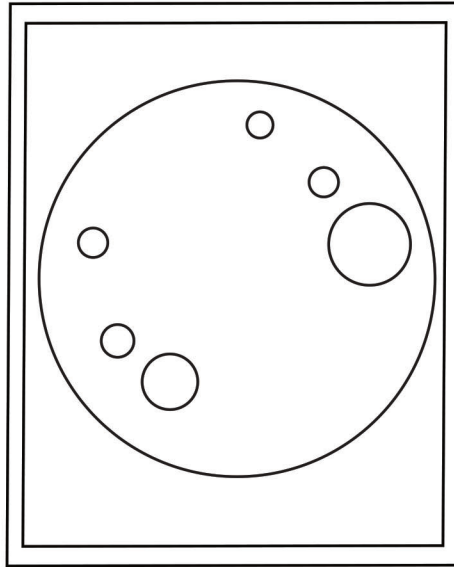

The Moon

Answer: The farmer, important city person, a heart, and the moon belong. The pizza and the leaf do not.

Deep Down Detective Devotion: Unit 11, Bible Truth 3, Lesson 3



Big Question 11: How Can We Be Saved?

Answer: It Is God's Free Gift... When the Holy Spirit Works in Our Hearts!

Bible Truth 3 Meaning

All of us are sinners. We would rather do things our own way rather than obey God. We have hearts that are dead and empty of love for Him and His good ways. We would never choose to love God on our own. But guess what God does for His people? He treats them so much better than they deserve! He sends His Holy Spirit to work in their hearts. When they hear God's Word, He helps them know they are sinners. He helps them want to stop disobeying God and trust in Jesus as their Savior. He makes their hearts alive to God. Now, they know God and want to obey and love Him. We can be God's people, too! We can ask God to send the Holy Spirit to work in our hearts. He can help us to ask God to forgive our sins, trust Jesus as our Savior, and live for Him. Then we can know God in our hearts, now; and when we die, we will go to live perfectly happily with Him forever.

How do I know this is true? The Bible tells me so!

"...He saved us, not because of works done by us in righteousness, but according to his own mercy, by the washing of regeneration and renewal of the Holy Spirit." --Titus 3:5-7, ESV

Some Questions for You

1. What were the country people and the city people think about Jesus? *They were amazed at the things He told them about God and the great things He did by God's power.*
2. Who was working in the hearts of people as Jesus taught them about God? *The Holy Spirit.*
3. What was the Holy Spirit doing in people's hearts? *He was giving them faith to believe in Jesus and to want to turn away from disobeying God and trust in Jesus as their Savior.*
4. Who was Nicodemus? *He was an important teacher of God's Word who lived in the big city of Jerusalem.*
5. What was something new that Jesus taught Nicodemus? *That no one can do enough good things to please God. We are all sinners. We all need God's Holy Spirit to come into our hearts and clean them of sin and give us faith to believe in Jesus.*
6. What is something we can ask God the Holy Spirit to do in our hearts today? *To work in our hearts, helping us to turn away from disobeying God and trust in Jesus as our Savior. Then, our hearts will be clean of sin and we will be born again as God's dearly-loved people. Ask Him to help you. He loves to answer this prayer!*

Let's Pray!

- A** God, we praise You for being the Changer of the hearts of sinful people, like us.
- C** God, we confess that we are all sinners. We have hard hearts that are slow to believe, love, and obey You. We need Jesus to save us!
- T** Thank You for sending Your Holy Spirit to work in the hearts of people like us, so we can know You, love You, and live for You. You give us what we need but could never get on our own.
- S** God, send the Holy Spirit to work in our hearts. Give us faith as we hear Your Word, the Bible. Help us to turn away from our sins and trust in Jesus as our Savior. Make us new creations! Give us the new birth! We want to know You and live for You! In Jesus' name we pray, Amen.

Let's Praise God Right Now!

Big Question 11 Hymn: Grace that Is Greater than All Our Sin from *Deep Down Detectives* ESV Songs 11, track 15

Verse 1

Grace, grace, God's grace,
Grace that will pardon and cleanse within;
Grace, grace, God's grace,
Grace that is greater than all our sin.

Words: Julie H. Johnston Music: Daniel B. Towner

Go to the *Deep Down Detectives* Parent Resources for Unit 11 to get the Bible story and many more resources and songs for this unit at praisefactory.org

Big Question 11 Praise Song: Blessed Be the Name from *Deep Down Detectives* ESV Songs 11, track 16

All praise to Him who reigns above	Blessed be the name,
In majesty supreme.	Blessed be the name,
Who gave His Son for man to die,	Blessed be the name of the Lord;
That He might man redeem!	Blessed be the name,
	Blessed be the name,
	Blessed be the name of the Lord.

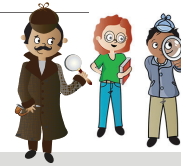
Bible Story for Big Question 11, Bible Truth 3**The Case of the Surprising, Second Birthday***John 3*

Dear Parents,

Big Question #11 is: "How Can We Be Saved?" Your child is learning that "It Is God's Free Gift...When the Holy Spirit Works in Our Hearts!"

Here's a copy of the Bible story they are learning along with the "Listening Assignment" for each lesson. These assignments provide a different teaching emphasis for each lesson, helping the children dig deeper into each Bible truth. They match up with your child's take home for each lesson. We hope that these resources help your family to dig down deeper into the truths of God's Word!" Happy digging!

•many more resources for this Big Question can be found online at www.praisefactory.org•

Listening Assignments

"Hey, Kids! Detective Dan, here. Listen carefully to the story and help me answer these questions:

Detective Dan's Lesson #1 Listening Assignment:

I need to know:

- 1. What special kind of second birthday Did Jesus promised to all who trust in him as her Savior?**
- 2. To Who did Jesus tell about this birthday? What did they find so surprising about it?**

Detective Dan's Lesson #2 Listening Assignment:**Our Bible Verse is Titus 3:5-7:**

"...He saved us, not because of works done by us in righteousness, but according to his own mercy, by the washing of regeneration and renewal of the Holy Spirit."

I need to know:

- 1. What kind of special, second birthday does God give to each of His people?**
- 2. Who does God send to work in their hearts and give them this special, second birthday?**

Detective Dan's Lesson #3 Listening Assignment:I found six clues, but two of them are **NOT** in the story.

They are: a farmer, a pizza, a leaf, an important city person, a heart, and the moon.

Hold each of them up for the children to see as you identify them.

I need to know:

- 1. Which four belong in the story and which two don't?**
- 2. Who did the Holy Spirit work inside of as they listened to Jesus preach? What special birthday did God give them when he worked?**

Read the assignment questions, THEN SAY,

"Ok, Deep Down Detectives! Put on your best listening ears and see if you can hear the answers to Detective Dan's questions. When I finish telling the story, we will see if we can answer all the questions."

Read the Bible Truth story, answer questions, present the gospel and lead in prayer.

Answers to questions; the gospel; and, ACTS prayer are included with the story text.

The Case of the Surprising, Second Birthday*John 3**Story with lines separating paragraphs (text in bold, optional interaction cues in italics)*

To the country, to the cities, went Jesus and His disciples. And everywhere they went, people came. Jesus taught them about God and did amazing things by God's power.

What kind of country people came to Jesus? Well, there were plain, country people like shepherds, fishermen, and farmers. And there were important country people, like the teachers of God's Word and government workers. Poor people, rich people. Good people, bad people. Sick people, healthy people. Fathers, mothers, and children. They all came to Jesus to hear Him teach about God and do amazing things.

And amazed they certainly were, by what they heard and saw. "This Jesus is not like any other teacher. What amazing things He says about God. What amazing things He does. He even heals sick people with just His words. Let's hear more. Let's see more," they exclaimed.

Soon, big crowds of country people followed Jesus, listening to Him teach about God and watching the amazing things He did by God's power.

But you know, Jesus wasn't the only one doing amazing things by God's great power. God, the Holy Spirit, was doing some amazing things, too.

For as some of those country people listened to Jesus talk and watched the amazing things He did, God, the Holy Spirit, was at work in their hearts, changing them.

What kind of changes do you think the Holy Spirit was doing in them?

The Holy Spirit helped them turn away from their sins and trust in Jesus as their Savior. Yes, by His Holy Spirit, God was giving these people the best gift of all: the gift of being saved by faith in Jesus.

This wonderful gift meant God forgave their sins and made them His people. They could know and love God in their hearts. And one day, when they died, they would go live with Him, face-to-face forever. What a wonderful thing the Holy Spirit was doing as those country people listened to Jesus!

But God didn't just care about country people. He cared about city people, too. So, Jesus and His disciples left the country and went to the great city of Jerusalem. And what did Jesus do when He went there?

Can you guess?

Jesus taught them about God and did amazing things by God's great power, just like He had in the country.

All sorts of city people came to Jesus. Plain, city people, like the people who sold things in the markets, came. Important city people, like the Pharisees (the teachers of God's Word) and government workers, came, too. Poor people, rich people. Good people, bad people. Sick people, healthy people. Fathers, mothers, and children. They all came to Jesus to hear Him teach about God and do amazing things.

Story with lines separating paragraphs (text in bold, optional interaction cues in italics)

And amazed they certainly were, by what they heard and saw. "This Jesus is not like any other teacher. What amazing things He says about God. What amazing things He does. He even heals sick people with just His words. Let's go hear more. Let's go see more," they exclaimed.

Soon, big crowds of city people followed Jesus, listening to Him teach about God and watching the amazing things He did by God's power.

But you know, Jesus wasn't the only one doing amazing things by God's great power in the big city of Jerusalem. Can you guess who else was at work?

Can you guess who?

It was God, the Holy Spirit. He had done amazing things in the country people; and now, He was doing amazing things in the city people, too. For as some of those city people listened to Jesus talk and watched the amazing things He did, God, the Holy Spirit, worked in their hearts, changing them. He helped them turn away from their sins and trust in Jesus as their Savior.

Yes, by His Holy Spirit, God was giving these people the best gift of all: the gift of being saved by faith in Jesus.

This wonderful gift meant God forgave their sins and made them His people. They could know and love God in their hearts. And one day, when they died, they would go live with Him, face-to-face forever. What a wonderful thing the Holy Spirit was doing as those city people listened to Jesus!

Now, among the city people who came to Jesus, was a man named Nicodemus. Nicodemus was NOT a plain, city person. He was one of the most important people in both city AND country!

Can you guess what Nicodemus did that would have made him so important?

Nicodemus was one of the head teachers of God's Word. He had spent years and years learning God's Word, then years and years teaching it to others. People looked to Nicodemus to teach them how to live to please God and obey His laws.

But when Jesus came to Jerusalem, Nicodemus just shut his mouth and listened and watched. He could see that Jesus was a teacher unlike any other. A teacher especially sent by God. When Nicodemus was around Jesus, he didn't feel like a teacher anymore. He felt like a learner. "No one could do the things Jesus does if God had not sent Him," Nicodemus thought.

What amazed Nicodemus the most was what was happening in the city people who came to Jesus. Nicodemus had taught the people to work hard to obey God's good laws. These good works were how to please God, he taught them. People listened to Nicodemus when he taught, but they rarely ever changed.

But when Jesus taught, people were turning away from the bad things they had been doing! They were putting their trust in God! Jesus was teaching, and people were CHANGING!

Story with lines separating paragraphs (text in bold, optional interaction cues in italics)

What was going on? What was changing these people? Nicodemus wanted to know. He decided he would go to find Jesus and talk to Him, all by himself. So one night, Nicodemus made his way down the dark streets of Jerusalem to the place where Jesus stayed.

That night as they talked, Jesus answered Nicodemus' questions. Nicodemus was a good Pharisee. He taught the people that only by keeping all of God's good laws could they be God's people and be a part of God's kingdom. But Nicodemus had it wrong. Now, Jesus would teach the teacher.

"No one can become one of God's people and part of His kingdom unless they are born again," Jesus told him.

Nicodemus listened to Jesus' words. This time, he wasn't just amazed. He was confused!

Can you guess what confused him?

"Born again? How can this be, Jesus? I'm a full-grown man. Do I have to be born like a baby from a mother again? I don't understand," Nicodemus told Jesus.

"This is a new birth in your heart, not your body. Only God's Holy Spirit working in your heart can make you one of God's people," Jesus explained. "The Holy Spirit cleans a heart of sin, just like water cleans away dirt. He helps people repent. That is, He helps them not want to disobey God anymore. He helps them love God and trust in Me as their Savior," Jesus told Nicodemus. "And when the Holy Spirit works, He makes such a big change in your heart you become a new person on the inside, like being born again," Jesus said.

"How can this be?" Nicodemus asked, still trying to understand.

"Nicodemus, you are one of the best teachers of God's Word, yet you don't understand?" Jesus replied. "This why God has sent Me, His Son, from heaven. Yes, God loved the world so much that He sent Me to be the Savior. Whoever believes in Me won't be punished by God for their sins. They will have eternal life," Jesus said. "I will be lifted up on the cross and will pay for their sins, Myself. They will be God's people. They will live with God in His Kingdom forever," Jesus explained.

Nicodemus had much to think about that night as he went home. Jesus had taught him so much about God. New things he had never understood before. Jesus is God's Son, the Savior. The Holy Spirit works inside people to help them believe and make them brand-new people. God's people. What big ideas!

Did the Holy Spirit work in Nicodemus' heart as he thought about these things? It seems that He did. Who was it who helped take down Jesus' body from the cross when He died for the sins of God's people? It was Nicodemus! And who was it who took Jesus' body and buried it in a tomb? It was Nicodemus! Some say, Jesus' enemies made Nicodemus stop being a head teacher of God's Word because he believed in Jesus. The Bible doesn't tell us that part of Nicodemus' story.

But something I DO know for sure, is that we can ask God's Holy Spirit to work in our hearts right NOW! He can help us to turn away from disobeying God and to trust in Jesus as our own Savior. Yes, God offers to give even you and me the wonderful, free gift of salvation through Jesus. This is how we can become God's people and enjoy Him forever. Ask God to work in your heart. He loves to answer this prayer!

Cracking the Case: (story wrap-up for Listening Assignments)

It's time to see how we did with our Listening Assignment.

Detective Dan's Lesson 1 Listening Assignment:

1. What special kind of second birthday did Jesus promise to all who trust in him as their Savior? To be a changed person, forgiven of their sins, and one of God's people forever.

2. To whom did Jesus tell about this birthday? What did he find so surprising about it? To Nicodemus. He didn't understand that the Holy Spirit is the One who works inside us and changes our hearts. He is the One who helps us repent and believe, so we can become God's people.

For You and Me:

That special, second birthday wasn't just for important people like Nicodemus. It's for anyone who turns away from their sins and trusts in Jesus as their Savior. Ask the Holy Spirit to work in your heart and help you. He loves to answer these prayers!

**Detective Dan's Lesson 2 Listening Assignment:
Our Bible Verse is Titus 3:5, ESV:**

"... He saved us, not because of righteous things we had done, but because of his mercy. He saved us through the washing of rebirth and renewal by the Holy Spirit."

I need to find out:

1. What kind of special, second birthday does God give to each of His people? To be made a new person inside their heart. God forgives their sins and helps them trust in Jesus as their Savior.

2. Who does God send to work in their hearts and give them this special, second birthday? The Holy Spirit.

For You and Me:

That special, second birthday that God gave to His people long ago is something He still gives to people today. How? When they turn away from their sins and trust in Jesus as their Savior. Ask the Holy Spirit to come and work in your heart and help you do this. He loves to answer this prayer!

Detective Dan's Lesson 3 Listening Assignment:

Our six clues were: a farmer, a pizza, a leaf, an important city person, a heart, and the moon.

1. Which four belong in our story?

The farmer, the important city person, the heart and the moon belong.

2. Who did the Holy Spirit work inside of as they listened to Jesus preach? What special birthday did God give them when he worked? He worked inside of many country and city people. The Holy Spirit helped them turn away from their sins and trust in Jesus as their Savior. He changed their hearts so they would become God's people. This is the special, second birth of salvation through Jesus.

For You and Me:

The Holy Spirit work in the hearts of many as they listen to Jesus preach from God's Word long ago. And He still works in hearts today as we listen to God's Word. Ask Him to work in your heart. Ask Him to help you to turn away from your sins and trust in Jesus as your Savior.

The Gospel (story wrap-up if NOT using Listening Assignments)**Our Bible Truth is:****How Can We Be Saved?****It Is God's Free Gift...****When the Holy Spirit Works in Our Hearts!**

How can we be saved? It is God's free gift... when the Holy Spirit works in our hearts. All of us are sinners. We would rather do things our own ways rather than obey God. We have hearts that are dead and empty of love for Him and His good ways! We would never choose to love God on our own. We deserve God's punishment, but He is full of mercy! He sent His Son, Jesus, to be our Savior. Jesus lived a perfect life. Then on the cross, He suffered and died, giving His perfect life as the full payment for the sins of God's people. On the third day, Jesus rose from the dead. He had really beaten sin and death for them! We can become God's people, too, when we turn away from our sins and trust in Jesus as our Savior. God's Holy Spirit can work in our hearts, helping us to do this. And if we do, the Holy Spirit will go on working in our hearts the rest of our lives, helping us know God, love Him, and live for Him. Then one day, we will go to live with God forever. Ask Him to help you! He loves to do this!

Close in prayer. <?xml version="1.0" encoding="UTF-

Closing ACTS Prayer

- A** God, we praise You for being the Changer of the hearts of sinful people, like us.
- C** God, we confess that we are all sinners. We have hard hearts that are slow to believe, love, and obey You. We need Jesus to save us!
- T** Thank You for sending Your Holy Spirit to work in the hearts of people like us, so we can know You, love You, and live for You. You give us what we need but could never get on our own.
- S** God, send the Holy Spirit to work in our hearts. Give us faith as we hear Your Word, the Bible. Help us to turn away from our sins and trust in Jesus as our Savior. Make us new creations! Give us the new birth! We want to know You and live for You!

In Jesus' name we pray, Amen.

Big Question 11, Bible Truth 3 Overview: Key Concepts**P.7****Unit 11: The God Who Saves****Unit Big Question (and Answer):** How Can We Be Saved? It Is God's Free Gift!**Unit Bible Verse:** "For the wages of sin is death, but the free gift of God is eternal life in Christ Jesus our Lord."
--- Romans 6:23, ESV**Bible Truth 3 Concept: It Is God's Free Gift... When the Holy Spirit Works in Our Hearts!**

All of us are sinners. We would rather do things our own way rather than obey God. We have hearts that are dead and empty of love for Him and His good ways. We would never choose to love God on our own.

But guess what God does for His people? He treats them so much better than they deserve! He sends His Holy Spirit to work in their hearts. When they hear God's Word, He helps them know they are sinners. He helps them want to stop disobeying God and trust in Jesus as their Savior. He makes their hearts alive to God. Now, they know God and want to obey and love Him.

We can be God's people, too! We can ask God to send the Holy Spirit to work in our hearts. He can help us to ask God to forgive our sins, trust Jesus as our Savior, and live for Him. Then we can know God in our hearts, now; and when we die, we will go to live perfectly happily with Him forever.

Bible Truth 3 Bible Verse: Titus 3:5, ESV

"...He saved us, not because of works done by us in righteousness, but according to his own mercy, by the washing of regeneration and renewal of the Holy Spirit."

Learn a Little: "He saved us by the Holy Spirit."**Meaning**

We can never please God with our own, good works. Only through Jesus' perfect life offered up in the place of sinners can we be saved. And what a salvation it is! God, Himself, sends His Holy Spirit to work in the hearts of His people. He gives them the gift of faith. He helps them turn away from their sins. He makes them clean of their sins and all new on the inside. This is how we, too, can become God's people--His heirs; that is, His children who will receive eternal life and live with Him forever.

Bible Truth 3 ACTS Prayer

- A** God, we praise You for being the Changer of the hearts of sinful people, like us.
- C** God, we confess that we are all sinners. We have hard hearts that are slow to believe, love, and obey You. We need Jesus to save us!
- T** Thank You for sending Your Holy Spirit to work in the hearts of people like us, so we can know You, love You, and live for You. You give us what we need but could never get on our own.
- S** God, send the Holy Spirit to work in our hearts. Give us faith as we hear Your Word, the Bible. Help us to turn away from our sins and trust in Jesus as our Savior. Make us new creations! Give us the new birth! We want to know You and live for You! In Jesus' name we pray, Amen.

Bible Truth 3 Story**The Case of the Surprising, Second Birthday***John 3*

Big Question 11, Bible Truth 3 Overview: Key Concepts

p.8

Songs Used in Bible Truth 3

Big Q & A 11 Song

Big Question 11 Song: How Can I Be Saved?

Big Question 11 Bible Verse Song: The Free Gift of God Is Eternal Life Romans 6:23, ESV

Big Question 11 Hymn: Grace Greater than All Our Sin, refrain

Big Question 11 Praise Song: Blessed Be the Name

Bible Truth 3 Bible Verse Song: He Saved Us Titus 3:5-7, ESV

Extra Bible Truth 3 Bible Verse Song: I Will Give You a New Heart Ezekiel 36:26, ESV

listen to or download songs for free at <https://praisefactory.org>: Deep Down Detectives Music page

Go and Tell Bible Truth Concept Craft

Scrunchy, Glittery Hearts

Craft Description

The children will decorate a heart to remind them of how the Holy Spirit works in our hearts, that we might believe and be saved.

Materials

Manilla file folder, 1 per child

White paper or cardstock

Marker

Glue

Red sequins; or, red foil paper or tissue paper (cut into little squares)

Crayons or markers

Preparations

1. Cut the tissue paper into square or circle shapes about 1 ½" in diameter.

2. Copy Template #1 onto paper or write words & draw heart shape onto paper as shown.

3. Set out glue on paper plates (or glue sticks). Reserve glitter glue to use with children as they finish the first phase of their craft.

Introducing the Craft:

"Our Big Question is: "How Can We Be Saved? It Is God's Free Gift...When the Holy Spirit Works in Our Hearts!" That's something very good to know. But many people don't know that. So, do you know what God wants us to do? He wants us to go and tell others this very important news. So today we are going to make something we can show and tell them, too. Here's what it looks like... (Hold up example of craft)

Directions

1. Show children your finished craft, reading the words to them.

2. Show the children how to scrunch up pieces of tissue paper, dab them in the glue and stick them on the heart shape.

3. When a child is finished filling in their heart with tissue, help them either squeeze little blobs of the glitter glue in between the tissue pieces or around the outside of the heart

4. Make sure to write each child's name on their craft.

5. If you have time, practice saying the words on the cards with the children.

Discussion

This is an especially good time to re-read the key concepts and discuss them. See the Deep Down Discussion Sheet for possible questions to talk about.

Craft Wrap-Up:

"At the end of our time together today, you get to take home your Go and Tell crafts. And what are you going to do with them? Show and tell someone the important news you've learned today: "How Can We Be Saved? It Is God's Free Gift... When the Holy Spirit Works in Our Hearts!"

How Can I Be Saved? It is God's Free Gift...

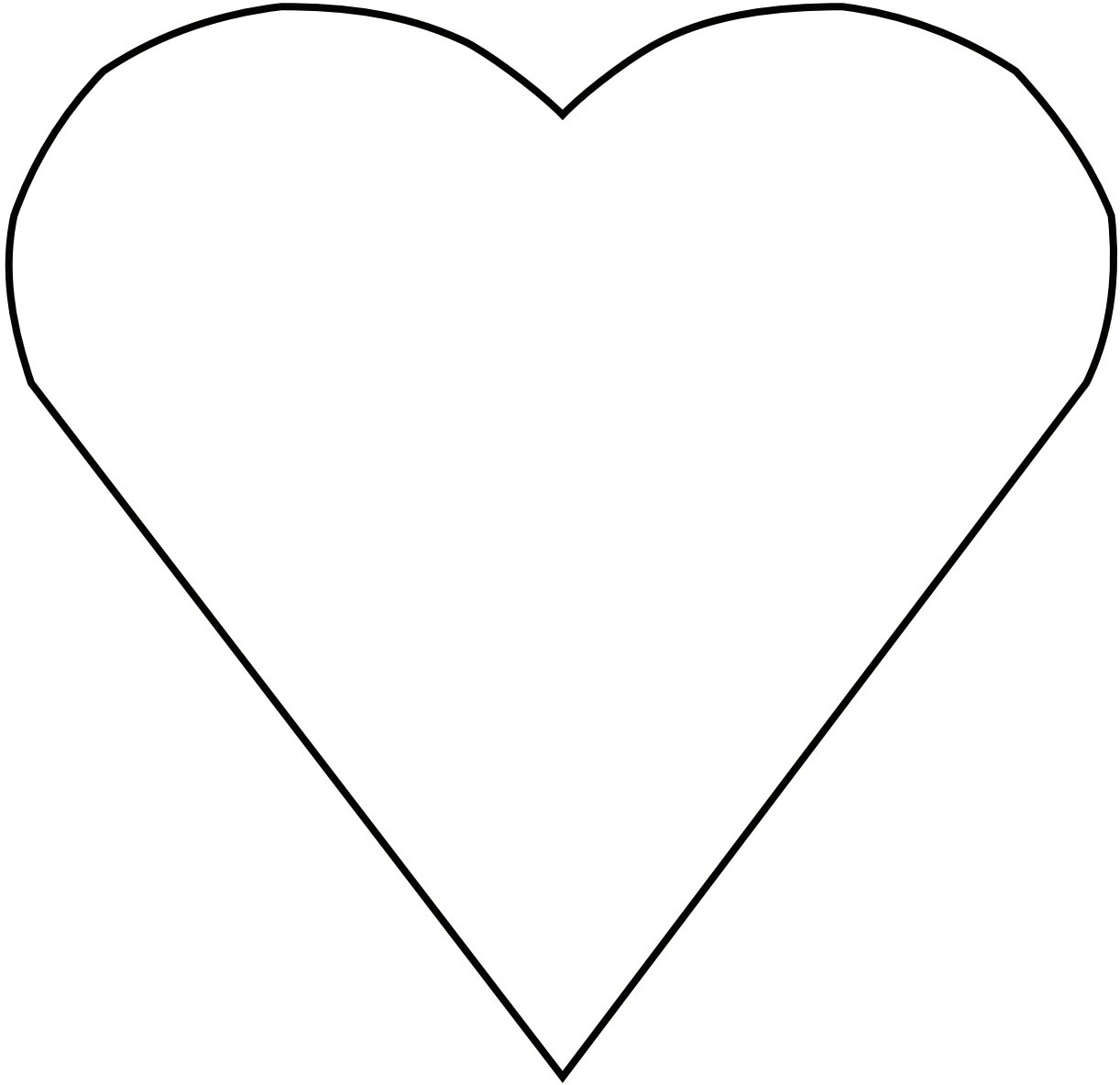

**when the Holy Spirit works
in our hearts**

He saved us, not because of works done by us in righteousness, but according to his own mercy, by the washing of regeneration and renewal of the Holy Spirit." --Titus 3:5-7, ESV

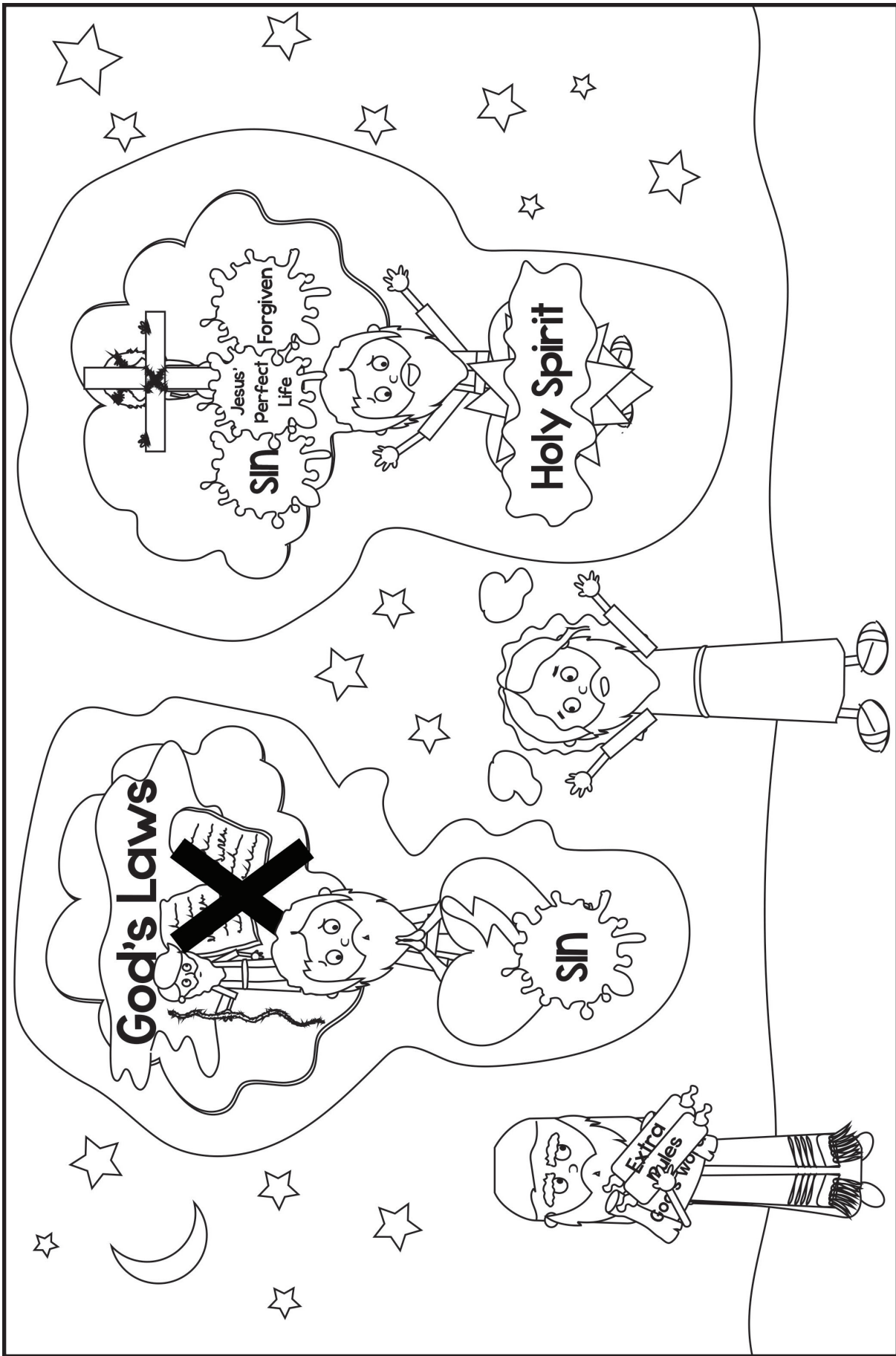

How Can We Be Saved? It is God's Free Gift....When the Holy Spirit Works in Our Hearts! Did the Holy Spirit work in Nicodemus' heart as he thought about all that Jesus told him? It seems that he did. Who was it who helped take down Jesus' body from the cross when He died for the sins of God's people? It was Nicodemus! And who was it who took Jesus' body and buried it in a tomb? It was Nicodemus! Some say, Jesus' enemies made Nicodemus stop being a head teacher of God's Word because he believed in Jesus. The Bible doesn't tell us that part of Nicodemus' story. The Bible doesn't tell us that part of Nicodemus' story. But something I DO know for sure, is that we can ask God's Holy Spirit to work in our hearts right NOW! He can help us to turn away from disobeying God and to trust in Jesus as our own Savior. Yes, even to you and me, God offers to give us the wonderful free gift of salvation--of life with God forever, through Jesus. Let's ask God to work in our hearts! Let's ask Him to give us this gift!

The Case of the Surprising Second Birthday Jigsaw Puzzle Page John 3

Make copies of picture and cut out into an appropriate number of pieces for your children.
Or, you can print out color versions of this puzzle by downloading it from praisefactory.org.

How Can We Be Saved? It Is God's Free Gift....When the Holy Spirit Works in Our Hearts! Did the Holy Spirit work in Nicodemus' heart as he thought about all that Jesus told him? It seems that he did. Who was it who helped take down Jesus' body from the cross when He died for the sins of God's people? It was Nicodemus! And who was it who took Jesus' body and buried it in a tomb? It was Nicodemus! Some say, Jesus' enemies made Nicodemus stop being a head teacher of God's Word because he believed in Jesus. The Bible doesn't tell us that part of Nicodemus' story. The Bible doesn't tell us that part of Nicodemus' story. But something I DO know for sure, is that we can ask God's Holy Spirit to work in our hearts right NOW! He can help us to turn away from disobeying God and to trust in Jesus as our own Savior. Yes, even to you and me, God offers to give us the wonderful free gift of salvation--of life with God forever, through Jesus. Let's ask God to work in our hearts! Let's ask Him to give us this gift!

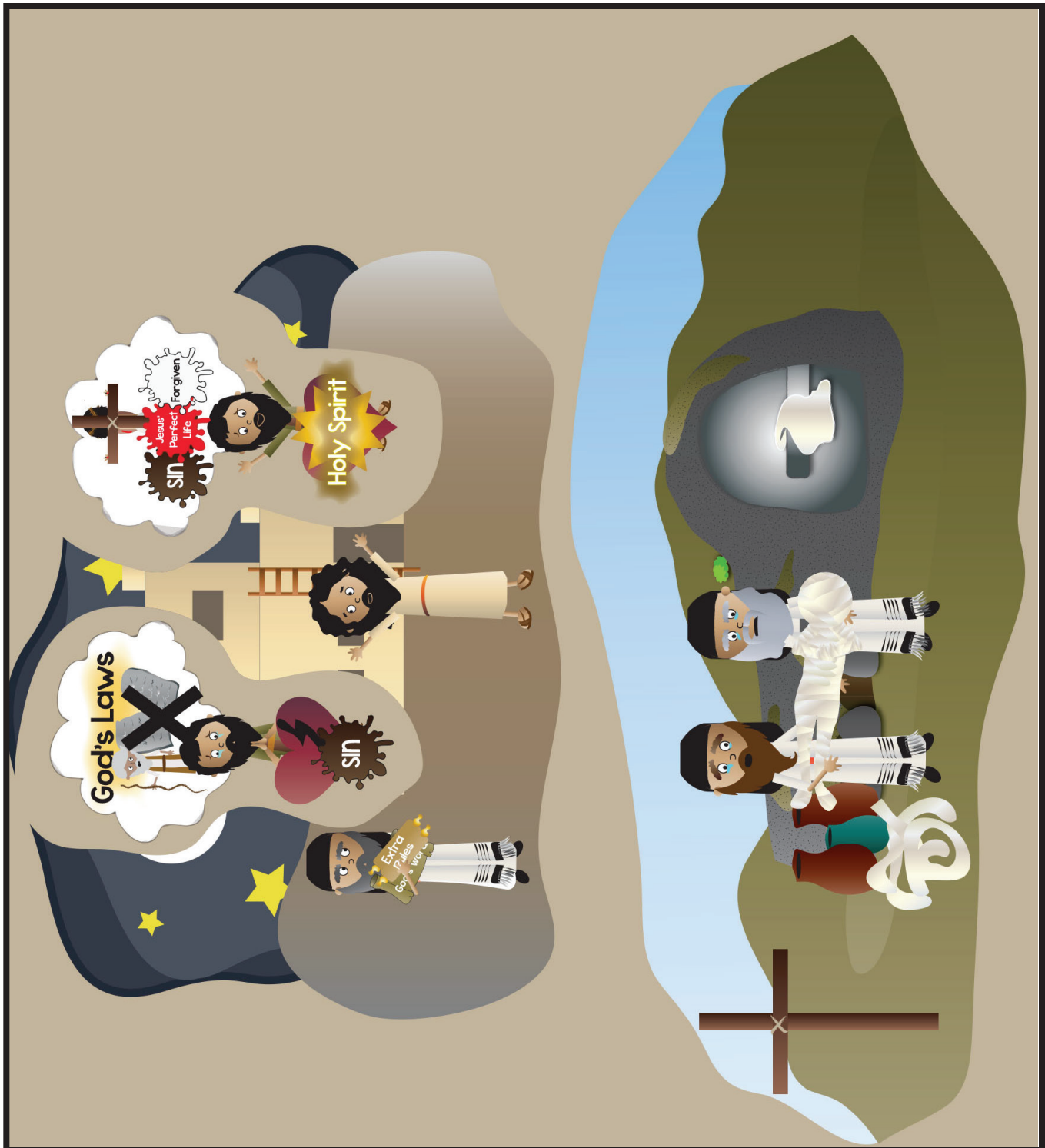

DEEP DOWN DETECTIVES

Curriculum Resources



**Appendix D:
Just for Fun
Activities**

Just-For-Fun Activities

The following are activities that you can incorporate into your free play time. While the activities, themselves, are just-for-fun, you can make them rich times of relationship building, and even use it as an opportunity to discuss what is being taught during Circle Time. Don't over do it, but you can use the Deep Down Detectives Discussion Sheet for question ideas.

Gluing and Sticking

Just for Fun Arts and Crafts

Directions

Teacher cuts out or draws a basic shape or shapes related to concept or story on cardstock or construction paper for children to stick stickers on or glue fabric or paper scraps (tissue, gift wrap paper, construction paper, etc), beans, popcorn, buttons, cotton balls, foam shapes etc. onto. Use glue sticks rather than craft glue for these crafts. Cut fabric/paper scraps fairly large—about 1" or so.

Print-Making

Just for Fun Arts and Crafts

Directions

Children will make designs on a plain piece of construction paper or one with a simple shape drawn on it, using tempera paint (with a little dish soap added to it to make clean up easier) and any number of objects. Objects suggested in this curriculum: marbles, duplos, sponge shapes, empty thread spools, blocks with rick-rack glue-gunned to the bottom of them, cars and trucks, bubble wrap and cork.

Necklaces

Just for Fun Arts and Crafts

Directions

These are made with hollow pasta shapes and hole-punched shapes related to the story/concept. Children can string these onto a piece of yarn or string and have you tie the ends together when they are done.

Coloring (Really Scribbling)

Just for Fun Arts and Crafts

Directions

Children will use crayons or washable markers to draw on construction paper. If desired, the teacher can draw a picture or shapes related to the story on the paper for children to scribble on.

Puzzles

Just for Fun Arts and Crafts

Directions

A simple picture related to the story or concept is printed out onto cardstock and cut into a puzzle of 4 to 10 pieces. This can be done by enlarging one or a number of the people/objects from the story, in a Word, Power-point or other program to the desired size, then printing out onto cardstock. Children can "color" in the picture, then you can cut it out for them into as many pieces as is fitting for the child.

Craft Dough

Just for Fun Arts and Crafts

Directions

Provide purchased or homemade play dough (recipe provided) along with various “tools” such as plastic knives (without teeth), small jar lids, keys, garlic presses, little rolling pins, plastic cookie cutters, etc.

Homemade Play Dough Recipe

2 cups flour
1 cup salt
4 tsp cream of tartar
2 tbsp oil
2 cups water

Combine the flour, salt and cream of tartar. Mix well. In a large pot, combine the oil and the water. Add food coloring, if desired. Add flour mixture to the pot, stirring as you add. Heat mixture over medium heat, stirring constantly. Continue to stir until mixture forms ball and pulls away from the sides of the pot. Remove ball and knead on plain surface (not floured) until the texture becomes like play-dough. Store dough in an airtight plastic container. Keeps about 3 months. Makes about 5 cups. Allow at least a ½ cup per child.

Sandpaper Shapes and Patterns

Just for Fun Arts and Crafts

Directions

Use a glue gun to glue full 8 ½” by 11” sheets of sandpaper to foam board or sturdy cardboard cut the same size. Give the children yarn pieces of various lengths, 4” to 12” long. Let them stick the yarn onto the sandpaper and make designs and pictures with them.

Dance Ribbons

Just for Fun Games

Supplies

3 4’ ribbons per child
1 plastic shower curtain ring per child
CD player
CD of music

Preparing the Activity

1. Tie three 4’ ribbons to a plastic shower curtain ring.

Directions

1. Give them to the children to run around with. Have music for them to dance to as they twirl their ribbons. If desired, you could have them sing the Big Question/Bible verse song.

Match the Shape with Objects

Just for Fun Games

Supplies

Common objects such as keys, cookie cutters, spoons, unsharpened pencils, etc.

Cardstock

Permanent marker

Shoe box

Preparing the Activity

1. Trace around common objects such as keys, cookie cutters, spoons, unsharpened pencils, etc., each on a separate piece of cardstock.

2. Put these and the objects in a shoe box.

Directions

Have the children take out the cardstock outlines and the shapes and match them up.

Match the Shape with Blocks

Just for Fun Games

Supplies

Shoe box

Different shape blocks

Duct tape

Preparing the Game

1. Cut the outline of different blocks from a child's building block set in the top of a sturdy shoe box.

2. Use duct tape to tape down one long side, making a hinge for the lid.

Directions

1. Have the children put the right shape block into the box through the hole of the same shape.

Ball 'n' Tube

Just for Fun Games

Supplies

Have the children match the block shapes and insert them into the shoe box.

Materials

4-6' length of PVC pipe with a 2"-3" diameter opening, found very inexpensively at home improvement stores

Various sizes of balls that will fit through the diameter of the PVC pipe

Playing the Game

1. Have the children take turns putting the ball down one end and watching it roll out the other.

Bowling

Just for Fun Games

Supplies

6 or so empty 2-liter soda bottles
A soft, foam ball
Optional: sand or beans, packing/duct tape

Preparing the Game

If desired, put sand or beans in all/some of the bottles. Seal with tape.

Directions

Line up empty 2 liter soda bottles and have the children try to knock them down by rolling a ball into them.

Color Sort

Just for Fun Games

Supplies

Various single colored objects, such as pom-poms, foam shapes, beads, etc. (Be careful to choose objects of a non-swallowable size)
1 Large container that fits all the objects in it at once
Smaller containers, one per color
Construction paper or markers

Preparing the Activity

1. Put all the objects in the large container. Mix up.
2. Put a piece of construction paper/paper colored with marker on the outside of each of the small containers that matches the color object to go in it.

Directions

Have the children separate out all the colored items into their proper container.

Pattern Post Office

Just for Fun Games

Supplies

Various scraps of gift wrap paper or other colorful paper
Glue stick
Cardstock or cereal box
Shoe Box

Preparing the Activity

1. Cut out envelope-sized pieces of gift wrap paper (or scrap booking paper) and glue them onto cardstock of the same size.
2. Have a shoe box with a letter slit cut in the top for each of the different paper types.
3. Glue a piece of the designated gift wrap paper for each particular box on top of the box.

Directions

Have the children sort through the "mail" and put them in their right mail slot.

More Ideas for Activity Centers

Dress-up Clothes
Hats and Crowns
Simple Wooden Puzzles
Duplos
Blocks and Cardboard bricks
Peg Sets*
Magnet Sets (especially "Tall Stacks")*
(Large) Beads and Threading Laces
Small plastic people, animals, and vehicles*
Lacing cards
Housekeeping sets
Doctor's and nurse's sets
Tool sets
Simple Matching games
Dolls
Train sets
Sand or Rice Center with containers
Magnifying glasses and objects*
Shape and Color Sorters
Ring Stackers
Pull toys
Hammer and Peg sets
Tap a Tune pianos
Balls, everything from nerf balls to beach balls*

Great Idea Books

for homemade activity centers

The Wiggle & Giggle Busy Book: 365 Fun, Physical Activities for Your Toddler and Preschooler, Trish Kuffner and Megan McGinnis
The Toddler's Busy Book, Trish Kuffner
Arts and Crafts Busy Book
The First Three Years of Life, Burton L. White
Creative Resources for Infants and Toddlers, Judy Herr and Terri Swim

Websites

Just for Fun Games for ordering activity centers activities and materials

christianbook.com
amazon.com
toysrus.com
growingtreetoys.com
orientaltrading.com

DEEP DOWN DETECTIVES

Curriculum Resources



**Appendix E:
Curriculum Resources
to Make or Buy**

Big Question Box/Briefcase

What You Want

The Big Question Briefcase is a briefcase or other container with these characteristics:

- Ideally, this should be around 17" x 12", but needs to be at least big enough to fit a 8 ½" x 11" sheets of paper inside it.
- Have various pockets to put these sheets in
- Is attractive or curious looking to preschoolers
- Not necessary, but extremely fun, if it has a combination lock

Finding a Briefcase:

You can certainly buy one new, but you always may find a used one at a thrift shop. Or, someone may have one they want to donate. We use one that stores valuables in it and is the 17" x 12" size. Very durable and has the lock feature that the kids love.

You also can move away from the briefcase idea and use a little trunk or other box for your substitute briefcase. Just change the name to the Big Question Box, if you use a box instead. A boot box or the cardboard box that 10 reams of copy paper comes in is a great size, if you are using a box.

If you use a box, but want a lock-like feature, that's easy to do. Simply cut "straps" out of felt or vinyl and glue in place to the top and bottom sides of the box on one side, with the top strap overlapping the bottom straps. Add velcro to the top and bottom pieces so that they meet and fasten. Make back "hinges" for the box with the felt/vinyl straps, too. Or, you can simply add a belt around the box that has to be unfastened before the box can be opened.

Here are some suggestions for decorating a box or even the outside of your briefcase to make it appealing.

Supplies

Your box/briefcase
Plain white contact paper or white cardstock
Colorful wrapping paper
Glitter glue
Markers
Sequins, fake jewels, buttons, rick rack, etc.
Other decorating supplies
Stickers
Glue
Clear packing tape

Directions

1. If you are using a box that has wording on it, you will first need to make plain surfaces for decorating and a hinge for the lid. Stick the white contact paper or white cardstock to each side of the box. On the other hand, you can also use colorful wrapping paper. Then, make a lid by sticking the clear packing tape along one long side of the box, attaching the lid to the box.

2. Use the craft decorating supplies to decorate the box. If desired, you can put a big question mark on top of the box, but remember that you are working with two and three year olds: the question mark symbol is not very meaningful to them yet.

Making a Flannelgraph Storyboard **for use in story-telling and in playing the story review games**

While you may decide to use sticky tac and stick your storyboard pictures to a white board, it is very easy to make a flannelgraph board. The advantage to the flannelgraph board is that the pictures stick very easily and there is no messing with the sticky-tac.

Supplies

Large Format Pictures Board: AT LEAST a 36" x 48" foamboard or corkboard (We actually use a far bigger canvas and attach it to the wall) A science project board with the two sides that fold out makes a good 36" x 48" board.
OR, Small Format Pictures Board: AT LEAST a 24" x 36" (to 36" x 48)" board
Large piece of neutral-colored felt to cover your board with extra to overlap over to the back, if desired.
Glue gun and glue sticks

Directions

1. Center felt on front side of board. Turn over. Secure in place with glue.

Making Durable Storyboard Pictures or Story Scenes **for use in story-telling and in playing the story review games**

Whether you purchase the Deep Down Detectives storyboard pictures from Amazon or print them off the website (included in the Deep Down Detectives Visual Aids book), you will want to find some way to make them more durable. They are used not only as a part of telling the story, but are integral in the story review games. Here's how we make ours durable enough to be used over and over again. **See note below for other simpler options for using these pictures.**

Supplies

Deep Down Detectives Visual Aids book (purchased or downloaded)
White cardstock or printer paper (if downloading pictures)
Sticky-back velcro, circles or cut pieces; or sticky tac putty
Laminator or Self-laminating sheets
Sturdy Sheet Protectors, preferably the "Secure Top" kind, like offered by Avery
Flannelgraph pictures for the Bible stories found at www.praisefactory.org with each unit's resources.

Directions

1. Purchase from Amazon or download and print out the storyboard figures.
2. Cut out flannelgraph figures.
3. Laminate the figures.

Special tip: When laminating the big background pictures that are two (and sometimes even three or four) pieces put together, leave a small gap between the two pieces before laminating together. This small space acts like a hinge and allows you to fold up pictures without hurting them into a manilla envelope that fits 8.5" x 11" sheets of paper along with all of the smaller, regular-sized storyboard pictures.

4. If using a flannelgraph board: Stick a piece of sticky backed velcro (ROUGH SIDE) onto the back of each figure. If using sticky tack and whiteboard: simply stick a small amount of sticky tack on the back of a picture when using it. Remove and store sticky tack in airtight container.

Note: Instead of using all of the pictures as separate flannelgraph pieces, you can choose to use only a few (helpful to have 10 for the story review game); you can clump them onto posterboard and make them into picture scenes; or, you can simply use the Storyboard Picture Guide as a single picture. At praisefactory.org, go to DDD Bits and Pieces for a 22" x 28" poster size jpg of this picture guide if you want to create a large version.

The Deep Down Detectives “Bible” Folder

This is a homemade folder that looks (kinda) like the cover of a Bible. You will use this to put the Bible verse, the Bible Story and storyboard pictures to help make the point that the truths you are teaching them come from the Bible.

Supplies

1 piece of 22" x 28" posterboard (white is fine. Green or brown is nice)

Glue

Stapler and staples or packing tape

The Bible Cover pictures (see online with resources for this unit or from the back of each Deep Down Detectives Visual Aids book.)

NOTE: The Bible Cover pictures included in the Deep Down Detectives Visual Aids books cannot be created larger than 8.5" x 11". That means that they will be under-sized for a Bible Folder of the dimensions you are making. However, you can go online to the Deep Down Detectives curriculum and there is a pdf of a bigger version of these covers that will actually fit the size of this Deep Down Detectives “Bible” Folder.

Directions

1. Lay out poster board with long side along the bottom.
2. Fold in 2" on each side.
3. Take packing tape and tape the folded in 2" flaps to the main section of the posterboard, all the way down.
3. Fold up 8 1/2" on the bottom of the poster board.
4. Use packing tape to tape this flap in place, all the way down.
5. Take scissors and snip through the tape where the flap is attached to the folder. This will give you a bit more room in the folder.
6. Fold the poster board in the middle to make the center fold.
7. Cut out the Bible Cover Pictures. If possible, laminate these. They will last longer.
- 8.. Glue the two cover pieces to the outside of the folder.

